

SHIPLINK[®]

LSHF CABLE

NEK TS 606 : 2016

Cable solutions and services
for safety and reliability in ship and offshore



CREATING VALUE UPSTREAM

To meet the needs of upstream development, Nexans implemented a program based on Four Pillars to create value for upstream oil & gas players. It provides the technology, quality and collaboration needed for future upstream growth:

Cable Performance

To increase operational safety on platforms, protect field assets, handle drilling muds, avoid operational downtime, allow drilling in arctic temperatures, protect against UV, and increase cable length between Variable Speed Drives and Motors:

- Fire-resistance performance exceeding IEC60331-1&2 and BS50200 / BS6387
- Mud-resistant cables certified for most mud types
- Halogen-free ICEFLEX™ cables operational down to -65°C
- UV-resistance up to 6 GJ/m²
- Superior EMC and dielectric performance for VFD cables

Cable Installation

To facilitate easy bending and rerouting, less weight for overall topside weight reduction, easy handling and cable pulling, significantly reducing installation manpower:

- Increased and improved number of strands on cables
- 2-4% total cable-weight reduction for most projects
- Low-friction jacketing and easy strippability saving up to 10% manpower
- Reduced Maintenance Repair and Overhaul (MRO) costs

Full Electrical System Offer

To increase flexibility, protection, strength, safety and connectivity through modular systems, special packages and complete kits:

- Expertise on connectivity
- Termination kits and cable gland solutions
- High-quality components and innovative solutions to protect service loops in the harshest environments
- Enhanced end-user safety

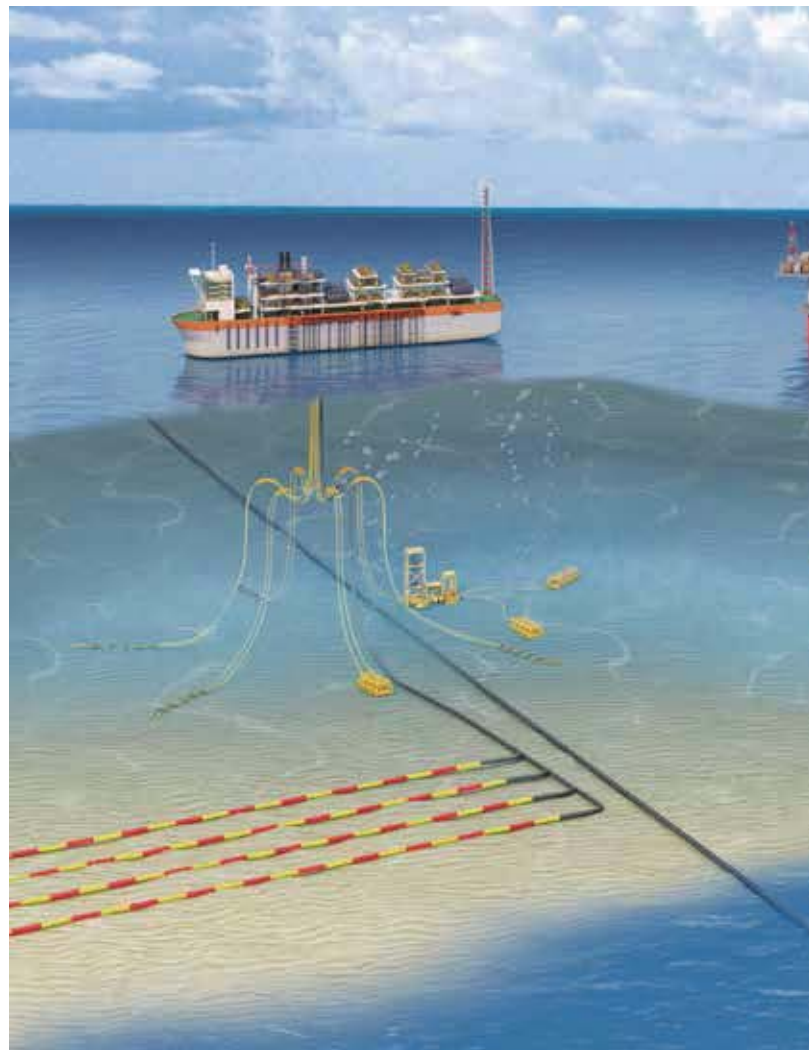

Services and Quality

To shorten lead times, increase availability, reduce the number of cable type references, optimize sizing and routing, solve problems, eliminate scrap, provide testing, improve designs and assure certification:

- 98% On Time Delivery and fast emergency handling
- Global inventory: US, China, Singapore, Middle East, UK, Norway
- One-stop shopping and tailor-made solutions
- Optimized cable lengths and tagging on reels
- On-site engineering and electrical system design review
- Testing, root cause analysis, statistical quality control, certification
- Ongoing partnership with Oil & Gas upstream engineers



ICEFLEX® cables



LV/MV power control and instrumentation IEC



LV/MV power, control and instrumentation IEEE1580



HV power cables and accessories



Data cables



Bridles and assemblies



Service loops



Variable Frequency Drive cables





Contents

General Introduction

Cable Construction Detail

Cable designation

Reference standard

Why need LSHF cables?

What are LSHF cables?

Flame retardant and Fire resistance

Definition of terms

Cable Construction Detail

8.7/15kV(17.5kV) RFOU

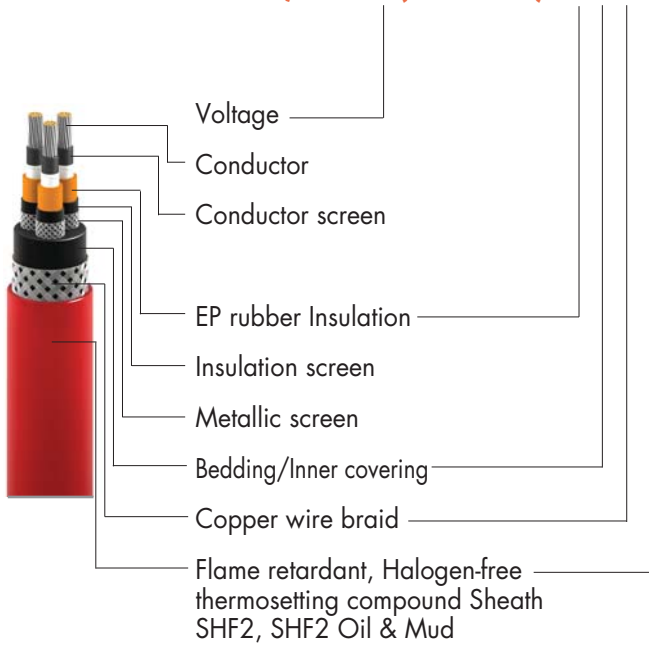

0.6/1kV BFOU

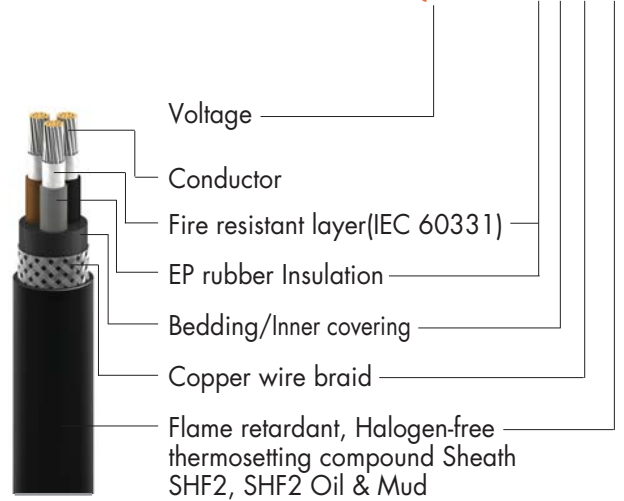

250V RFOU(I)

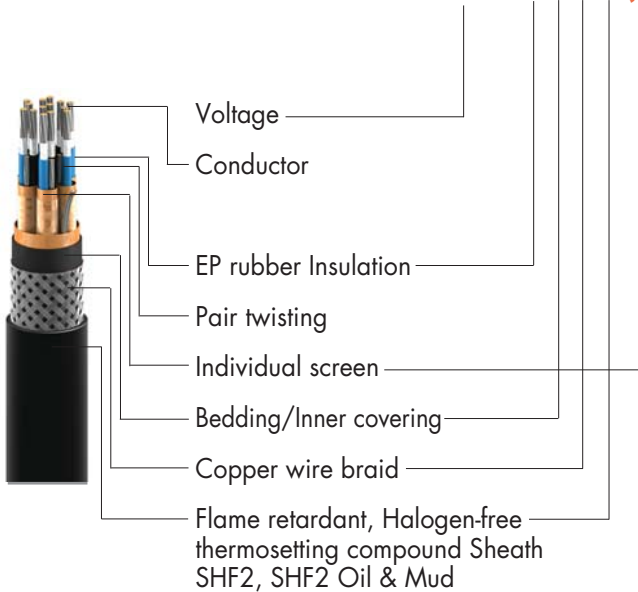

0.6/1kV RX,UX

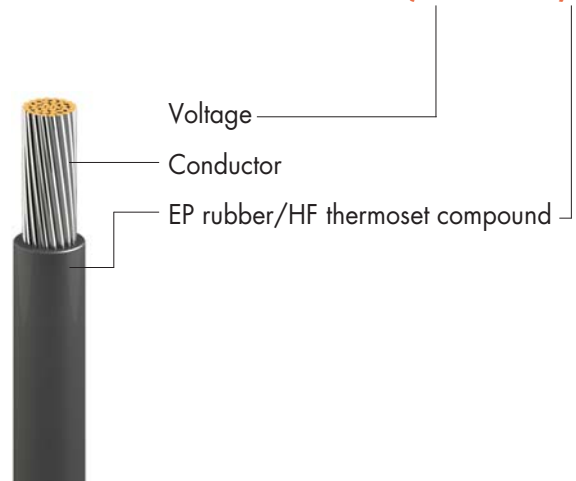

Cable designation according to NEK TS 606 | Symbol

Primary insulation	Bedding	Armor	Jacket (Sheath)	Group shielding	Electro magnetic Interference	Flexibility
R Ethylene Propylene Rubber(EPR)	F Bedding/Inner covering (Halogen free) or taping	O Copper wire braid	U Flame & oil resistant Halogen-free thermosetting compound SHF2 or SHF2 Oil & Mud	(C) Collective screen with drain wire	EMC Used for Variable Frequency Drive	FLEX Flexible conductor
B Fire resistant tape/EP rubber		C Galvanized steel wire braid		(I) Individual shield with drainwire		
T Cross-linked Polyethylene(XLPE)				(I/C) Individual & collective screen with drain wire		
S Cross-linked Silicone rubber						

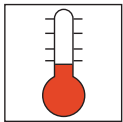

Temperature

Admissible ambient temperature for continuous duty operation



Flexibility



Fire Performance

Fire performance according to;

- Flame retardant IEC 60332-1
- Flame retardant IEC 60332-3 Category A,
- Fire resistant IEC 60331-1/2/21
- Water spray EN50200 : Annex E

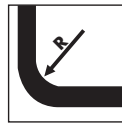

Bending Radius



Cold Behavior

Cable mechanical resistance to impact (-40~-35°C) (-65°C ICEFLEX™)



Halogen free

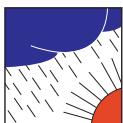

Weather

Resistance to severe weather conditions



Electro Magnetic Interference

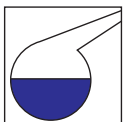

Chemical attacks

Resistance to chemical



Mineral Oil

Resistance to Enhanced Oil & Hydraulic / gear oil

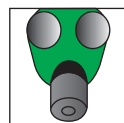
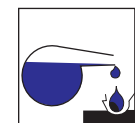

Smoke-Corrosivity-Toxicity

Smoke density, gases corrosivity and toxicity



Mud

Resistance to Mud
NEK TS 606

Reference standard

IEC Pub. 60092-3 (Amend No.1~No.6)	Electrical installations in ships. Part 3 : Cables (construction, testing and installations)
IEC Pub. 60092-350	Electrical installations in ships. Part 350 : General construction & test methods of power, control and instrumentation cables for shipboard & offshore application
IEC Pub. 60092-352	Electrical installations in ships. Part 352 : Choice and installation of electric cables
IEC Pub. 60092-353	Electrical installations in ships. Part 353 : Power cables for rated voltages 1kV and 3kV
IEC Pub. 60092-354	Electrical installations in ships. Part 354: Single-and three-core power cables with extruded solid insulation for rated voltages 6 kV (Um = 7,2 kV) up to 30 kV (Um = 36 kV)
IEC Pub. 60092-360	Electrical installations in ships. Part 360 : Insulating and Sheathing materials for shipboard and offshore units, power, control Instrumentation and telecommunication cables.
IEC Pub. 60092-376	Electrical installation in ships Part 376 : Cables for control and instrumenatation circuits 150/250V (300V)
IEC Pub. 60228	Conductors of insulated cables
IEC Pub. 60331series	Fire-resisting characteristics of electric cables
IEC Pub. 60332-1	Tests on electric cables under fire condition. Part 1 : Tests on a single vertical insulated wire or cable.
IEC Pub. 60332-3	Tests on electric cables under fire conditions. Part 3 : Test on bunched wires or cables.
IEC Pub. 60684-2	Flexible Insulating Sleeving Part 2 : Method of Test
IEC Pub. 60754-1	Test on gases evolved during combustion of materials from cables Part 1 : Determination of the amount of halogen acid gas
IEC Pub. 60754-2	Test on gases evolved during combustion of materials from cables Part 2 : Determination of degree of acidity of gases evolved during the combustion of materials taken from electric cables by measuring pH and conductivity
IEC Pub. 61034-1	Measurement of smoke density of cables during under conditions Part 1 : Test apparatus.
IEC Pub. 61034-2	Measurement of smoke density of cables during under conditions Part 2 : Test procedure and requirements.
NEK TS 606-2016	Cables for Offshore Installations
ASTM D 2863	Standard Method for Measuring the minimum Oxygen Concentration to support candle-like Combustion of plastics (Oxygen Index)
CSA C22.2 No. 03	Test Methods for Electrical Wires and Cables
CSA C22.2 No. 38	Thermosetting-insulated Wires and Cables
UL 1581	Reference Standard for Electric wires, Cables, and Flexible Cords
BS EN 50200 Annex E	Method of test for resistant to fire of unprotected small cables for use in emergency circuits. Annex E guidance for using optional water spray protocol

Why need LSHF cables?

Flame Propagation

During a fire, if the source of flames does not die out, it may cause all electric system down and secondary effects such as smoke, toxicity, corrosion, etc.

Smoke

Smoke evolution is of major significance in situation where escape routes are obscured in the event of fire.

Toxicity

The toxic gases are disturbing rescue activity and may cause escaper to suffocation of death.

Corrosion

When halogen containing cables burn, the gases generated in combustion of cables may cause corrosion damage to various expensive metal equipments.

Mud resistance

The suitability of sheathing materials for use in areas in which the cables are exposed to drilling fluids is heavy dependent upon the type of fluid present. Each type of fluid contains additives which can have a deleterious effect on the sheathing material

Here is Our Answer.

Nexans Kukdong LSHF CABLES



What are LSHF cables?



LSHF = Low Smoke and Halogen Free

Flame retardant and Fire resistance



Cable Type	Flame retardant cable	Fire resisting cable
Main Purpose	Non-Flame Propagation	Circuit Integrity
Circuit Status	Down	Alive
Test Method	IEC 60332-1 IEC 60332-3	IEC 60331series

Definition of terms

- **Flame retardance**

The cables shall withstand the test specified in IEC 60332-3.

Single, earth and bonding wires shall withstand the test specified in IEC 60332-1 or IEC 60332-2

- **Fire resistance**

Fire resistant cables shall be tested according to IEC 60331 series.

- **Content of halogen**

To demonstrate that the cables are halogen-free, they shall be tested to IEC 60754-1, maximum content of halogen shall not exceed 5mg/g(0.5%).

- **Acid gas evolution of combustion materials**

To demonstrate that the cables are halogen-free, they shall be tested to IEC 60754-2, the weighted pH value shall not be less than 4.3, when related to 1 liter of water. And the weighted value of conductivity shall not exceed 10 μ S/mm.

- **Smoke emission**

During a cable fire, the smoke emission shall be tested in accordance with IEC 61034-1 and IEC 61034-2, minimum 60% of the transmitted light must penetrate the smoke.

- **Toxicity**

The toxicity shall be tested in accordance with NES 713, the maximum toxicity index shall not exceed 5.

- **Enhanced oil Resistance (Hydrocarbon)**

All thermoset sheathed cables shall be suitable for an oil production installation. The oil resistance properties shall be demonstrated by a test according to NEK 606, with the cable immersed in IRM 902 & IRM 903 respectively at 100°C for 168 hours.

For cables with thermoplastic sheath material, there are no requirements for oil resistance properties.

- **Mud Resistance (Hydrocarbon)**

Mud resistant cables shall be designed with sheathing compounds suitable for installation and operation in contact with Mud unless otherwise specified.

The Mud resistance properties shall be demonstrated by a test according to NEK TS 606 with the cable immersed in Mud at 70°C for 56 days.

- **Hydraulic / gear oil resistance**

Types of hydraulic test oil shall be specified by cable manufacturer. The hydraulic resistance properties shall be demonstrated by a test according to NEK606, with the cable immersed in hydraulic / gear oil at 100°C for 7 days.



Contents

Cable Selection Guide

Voltage Rating Selection

Voltage drop

Short circuit current rating

Part Number Code

High Voltage Flame retardant cable

- 3.6/6kV RFOU
- 6/10kV RFOU
- 8.7/15kV RFOU

High Voltage Flame & Fire resistant cable

- 3.6/6kV RFOU-Fire resistance
- 6/10kV RFOU-Fire resistance

Low Voltage Flame retardant cable

- Power and control cable
- Instrument cable
- Earthing & Bonding cable
- VFD cable

Low Voltage Flame & Fire resistant cable

- Power and control cable
- Instrument cable
- VFD cable

Voltage Rating Selection

Selection of Cables for a.c. Systems

Supply System	System Category	System Voltage(kV)					Recommended Voltage Designation	
		Phase to Earth (U ₀)		Phase to Phase (U)		Maximum Sustained Voltage (U _m)	IEC Standards	BS Standards
		Above	Up to and including	Above	Up to and including		kV	kV
3-Phase 4-Wire	A, B & C	-	0.15	-	0.25	0.28	0.15/0.25	0.15/0.25
		0.15	0.6	0.25	1	1.2	0.6/1	0.6/1
3-Phase 3-Wire	A & B	-	0.15	-	0.25	0.28	0.15/0.25	0.15/0.25
		0.15	0.6	0.25	1	1.2	0.6/1	0.6/1
		0.6	1.9	1	3.3	3.6	1.8/3	1.9/3.3
		1.9	3.8	3.3	6.6	7.2	3.6/6	3.8/6.6
		3.8	6.35	6.6	11	12	6/10	6.35/11
		6.35	8.7	11	15	17	8.7/15	-
		8.7	12.7	15	22	24	12/20	12.7/22
3-Phase 3-Wire	C	-	-	-	0.15	-	0.15/0.25	0.15/0.25
		-	-	0.15	0.6	-	0.6/1	0.6/1
		-	-	0.6	1.9	-	1.8/3	1.9/3.3
		-	-	1.9	3.3	3.6	3.6/6	3.8/6.6
		-	-	3.3	6.5	7.2	6/10	6.35/11
		-	-	6.6	11	12	8.7/15	11/11
		-	-	11	15	17.5	12/20	12.7/22
2-Phase 3-Wire or 2-Phase 4-Wire	A & B	-	0.15	-	0.21	-	0.15/0.25	0.15/0.25
		0.15	0.6	-	0.84	-	0.6/1	0.6/1
2-Phase 3-Wire or 2-Phase 4-Wire	C	-	-	-	0.15	-	0.15/0.25	0.15/0.25
		-	-	0.15	0.6	-	0.6/1	0.6/1
		-	-	0.6	1.9	-	1.8/3	1.9/3.3
1-Phase 3-Wire	A & B	-	0.15	-	0.25	0.28	0.15/0.25	0.15/0.25
		0.15	0.6	0.25	1	1.2	0.6/1	0.6/1
1-Phase 3-Wire	C	-	-	-	0.15	-	0.15/0.25	0.15/0.25
		-	-	0.25	0.6	-	0.6/1	0.6/1
1-Phase 2-Wire or 1-Phase 1-Wire	C	-	-	-	0.15	-	0.15/0.25	0.15/0.25
		-	-	0.15	0.6	-	0.6/1	0.6/1
		-	-	0.6	1.9	-	1.8/3	1.9/3.3
		-	-	1.9	3.3	3.6	3.6/6	3.8/6.6
		-	-	3.3	6.6	7.2	6/10	6.35/11
		-	-	6.6	11	12	8.7/15	-

Note

The rated voltage of the cable for a given application shall be suitable for the operating conditions in the system in which the cable is used. To facilitate the selection of the cable, systems are divided into three categories.

Category A ; This category comprises those systems in which any phase conductor that comes in contact with earth or an earth conductor, is automatically disconnected from the system within 1 minute.

Category B ; This category comprises those systems which, under fault conditions, are operated for a short time, not exceeding 8 hours on any occasion, with one phase earthed.

In any case, the expected total duration of earth faults in any year should not exceed 125 hours.

Category C ; This category comprises all systems which do not fall into categories A and B.

Voltage Drops

Line-to-Neutral Voltage Drop for 0.6/1kV in Normal Conditions Service

No. of Core	Nominal cross section area	Voltage Drop ("Vd") at 50Hz & 90°C Conductor temperature (mV/A-m)					Voltage Drop ("Vd") at 60Hz & 90°C Conductor temperature (mV/A-m)				
		Power Factor					Power Factor				
	mm ²	60%	70%	80%	90%	100%	60%	70%	80%	90%	100%
Single core Cable (EPR)	1.5	9.47	11.01	12.54	14.07	15.56	9.49	11.03	12.57	14.09	15.56
	2.5	5.91	6.86	7.8	8.74	9.64	5.93	6.88	7.82	8.76	9.64
	4	3.71	4.3	4.88	5.46	5.99	3.74	4.32	4.9	5.47	5.99
	6	2.49	2.87	3.25	3.63	3.97	2.51	2.89	3.27	3.64	3.97
	10	1.51	1.73	1.95	2.17	2.35	1.53	1.75	1.97	2.18	2.35
	16	0.98	1.12	1.25	1.38	1.48	1	1.14	1.27	1.39	1.48
	25	0.65	0.73	0.82	0.89	0.94	0.67	0.75	0.83	0.9	0.94
	35	0.49	0.55	0.6	0.65	0.67	0.51	0.56	0.62	0.66	0.67
	50	0.38	0.42	0.46	0.49	0.5	0.4	0.44	0.47	0.5	0.5
	70	0.29	0.31	0.34	0.35	0.34	0.3	0.33	0.35	0.36	0.34
	95	0.23	0.24	0.26	0.27	0.25	0.24	0.26	0.27	0.28	0.25
	120	0.19	0.2	0.21	0.22	0.2	0.21	0.22	0.22	0.23	0.2
	150	0.17	0.18	0.18	0.19	0.16	0.19	0.19	0.2	0.19	0.16
	185	0.15	0.15	0.16	0.16	0.13	0.16	0.17	0.17	0.16	0.13
	240	0.13	0.13	0.13	0.13	0.1	0.14	0.14	0.14	0.13	0.1
	300	0.12	0.12	0.12	0.11	0.08	0.13	0.13	0.13	0.12	0.08
	430	0.11	0.11	0.1	0.09	0.06	0.12	0.12	0.11	0.1	0.06
500	0.1	0.09	0.09	0.08	0.05	0.11	0.11	0.1	0.09	0.05	
630	0.09	0.09	0.08	0.07	0.04	0.1	0.1	0.09	0.08	0.04	
Multi core Cable (EPR)	1.5	9.42	10.97	12.51	14.05	15.56	9.44	10.98	12.52	14.06	15.56
	2.5	5.87	6.82	7.77	8.72	9.64	5.88	6.83	7.79	8.73	9.64
	4	3.67	4.26	4.85	5.44	5.99	3.69	4.28	4.86	5.44	5.99
	6	2.45	2.84	3.23	3.61	3.97	2.47	2.85	3.24	3.62	3.97
	10	1.48	1.7	1.93	2.15	2.35	1.49	1.71	1.94	2.16	2.35
	16	0.95	1.09	1.23	1.37	1.48	0.96	1.10	1.24	1.37	1.48
	25	0.62	0.71	0.8	0.88	0.94	0.64	0.72	0.81	0.88	0.94
	35	0.47	0.53	0.59	0.64	0.67	0.48	0.54	0.59	0.65	0.67
	50	0.36	0.4	0.44	0.48	0.50	0.37	0.41	0.45	0.49	0.50
	70	0.27	0.29	0.32	0.34	0.34	0.28	0.31	0.33	0.35	0.34
	95	0.21	0.23	0.24	0.26	0.25	0.22	0.24	0.25	0.26	0.25
	120	0.18	0.19	0.20	0.21	0.20	0.19	0.20	0.21	0.21	0.20
	150	0.15	0.16	0.17	0.18	0.16	0.17	0.17	0.18	0.18	0.16
185	0.13	0.14	0.15	0.15	0.13	0.15	0.15	0.15	0.15	0.13	
240	0.12	0.12	0.12	0.12	0.10	0.13	0.13	0.13	0.12	0.10	
300	0.10	0.10	0.10	0.10	0.08	0.12	0.11	0.11	0.11	0.08	

Note

1. These Voltage Drops can be applied to the cables of conductor temperature 90°C and 0.6/1kV voltage rating.
2. These Values are based on the system of Single or 3-Phase Line-to-Neutral Voltage Drop.
3. The voltage drops for single-core cables are based on three-foil formation.
4. For Single Phase Line-to-Line Voltage Drop, Multiply "Vd" value by 2.0.
5. For 3-Phase Line-to-Line Voltage Drop, Multiply "Vd" value by 1.732.

Applicable Formulas ;

$$1. \% \text{ Voltage drop} = \frac{\text{"Vd"} \times \text{Amp.} \times \text{Cable Length}}{\text{Line Voltage} \times 1000}$$

$$2. \text{Cable Length(m)} = \frac{\% \text{ Voltage Drop} \times \text{Line Voltage} \times 1000}{\text{"Vd"} \times \text{Amp.}}$$

$$3. \text{"Vd"} = \frac{\% \text{ Voltage Drop} \times \text{Line Voltage} \times 1000}{\text{Cable Length} \times \text{Amp.}}$$

Short Circuit Current Rating

According to IEC 60724

Nominal cross section area mm ²	Fault Current at 250°C									
	Duration									
	0.1 sec.	0.2 sec.	0.3 sec.	0.4 sec.	0.5 sec.	0.6 sec.	0.7 sec.	0.8 sec.	0.9 sec.	1.0 sec.
	kA	kA	kA	kA	kA	kA	kA	kA	kA	kA
1.5	0.68	0.48	0.39	0.34	0.30	0.28	0.26	0.24	0.23	0.21
2.5	1.13	0.80	0.65	0.57	0.51	0.46	0.43	0.40	0.38	0.36
4	0.81	1.28	1.04	0.90	0.81	0.74	0.68	0.64	0.60	0.57
6	2.71	1.92	1.57	1.36	1.21	1.11	1.03	0.96	0.90	0.86
10	4.52	3.20	2.61	2.26	2.02	1.85	1.71	1.60	1.51	1.43
16	7.24	5.12	4.18	3.62	3.24	2.96	2.74	2.56	2.41	2.29
25	11.31	8.00	6.53	5.66	5.06	4.62	4.28	4.00	3.77	3.58
35	15.84	11.20	9.14	7.92	7.08	6.47	5.99	5.60	5.28	5.01
50	22.62	16.00	13.06	11.31	10.12	9.24	8.55	8.00	7.54	7.15
70	31.67	22.40	18.29	15.84	14.16	12.93	11.97	11.20	10.56	10.02
95	42.98	30.39	24.82	21.49	19.22	17.55	16.25	15.20	14.33	13.59
120	54.30	38.39	31.35	27.15	24.28	22.17	20.52	19.20	18.10	17.17
150	67.87	47.99	39.19	33.94	30.35	27.71	25.65	24.00	22.62	21.46
185	83.71	59.19	48.33	41.85	37.43	34.17	31.64	29.59	27.90	26.47
240	108.59	76.79	62.70	54.30	48.56	44.33	41.04	38.39	36.20	34.34
300	135.74	95.98	78.37	67.87	60.71	55.42	51.31	47.99	45.25	42.93
400	180.99	127.98	104.49	90.49	80.94	73.89	68.41	63.99	60.33	57.23
500	226.23	159.97	130.62	113.12	101.18	92.36	85.51	79.99	75.41	71.54
630	285.06	201.57	164.58	142.53	127.48	116.37	107.74	100.78	95.02	90.14

Part Number Code

NEK 606	1 st letter	Construction	2 nd letter	Fire fighting	3 rd letter	Voltage (IEC)	4 th letter	Size
							No. of core	
Q	B	RX/UX	T	Flame retardant	A	150/250V	XXC(P,T,Q,E)	XXX
	C	RU/BU	X	Fire resistant(Mica)	D	0.6/1KV	03C(3Core)	0 <u>75</u> (0.75mm ²)
	E	RFOU/BFOU/SFOU	S	Fire resistant(without Mica)	E	1.8/3KV	04E(3C+E)	0 <u>15</u> (1.5mm ²)
	Q	RU(I)/BU(I)			F	3.6/6KV	04P(4Pair)	120(120mm ²)
	S	RFOU(I)/BFOU(I)/SFOU(I)			G	6/10KV	12T(12Triad)	All decimal points shall be written as an upderbar, for example, 0.75 = 0 <u>75</u> 1.5 = 0 <u>15</u> 2.5 = 0 <u>25</u>
	T	RU(C)/BU(C)			H	8.7/15KV	2Q(2Quad)	
	V	RFOU(C)/BFOU(C)/SFOU(C)			J	12/20KV	06E(3C+3E)	
	X	VFD			K	18/30KV		

For Class 5 conductor Type, 'F' shall be added in front of the Part Number.

*Note(1) Example : 0.6/1KV-RFOU-EMC(FLEX)25mm²x3C+3E | 0.6/1kv BFOU 120mm²x3C
Part No. **F-QETD06E025** | Part No. **QEXD03C120**

*Note(2) In case of Oil & Mud resistant cables, "Type-" shall be added in front of the Part Number
"no marking" : Minimum requirement
Type "E" : Enhanced oil resistant - category b
Type "M" : Enhanced oil resistant - category b & Mud resistance - category c
Type "H" : Enhanced oil resistant - category b & Hydraulic/gear oil resistance - category d
Type "H-M" : Enhanced oil resistant - category b & Mud resistance - category c & Hydraulic/gear oil resistance - category d
Example : 0.6/1kv RFOU - EMC (FLEX)25mm² X 3C+3E for Enhanced oil resistant cable
Part No. : EF - QETD06E025



Application

- Power circuit above 1kV.
- Fixed installation in both explosion risk and safe areas.
- Medium voltage power cables for general purpose.
- Maximum operating conductor temperature 90°C.

Construction Details

- 1 Conductor** : Circular tinned stranded copper as per IEC 60228, Class 2
- 2 Conductor screen** : Semi-conducting tape and/or Semi-conducting compound
- 3 Insulation** : Halogen Free Ethylene Propylene Rubber(EPR) as per IEC 60092-360
- 4 Insulation screen** : Semi-conducting compound and Semi-conducting tape
- 5 Metallic screen** : Copper(annealed or tinned) wires braid as per IEC 60092-354
- 6 Cabling** (with filler, binder tapes over the assembly of laid-up cores)
- 7 Sheath** : Flame retardant, Halogen-free thermosetting compound as per IEC 60092-360, SHF2
- 8 Armor** : Copper wires braid(screen) as per IEC 60092-354
— RFCU(option) : Galvanized steel wire braid as per IEC 60092-354
- 9 Sheath** : Halogen-free thermosetting compound as per IEC 60092-360, SHF2 or SHF2 Oil & Mud

Standard Applied

- **Design guideline** : IEC 60092-354, NEK 606
- **Material properties** : IEC 60092-360, Insulation(EPR)
IEC 60092-360, Sheath(SHF2)
- **Flame retardant** : IEC 60332-3, Cat. 'A'
- **Assessment of halogen** : IEC 60754-1/2 & 60684-2
- **Low smoke properties** : IEC 61034-1/2
- **Sunlight resistance** : UL 1581
- **Cold properties(option)** : CSA C22.2 No. 03. Cold bending(-50°C), Cold impact(-50°C)
- **Oil/Mud resistance(option)** : NEK TS 606-2016 5th ed (Category a, b, c, d)

Note 1)

Cross section of Armor (for 2, 3, 4 core cable)

Cross section Q of associated current carrying conductor	Min. cross section of braiding wire
$Q \leq 16\text{mm}^2$	Q
$Q > 16\text{mm}^2$	1/2 of the current-carrying conductor, but not less than 16mm ²

Approvals

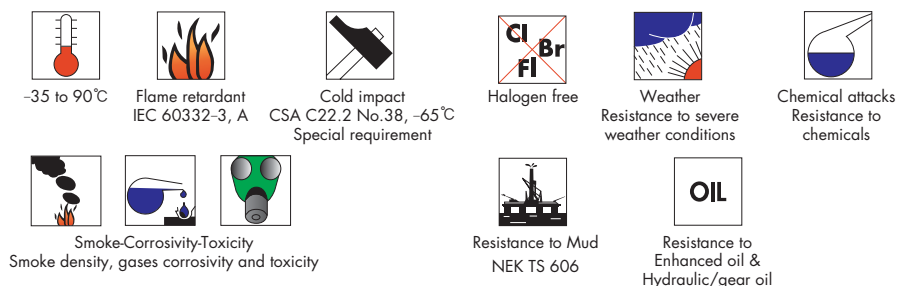
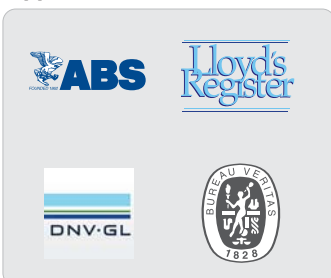

3.6/6(7.2)kV Armored Flame retardant, Halogen free High voltage Power Cable (Code : 3.6/6kV RFOU[P102])

No. of core	Part no.	Conductor			Thickness of insulation	Thickness of inner covering	Nominal dia. over inner covering	Dia. of metal wire for braid	Thickness of outer sheath	Nominal overall dia.	Cable weight approx	Conductor resistance (20°C)	Current rating at 45°C
		Nominal sectional area	Min. No. of wires	Max. overall dia.									
EA	QETF	mm ²	EA	mm	mm	mm	mm	mm	mm	kg/km	Ω /km	Amp.	
1	01C016	16/4	7	5.3	3.0	1.4	18.6	0.3	1.1	22.8±0.9	780	1.16	96
	01C025	25/9	7	6.6	3.0	1.5	20.1	0.3	1.1	24.3±1.0	930	0.734	127
	01C035	35/9	7	7.9	3.0	1.5	21.3	0.3	1.2	25.7±1.0	1080	0.529	157
	01C050	50/10	19	9.1	3.0	1.6	22.8	0.3	1.2	27.2±1.1	1260	0.391	196
	01C070	70/10	19	11.0	3.0	1.6	24.6	0.3	1.3	29.2±1.2	1540	0.270	242
	01C095	95/12	19	12.9	3.0	1.7	26.7	0.3	1.3	31.3±1.3	1870	0.195	293
	01C120	120/13	37	14.5	3.0	1.8	28.5	0.3	1.4	33.8±1.3	2200	0.154	339
	01C150	150/16	37	16.2	3.0	1.8	30.0	0.3	1.4	34.8±1.4	2520	0.126	389
	01C185	185/16	37	18.0	3.0	1.9	32.1	0.4	1.5	37.6±1.5	3070	0.100	444
	01C240	240/18	61	20.6	3.0	2.0	34.9	0.4	1.5	40.4±1.6	3740	0.0762	522
	01C300	300/26	61	23.1	3.0	2.1	37.5	0.4	1.6	43.2±1.7	4460	0.0607	601
	01C400	400/29	61	26.1	3.0	2.2	40.7	0.4	1.7	46.6±1.9	5420	0.0475	719
	01C500	500/33	61	29.2	3.2	2.4	44.7	0.4	1.8	50.8±2.0	6610	0.0369	827
	01C630	630/33	91	33.2	3.2	2.5	48.8	0.4	1.9	55.1±2.2	8170	0.0286	955
3	03C016	16/16	7	5.3	3.0	2.2	39.2	0.4	1.6	44.9±1.8	2930	1.16	67
	03C025	25/16	7	6.6	3.0	2.3	42.2	0.4	1.7	48.1±1.9	3500	0.734	89
	03C035	35/16	7	7.9	3.0	2.4	45.0	0.4	1.8	51.1±2.0	4080	0.529	110
	03C050	50/25	19	9.1	3.0	2.5	48.0	0.4	1.9	54.3±2.2	4750	0.391	137
	03C070	70/35	19	11.0	3.0	2.7	52.3	0.4	2.0	58.8±2.4	5830	0.270	169
	03C095	95/50	19	12.9	3.0	2.8	56.6	0.4	2.1	63.3±2.5	7080	0.195	205
	03C120	120	37	14.5	3.0	3.0	60.4	0.4	2.2	67.3±2.7	8260	0.154	237
	03C150	150	37	16.2	3.0	3.1	63.9	0.4	2.3	71.0±2.8	9490	0.126	272
	03C185	185	37	18.0	3.0	3.3	68.8	0.4	2.4	75.8±3.0	10660	0.100	311
	03C240	240	61	20.6	3.0	3.5	75.1	0.4	2.5	82.3±3.3	12940	0.0762	365
	03C300	300	61	23.1	3.0	3.8	81.7	0.4	2.7	89.3±3.6	12660	0.0607	421
	03C120*	120/60*	37	14.5	3.0	3.0	60.4	0.4 ^{1/2}	2.2	68.8±2.8	9260	0.154	237
	03C150*	150/70*	37	16.2	3.0	3.1	63.9	0.4 ^{1/2}	2.3	72.5±2.0	10545	0.126	272
	03C185*	185/95*	37	18.0	3.0	3.3	68.8	0.45 ^{1/2}	2.4	78.1±3.1	12485	0.100	311
03C240*	240/120*	61	20.6	3.0	3.5	75.1	0.5 ^{1/2}	2.6	85.2±3.4	15430	0.0762	365	
3+E	04E016	25	7	6.6	3.0	2.3	42.5	0.4	1.7	48.2±1.9	4010	0.734	89
		16E	7	5.3	1.0							1.16	
	04E035	35	7	7.9	3.0	2.4	45.9	0.4	1.8	51.8±2.1	4770	0.529	110
		25E	7	6.6	1.2							0.734	
	04E050	50	19	9.1	3.0	2.5	48.5	0.4	1.9	54.7±2.2	5440	0.391	137
		25E	7	6.6	1.2							0.734	
	04E070	70	19	11.0	3.0	2.7	53.0	0.4	2.0	59.3±2.4	6650	0.270	169
		35E	7	7.9	1.2							0.529	
	04E095	95	19	12.9	3.0	2.9	57.9	0.4	2.1	64.4±2.6	8150	0.195	205
		50E	19	9.1	1.4							0.391	
	04E120	120	37	14.5	3.0	3.0	62.0	0.4	2.2	68.7±2.8	9590	0.154	237
		70E	19	11.0	1.4							0.270	
	04E150	150	37	16.2	3.0	3.2	66.5	0.4	2.3	73.4±2.9	11240	0.126	272
		95E	19	12.9	1.6							0.195	

Example) 3.6/6kV RFOU 1C x16mm² Part No. QETF01C016

Note) "*" double braided(option)

Q NEK606	E RFOU	T Flame retardant	F 3.6/6kV	01C No. of cores	016 Size (mm ²)
--------------------	------------------	-----------------------------	---------------------	----------------------------	---------------------------------------

High Voltage Flame Retardant Cable

High Voltage Flame & Fire Resistant Cable

Low Voltage Flame Retardant Cable

Low Voltage Flame & Fire Resistant Cable

Technical information

6/10(12)kV Armored Flame retardant, Halogen free High voltage Power Cable (Code : 6/10kV RFOU[P103])

No. of core	Part no.	Conductor			Thickness of insulation	Thickness of inner covering	Nominal dia. over inner covering	Dia. of metal wire for braid	Thickness of outer sheath	Nominal overall dia.	Cable weight approx	Conductor resistance (20°C)	Current rating at 45°C
		Nominal sectional area	Min. No. of wires	Max. overall dia.									
EA	QETG	mm ²	EA	mm	mm	mm	mm	mm	mm	kg/km	Ω/km	Amp.	
1	01C016	16/4	7	5.3	3.4	1.5	19.6	0.3	1.1	23.8±1.0	830	1.16	96
	01C025	25/9	7	6.6	3.4	1.5	20.9	0.3	1.1	25.3±1.0	980	0.734	127
	01C035	35/9	7	7.9	3.4	1.6	22.3	0.3	1.2	26.7±1.1	1130	0.529	157
	01C050	50/10	19	9.1	3.4	1.6	23.6	0.3	1.2	28.0±1.1	1300	0.391	196
	01C070	70/10	19	11.0	3.4	1.7	25.6	0.3	1.3	30.2±1.2	1600	0.270	242
	01C095	95/12	19	12.9	3.4	1.8	27.7	0.3	1.3	32.3±1.3	1940	0.195	293
	01C120	120/13	37	14.5	3.4	1.8	29.3	0.3	1.4	34.1±1.4	2260	0.154	339
	01C150	150/16	37	16.2	3.4	1.9	31.0	0.3	1.4	36.3±1.5	2670	0.126	389
	01C185	185/16	37	18.0	3.4	2.0	33.1	0.4	1.5	38.6±1.5	3140	0.100	444
	01C240	240/18	61	20.6	3.4	2.1	35.9	0.4	1.5	41.6±1.7	3840	0.0762	522
	01C300	300/26	61	23.1	3.4	2.2	38.5	0.4	1.6	44.2±1.8	4540	0.0607	601
	01C400	400/29	61	26.1	3.4	2.3	41.7	0.4	1.7	47.6±1.9	5510	0.0475	719
	01C500	500/33	61	29.2	3.4	2.4	45.1	0.4	1.8	51.2±2.0	6650	0.0369	827
	01C630	630/33	91	33.2	3.4	2.6	49.4	0.4	1.9	55.7±2.2	8240	0.0286	955
3	03C016	16/16	7	5.3	3.4	2.3	41.1	0.4	1.7	47.0±1.9	3150	1.16	67
	03C025	25/16	7	6.6	3.4	2.4	44.1	0.4	1.8	50.2±2.0	3730	0.734	89
	03C035	35/16	7	7.9	3.4	2.5	46.9	0.4	1.8	53.0±2.1	4300	0.529	110
	03C050	50/25	19	9.1	3.4	2.6	49.9	0.4	1.9	56.2±2.2	4990	0.391	137
	03C070	70/35	19	11.0	3.4	2.7	54.0	0.4	2.0	60.5±2.4	6060	0.270	169
	03C095	95/50	19	12.9	3.4	2.9	58.5	0.4	2.1	65.2±2.6	7350	0.195	205
	03C120	120	37	14.5	3.4	3.0	62.2	0.4	2.2	69.1±2.8	8530	0.154	237
	03C150	150	37	16.2	3.4	3.2	65.8	0.4	2.3	72.9±2.9	9790	0.126	272
	03C185	185	37	18.0	3.4	3.4	70.8	0.4	2.4	77.8±3.1	11100	0.100	311
	03C240	240	61	20.6	3.4	3.6	77.9	0.4	2.6	85.3±3.4	13700	0.0762	365
	03C300	300	61	23.1	3.4	3.6	83.4	0.4	2.7	91.0±3.6	16110	0.0607	421
	03C120*	120/60*	37	14.5	3.4	3.0	62.2	0.4 ^{1/2}	2.2	70.6±2.8	9590	0.154	237
	03C150*	150/70*	37	16.2	3.4	3.2	65.8	0.4 ^{1/2}	2.3	74.4±3.0	10910	0.126	272
	03C185*	185/95*	37	18.0	3.4	3.4	70.8	0.45 ^{1/2}	2.5	80.3±3.2	12940	0.100	311
03C240*	240/120*	61	20.6	3.4	3.6	77.9	0.5 ^{1/2}	2.7	88.2±3.5	16110	0.0762	365	
3+E	04E016	25	7	6.6	3.0	2.4	44.3	0.4	1.8	50.2±1.9	4260	0.734	89
		16E	7	5.3	1.0							1.16	
	04E035	35	7	7.9	3.0	2.5	47.6	0.4	1.8	53.5±2.1	4990	0.529	110
		25E	7	6.6	1.2							0.734	
	04E050	50	19	9.1	3.0	2.6	50.3	0.4	1.9	56.4±2.3	5670	0.391	137
		25E	7	6.6	1.2							0.734	
	04E070	70	19	11.0	3.0	2.8	54.8	0.4	2.0	61.1±2.4	6920	0.270	169
		35E	7	7.9	1.2							0.529	
	04E095	95	19	12.9	3.0	2.9	59.4	0.4	2.1	65.9±2.6	8370	0.195	205
		50E	19	9.1	1.4							0.391	
	04E120	120	37	14.5	3.0	3.1	63.8	0.4	2.2	70.5±2.8	9880	0.154	237
		70E	19	11.0	1.4							0.270	
	04E150	150	37	16.2	3.0	3.3	68.2	0.4	2.4	75.3±3.0	11570	0.126	272
		95E	19	12.9	1.6							0.195	

Note) "*" double braided (option)

Example) 6/10kV RFOU 1C x16mm² Part No. QETG01C016

Q NEK606	E RFOU	T Flame retardant	G 6/10kV	01C No. of cores	016 Size (mm ²)
--------------------	------------------	-----------------------------	--------------------	----------------------------	---------------------------------------

8.7/15(17.5)kV Armored Flame retardant, Halogen free High voltage Power Cable (Code : 8.7/15kV RFOU [P104])

No. of core	Part no.	Conductor		Thickness of insulation	Thickness of inner covering	Nominal dia. over inner covering	Dia. of metal wire for braid	Thickness of outer sheath	Nominal overall dia.	Cable weight approx	Conductor resistance (20°C)	Current rating at 45°C
		Nominal sectional area	Max. overall dia.									
EA	QETH	mm ²	mm	mm	mm	mm	mm	mm	mm	kg/km	Ω /km	Amp.
1	01C025	25/9	6.6	4.5	1.6	23.3	0.3	1.2	27.7±1.1	1110	0.734	127
	01C035	35/9	7.9	4.5	1.6	24.5	0.3	1.3	29.1±1.2	1270	0.529	157
	01C050	50/10	9.1	4.5	1.7	26.0	0.3	1.3	30.6±1.2	1460	0.391	196
	01C070	70/10	11.0	4.5	1.8	28.0	0.3	1.3	32.6±1.3	1750	0.270	242
	01C095	95/12	12.9	4.5	1.8	29.9	0.3	1.4	34.7±1.4	2100	0.195	293
	01C120	120/13	14.5	4.5	1.9	31.7	0.4	1.5	37.2±1.5	2520	0.154	339
	01C150	150/16	16.2	4.5	2.0	33.4	0.4	1.5	38.9±1.6	2870	0.126	389
	01C185	185/16	18.0	4.5	2.0	35.3	0.4	1.5	40.8±1.6	3310	0.100	444
	01C240	240/18	20.6	4.5	2.1	38.1	0.4	1.6	43.8±1.8	4020	0.0762	521
	01C300	300/26	23.1	4.5	2.2	40.7	0.4	1.7	46.6±1.9	4750	0.0607	601
	01C400	400/29	26.1	4.5	2.4	44.1	0.4	1.8	50.2±2.0	5760	0.0475	710
	01C500	500/33	29.2	4.5	2.5	47.5	0.4	1.8	53.6±2.1	6880	0.0369	827
01C630	630/33	33.2	4.5	2.6	51.6	0.4	1.9	57.9±2.3	8460	0.0286	955	
3	03C025	25/16	6.6	4.5	2.6	49.3	0.4	1.9	55.6±2.2	4380	0.734	89
	03C035	35/16	7.9	4.5	2.7	52.1	0.4	2.0	58.6±2.3	5000	0.529	110
	03C050	50/25	9.1	4.5	2.8	55.1	0.4	2.0	61.6±2.5	5700	0.391	137
	03C070	70/35	11.0	4.5	2.9	59.2	0.4	2.1	65.9±2.6	6810	0.270	169
	03C095	95/50	12.9	4.5	3.1	63.6	0.4	2.2	70.5±2.8	8140	0.195	205
	03C120	120	14.5	4.5	3.2	67.3	0.4	2.3	74.4±3.0	9360	0.154	237
	03C150	150	16.2	4.5	3.4	70.9	0.4	2.4	78.2±3.1	10660	0.126	272
	03C185	185	18.0	4.5	3.6	76.8	0.4	2.6	84.2±3.4	13490	0.100	311
	03C240	240	20.6	4.5	3.8	83.0	0.4	2.7	90.6±3.6	15860	0.0762	365
	03C300	300	23.1	4.5	4.0	88.6	0.4	2.9	96.6±3.9	18320	0.0607	421
	03C120*	120/60*	14.5	4.5	3.2	67.3	0.4 ^{1/2}	2.4	76.1±3.0	10645	0.154	237
	03C150*	150/70*	16.2	4.5	3.4	70.9	0.4 ^{1/2}	2.5	79.9±3.2	12015	0.126	272
	03C185*	185/95*	18.0	4.5	3.6	76.8	0.45 ^{1/2}	2.6	86.5±3.5	14295	0.100	311
	03C240*	240/120*	20.6	4.5	3.8	83.0	0.5 ^{1/2}	2.8	93.5±3.7	17375	0.0762	365
3+E	04E025	25	6.6	4.5	2.6	49.6	0.4	1.9	55.7±2.2	4940	0.734	89
		16E	5.3	1.0							1.16	
	04E035	35	7.9	4.5	2.7	52.4	0.4	2.0	58.7±2.4	5680	0.529	110
		25E	6.6	1.2							0.734	
	04E050	50	9.1	4.5	2.8	55.3	0.4	2.0	61.6±2.5	6390	0.391	137
		25E	6.6	1.2							0.734	
	04E070	70	11.0	4.5	2.9	59.4	0.4	2.1	65.9±2.6	7620	0.270	169
		35E	7.9	1.2							0.529	
	04E095	95	12.9	4.5	3.1	64.0	0.4	2.3	70.9±2.8	9170	0.195	205
		50E	9.1	1.4							0.391	
	04E120	120	14.5	4.5	3.3	68.4	0.4	2.4	75.5±3.0	10730	0.154	237
		70E	11.0	1.4							0.270	
04E150	150	16.2	4.5	3.4	72.6	0.4	2.5	79.9±3.2	12390	0.126	272	
	95E	12.9	1.6							0.195		

Example)

8.7/15kV RFOU 1C x25mm² Part No. QETH01C025

Note) "*" double braided (option)

Q	E	T	H	01C	025
NEK606	RFOU	Flame retardant	8.7/15kV	No. of cores	Size (mm ²)

High Voltage Flame Retardant Cable

High Voltage Flame & Fire Resistant Cable

Low Voltage Flame Retardant Cable

Low Voltage Flame & Fire Resistant Cable

Technical information

12/20(24)kV Armored Flame retardant, Halogen free High voltage Power Cable (Code : 12/20kV RFOU [P112])

No. of core	Part no.	Conductor		Thickness of insulation	Thickness of inner covering	Nominal dia. over inner covering	Dia. of metal wire for braid	Thickness of outer sheath	Nominal overall dia.	Cable weight approx	Conductor resistance (20°C)	Current rating at 45°C
		Nominal sectional area	Max. overall dia.									
EA	QETJ	mm ²	mm	mm	mm	mm	mm	mm	mm	kg/km	Ω /km	Amp.
1	01C035	35/9	7.9	5.5	1.8	27.9	0.3	1.3	32.3±1.3	1630	0.529	157
	01C050	50/10	9.1	5.5	1.8	29.2	0.3	1.4	33.8±1.4	1835	0.391	196
	01C070	70/10	11.0	5.5	1.9	31.2	0.4	1.4	36.2±1.4	2235	0.270	242
	01C095	95/12	12.9	5.5	2.0	33.3	0.4	1.5	38.5±1.5	2630	0.195	293
	01C120	120/13	14.5	5.5	2.0	34.9	0.4	1.5	40.1±1.6	2960	0.154	339
	01C150	150/16	16.2	5.5	2.1	37.1	0.4	1.6	42.5±1.7	3445	0.126	389
	01C185	185/16	18.0	5.5	2.2	39.1	0.4	1.6	44.5±1.8	3925	0.100	444
	01C240	240/18	20.6	5.5	2.3	42.0	0.4	1.7	47.6±1.9	4680	0.0762	522
	01C300	300/26	23.1	5.5	2.4	44.6	0.4	1.8	50.4±2.0	5455	0.0607	601
3	03C035	35/16	7.9	5.5	2.9	57.7	0.4	2.1	64.1±2.6	5055	0.529	110
	03C050	50/25	9.1	5.5	3.0	60.7	0.4	2.2	67.3±2.7	5730	0.391	137
	03C070	70/35	11.0	5.5	3.1	64.8	0.4	2.3	71.6±2.9	6765	0.270	169
	03C095	95/50	12.9	5.5	3.3	69.3	0.4	2.4	76.3±3.1	8015	0.195	205
	03C120	120	14.5	5.5	3.4	72.9	0.4	2.5	80.1±3.2	9140	0.154	237
	03C150	150	16.2	5.5	3.6	77.6	0.4	2.6	85.0±3.4	10670	0.126	272
	03C185	185	18.0	5.5	3.8	81.9	0.4	2.7	89.5±3.6	12265	0.100	311
	03C240	240	20.6	5.5	4.0	88.1	0.4	2.9	96.1±3.8	14725	0.0762	365
	03C300	300	23.1	5.5	4.2	93.7	0.4	3.0	101.9±4.1	17190	0.0607	421
	03C120*	120/60*	14.5	5.5	3.4	72.9	0.4 ^{1/2}	2.5	81.9±3.3	11840	0.154	237
	03C150*	150/70*	16.2	5.5	3.6	77.6	0.4 ^{1/2}	2.6	86.8±3.5	13510	0.126	272
	03C185*	185/95*	18.0	5.5	3.8	81.9	0.45 ^{1/2}	2.8	92.0±3.7	15570	0.100	311
	03C240*	240/120*	20.6	5.5	4.0	88.1	0.5 ^{1/2}	2.9	98.8±4.0	18705	0.0762	365
3+3E	04E035	35	7.9	5.5	2.9	57.7	0.4	2.1	64.1±2.6	5435	0.529	110
		10E	4.2	1.0							18.20	
	045E050	50	9.1	5.5	3.0	60.7	0.4	2.2	67.3±2.7	6115	0.391	137
		10E	4.2	1.0							18.20	
	04E070	70	11.0	5.5	3.1	64.8	0.4	2.3	71.6±2.9	7330	0.270	169
		16E	5.3	1.0							1.160	
	04E095	95	12.9	5.5	3.3	69.3	0.4	2.4	76.3±3.1	8885	0.195	205
		25E	6.6	1.2							0.734	
	04E120	120	14.5	5.5	3.4	72.9	0.4	2.5	80.1±3.2	10010	0.154	237
		25E	6.6	1.2							0.734	
	04E150	150	16.2	5.5	3.6	77.6	0.4	2.6	85.0±3.4	11840	0.126	272
		35E	7.9	1.2							0.529	
	04E185	185	18.0	5.5	3.8	81.9	0.4	2.7	89.5±3.6	13440	0.100	311
		35E	7.9	1.2							0.529	
	04E240	240	20.6	5.5	4.0	88.1	0.4	2.9	96.1±3.8	16285	0.0762	365
		50E	9.1	1.4							0.3910	
	04E300	300	23.1	5.5	4.2	93.7	0.4	3.0	101.9±4.1	18750	0.0607	421
		50E	9.1	1.4							0.3910	

Example)

12/20kV RFOU 1C x35mm² Part No. QETJ01C035

Note) "*" double braided (option)

Q NEK606	E RFOU	T Flame retardant	J 12/20kV	01C No. of cores	035 Size (mm ²)
--------------------	------------------	-----------------------------	---------------------	----------------------------	---------------------------------------

HV Power cable

Armored Flame & Fire resistant, Halogen free High voltage Power Cables (HV-RFOU-Fire resistant)



Application

- Power circuit above 1kV.
- Fixed installation in both explosion risk and safe areas.
- Medium voltage power cables for emergency and critical systems.
- Maximum operating conductor temperature 90°C.

Construction Details

- 1 Conductor** : Circular tinned stranded copper as per IEC 60228, Class 2
- 2 Conductor screen** : Semi-conducting tape and/or Semi-conducting compound
- 3 Insulation** : Halogen Free Ethylene Propylene Rubber(EPR) as per IEC 60092-360
- 4 Insulation screen** : Semi-conducting compound and Semi-conducting tape
- 5 Metallic screen** : Copper(annealed or tinned) wires braid as per IEC 60092-354
- 6 Fire proof layer** : Mica glass tape and Silicon glass tape
- 7 Bedding** (with filler, binder tapes over the assembly of laid-up cores)
- 8 Bedding(Fire Block)** : Halogen-free compound
- 9 Sheath** : Flame retardant, Halogen-free thermosetting compound as per IEC 60092-360, SHF2
- 10 Armor** : Copper wires braid(screen) as per IEC 60092-354
 — RFCU-FIRE RESISTANT(option) : Galvanized steel wire braid as per IEC 60092-354
- 11 Sheath** : Halogen-free thermosetting compound as per IEC 60092-360, SHF2 or SHF2 Oil & Mud

Standard Applied

- **Design guideline** : IEC 60092-354, NEK 606
- **Material properties** : IEC 60092-360, Insulation(EPR)
IEC 60092-360, Sheath(SHF2)
- **Flame retardant** : IEC 60332-3, Cat. 'A'
- **Fire resistant** : IEC 60331-21
- **Assessment of halogen** : IEC 60754-1/2 & 60684-2
- **Low smoke properties** : IEC 61034-1/2
- **Sunlight resistance** : UL 1581
- **Cold properties(option)** : CSA C22.2 No. 03. Cold bending(-50°C), Cold impact(-50°C)
- **Oil/Mud resistance(option)** : NEK TS 606-2016 5th ed (Category a, b, c, d)

Note1)

Cross section of Armor (for 2, 3, 4 core cable)

Cross section Q of associated current carrying conductor	Min. cross section of braiding wire
$Q \leq 16\text{mm}^2$	Q
$Q > 16\text{mm}^2$	1/2 of the current-carrying conductor, but not less than 16mm ²

Approvals

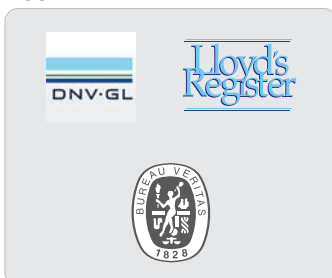

-35 to 90°C	Flame & Fire resistance IEC 60332-3 A & IEC 60331	Cold impact CSA C22.2 No.38, -65°C Special requirement	Halogen free	Weather Resistance to severe weather conditions	Chemical attacks Resistance to chemicals
Smoke-Corrosivity-Toxicity Smoke density, gases corrosivity and toxicity	Resistance to Mud NEK TS 606	Resistance to Enhanced oil & Hydraulic/gear oil			

High Voltage Flame Retardant Cable

High Voltage Flame & Fire Resistant Cable

Low Voltage Flame Retardant Cable

Low Voltage Flame & Fire Resistant Cable

Technical information

3.6/6(7.2)kV Armored Flame & Fire resistant, Halogen free High voltage Power Cable (Code : 3.6/6kV RFOU-Fire Resistant [P120])

No. of core	Part no.	Conductor		Thickness of insulation	Thickness of inner covering	Nominal dia. over inner covering	Dia. of metal wire for braid	Thickness of outer sheath	Nominal overall dia.	Cable weight approx	Conductor resistance (20°C)	Current rating at 45°C
		Nominal sectional area	Max. overall dia.									
EA	QESF	mm ²	mm	mm	mm	mm	mm	mm	mm	kg/km	Ω/km	Amp.
1	01C016	16/4	5.3	3.0	1.5	20.3	0.3	1.2	24.8±1.0	950	1.16	96
	01C025	25/9	6.6	3.0	1.6	21.8	0.3	1.2	26.3±1.1	1110	0.734	127
	01C035	35/9	7.9	3.0	1.6	23.1	0.3	1.2	27.6±1.1	1260	0.529	157
	01C050	50/10	9.1	3.0	1.7	24.4	0.3	1.3	29.1±1.2	1460	0.391	196
	01C070	70/10	11.0	3.0	1.7	26.2	0.3	1.3	30.9±1.2	1740	0.270	242
	01C095	95/12	12.9	3.0	1.8	28.3	0.3	1.4	33.2±1.3	2110	0.195	293
	01C120	120/13	14.5	3.0	1.9	30.0	0.3	1.4	34.9±1.4	2430	0.154	339
	01C150	150/16	16.2	3.0	1.9	31.6	0.4	1.4	36.9±1.5	2890	0.126	389
	01C185	185/16	18.0	3.0	2.0	33.6	0.4	1.5	39.1±1.6	3370	0.100	444
	01C240	240/18	20.6	3.0	2.1	36.5	0.4	1.6	42.2±1.7	4100	0.0762	522
	01C300	300/26	23.1	3.0	2.2	39.0	0.4	1.6	44.7±1.8	4810	0.0607	601
	01C400	400/29	26.1	3.0	2.3	42.2	0.4	1.7	48.1±1.9	5810	0.0475	719
	01C500	500/33	29.2	3.2	2.5	46.0	0.4	1.8	52.1±2.1	7030	0.0369	827
	01C630	630/33	33.2	3.2	2.6	50.2	0.4	1.9	56.5±2.3	8630	0.0286	955
3	03C016	16/16	5.3	3.0	2.3	42.3	0.4	1.7	48.2±1.9	3550	1.16	67
	03C025	25/16	6.6	3.0	2.5	45.4	0.4	1.8	51.5±2.1	4180	0.734	89
	03C035	35/16	7.9	3.0	2.6	48.4	0.4	1.9	54.7±2.2	4820	0.529	110
	03C050	50/25	9.1	3.0	2.7	51.1	0.4	1.9	57.4±2.3	5490	0.391	137
	03C070	70/35	11.0	3.0	2.8	55.1	0.4	2.0	61.6±2.5	6590	0.270	169
	03C095	95/50	12.9	3.0	3.0	59.5	0.4	2.1	66.2±2.7	7920	0.195	205
	03C120	120	14.5	3.0	3.1	63.2	0.4	2.2	70.1±2.8	9150	0.154	237
	03C150	150	16.2	3.0	3.3	66.9	0.4	2.3	74.0±3.0	10460	0.126	272
	03C185	185	18.0	3.0	3.4	71.6	0.4	2.4	78.6±3.1	12010	0.100	311
	03C240	240	20.6	3.0	3.7	78.9	0.4	2.6	86.3±3.5	14690	0.0762	365
	03C300	300	23.1	3.0	3.9	84.5	0.4	2.8	92.3±3.7	17130	0.0607	421
	03C120*	120/60*	14.5	3.0	3.1	63.2	0.4 ^{1/2}	2.3	71.8±2.9	9845	0.154	237
	03C150*	150/70*	16.2	3.0	3.3	66.9	0.4 ^{1/2}	2.4	75.7±3.0	11215	0.126	272
	03C185*	185/95*	18.0	3.0	3.4	71.6	0.45 ^{1/2}	2.5	81.1±3.2	13140	0.0762	311
03C240*	240/120*	20.6	3.0	3.7	78.9	0.5 ^{1/2}	2.7	89.2±3.6	16560	0.0607	421	
3+E	04E025	25	6.6	3.0	2.5	45.4	0.4	1.8	51.5±2.1	4260	0.734	89
		16E	5.3	1.0							1.16	
	04E035	35	7.9	3.0	2.6	48.9	0.4	1.9	55.2±2.2	5030	0.529	110
		25E	6.6	1.2							0.734	
	04E050	50	9.1	3.0	2.7	51.3	0.4	1.9	57.6±2.3	5650	0.391	137
		25E	6.6	1.2							0.734	
	04E070	70	11.0	3.0	2.8	55.6	0.4	2.0	62.1±2.5	6870	0.270	169
		35E	7.9	1.2							0.529	
	04E095	95	12.9	3.0	3.0	60.4	0.4	2.2	67.3±2.7	8390	0.195	205
		50E	9.1	1.4							0.391	
	04E120	120	14.5	3.0	3.2	64.6	0.4	2.3	71.7±2.9	9870	0.154	237
		70E	11.0	1.4							0.270	
	04E150	150	16.2	3.0	3.3	69.0	0.4	2.4	76.3±3.1	11500	0.126	272
		95E	12.9	1.6							0.195	

Note) "*" double braided (option)

Example) 3.6/6kV RFOU 1C x16mm² Part No. QEXF01C016

Q NEK606	E RFOU	S Fire resistant	F 3.6/6kV	01C No. of cores	016 Size (mm ²)
--------------------	------------------	----------------------------	---------------------	----------------------------	---------------------------------------

6/10(12)kV Armored Flame & Fire resistant, Halogen free High voltage Power Cable (Code : 6/10kV RFOU-Fire Resistant [P121])

No. of core	Part no.	Conductor		Thickness of insulation	Thickness of inner covering	Nominal dia. over inner covering	Dia. of metal wire for braid	Thickness of outer sheath	Nominal overall dia.	Cable weight approx	Conductor resistance (20°C)	Current rating at 45°C
		Nominal sectional area	Max. overall dia.									
EA	QESG	mm ²	mm	mm	mm	mm	mm	mm	mm	kg/km	Ω /km	Amp.
1	01C016	16/4	5.3	3.4	1.5	21.1	0.3	1.2	25.6±1.0	990	1.16	96
	01C025	25/9	6.6	3.4	1.6	22.6	0.3	1.2	27.1±1.1	1150	0.734	127
	01C035	35/9	7.9	3.4	1.7	24.0	0.3	1.2	28.5±1.1	1320	0.529	157
	01C050	50/10	9.1	3.4	1.7	25.2	0.3	1.3	29.9±1.2	1500	0.391	196
	01C070	70/10	11.0	3.4	1.8	27.2	0.3	1.3	31.9±1.3	1810	0.270	242
	01C095	95/12	12.9	3.4	1.8	29.1	0.3	1.4	34.0±1.4	2160	0.195	293
	01C120	120/13	14.5	3.4	1.9	30.8	0.4	1.4	36.1±1.4	2610	0.154	339
	01C150	150/16	16.2	3.4	2.0	32.6	0.4	1.5	38.1±1.5	2990	0.126	389
	01C185	185/16	18.0	3.4	2.0	34.4	0.4	1.5	39.9±1.6	3440	0.100	444
	01C240	240/18	20.6	3.4	2.2	37.4	0.4	1.6	43.1±1.7	4180	0.0762	522
	01C300	300/26	23.1	3.4	2.3	40.0	0.4	1.7	45.9±1.8	4930	0.0607	601
	01C400	400/29	26.1	3.4	2.4	43.1	0.4	1.7	49.0±2.0	5900	0.0475	719
	01C500	500/33	29.2	3.4	2.5	46.4	0.4	1.8	52.5±2.1	7070	0.0369	827
	01C630	630/33	33.2	3.4	2.7	50.7	0.4	1.9	57.0±2.3	8690	0.0286	955
3	03C016	16/16	5.3	3.4	2.4	44.1	0.4	1.8	50.2±2.0	3780	1.16	67
	03C025	25/16	6.6	3.4	2.5	47.1	0.4	1.8	53.2±2.1	4380	0.734	89
	03C035	35/16	7.9	3.4	2.6	50.1	0.4	1.9	56.4±2.3	5040	0.529	110
	03C050	50/25	9.1	3.4	2.7	52.8	0.4	2.0	59.3±2.4	5740	0.391	137
	03C070	70/35	11.0	3.4	2.9	57.0	0.4	2.1	63.7±2.6	6900	0.270	169
	03C095	95/50	12.9	3.4	3.1	61.5	0.4	2.2	68.4±2.7	8270	0.195	205
	03C120	120	14.5	3.4	3.2	65.0	0.4	2.3	72.1±2.9	9470	0.154	237
	03C150	150	16.2	3.4	3.3	68.7	0.4	2.4	76.0±3.0	10800	0.126	272
	03C185	185	18.0	3.4	3.5	73.6	0.4	2.5	80.8±3.2	12370	0.100	311
	03C240	240	20.6	3.4	3.7	80.6	0.4	2.7	88.2±3.5	10540	0.0762	365
	03C300	300	23.1	3.4	3.9	86.2	0.4	2.9	94.0±3.8	17450	0.0607	421
	03C120*	120/60*	14.5	3.4	3.2	65.0	0.4 ^{1/2}	2.3	73.6±2.9	10190	0.154	237
	03C150*	150/70*	16.2	3.4	3.3	68.7	0.4 ^{1/2}	2.4	77.5±3.1	11575	0.126	272
	03C185*	185/95*	18.0	3.4	3.5	73.6	0.45 ^{1/2}	2.5	83.1±3.3	13570	0.0762	311
03C240*	240/120*	20.6	3.4	3.7	80.6	0.5 ^{1/2}	2.7	90.9±3.6	16960	0.0607	365	
3+E	04E025	25	6.6	3.4	2.5	47.1	0.4	1.8	53.2±2.1	4470	0.734	89
		16E	5.3	1.0							1.16	
	04E035	35	7.9	3.4	2.7	50.6	0.4	1.9	56.9±2.3	5260	0.529	110
		25E	6.6	1.2							0.734	
	04E050	50	9.1	3.4	2.7	52.9	0.4	2.0	59.4±2.4	5900	0.391	137
		25E	6.6	1.2							0.734	
	04E070	70	11.0	3.4	2.9	57.3	0.4	2.1	64.0±2.6	7150	0.270	169
		35E	7.9	1.2							0.529	
	04E095	95	12.9	3.4	3.1	62.1	0.4	2.2	69.0±2.8	8660	0.195	205
		50E	9.1	1.4							0.391	
	04E120	120	14.5	3.4	3.2	66.2	0.4	2.3	73.3±2.9	10130	0.154	237
		70E	11.0	1.4							0.270	
	04E150	150	16.2	3.4	3.4	70.7	0.4	2.4	78.0±3.1	11810	0.126	272
		95E	12.9	1.6							0.195	

Example) 6/10kV RFOU 1C x16mm² Part No. QEXG01C016

Note) "*" double braided (option)

Q	E	S	G	01C	016
NEK606	BFOU	Fire resistant	6/10kV	No. of cores	Size (mm ²)

High Voltage Flame Retardant Cable

High Voltage Flame & Fire Resistant Cable

Low Voltage Flame Retardant Cable

Low Voltage Flame & Fire Resistant Cable

Technical information

LV Power cable | Unarmored Flame Retardant, Halogen free Cables (0.6/1kV RU)



Application

- Power circuit below 1kV, Lighting circuits, Trace heating circuits.
- Fixed installation power, control & lighting in safe areas, general purposes.
- Maximum operating conductor temperature 90°C

Construction Details

- 1 Conductor** : Circular tinned stranded copper as per IEC 60228 class2 or class5
- 2 Insulation** : Halogen-free Ethylene propylene rubber (EPR) as per IEC 60092-360
- 3 Core assembly** : Cabled with non-hygroscopic fillers and the binder tape may be applicable
- 4 Outer Sheath**
 - Halogen-free thermoset compound as per IEC 60092-360, SHF2 or SHF2 Oil & Mud

Standards Applied

- **Design guideline** : IEC 60092-353, NEK606
- **Material properties** : IEC 60092-360, Insulation(EPR)
IEC 60092-360, Sheath(SHF2)
- **Flame retardant** : IEC 60332-3, Cat. 'A'
- **Assessment of halogen** : IEC 60754-1/2 & 60684-2
- **Low smoke properties** : IEC 61034-1/2
- **Sunlight resistance** : UL 1581
- **Cold properties(option)** : CSA C22.2 No. 03. Cold bending(-50°C), Cold impact(-50°C)
- **Oil/Mud resistance(option)** : NEK TS 606 5th ed (Category a, b, c, d)

Identification of color

- **Insulation** :
 - 1C : Grey (off-white)
 - 2C : Grey, Black
 - 3C : Grey, Black, Red
 - 4C : Grey, Black, Red, Blue
 - 5Core and above : By numbering on White colored insulation
 - Earth core : Green/Yellow stripe
 - **Outer sheath** : Black
- Note) The any other identification of color may be applicable when purchaser required

Approvals

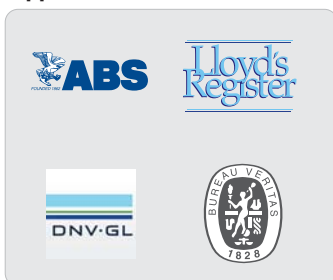

-35 to 90°C



Flame retardant
IEC 60332-3, A



Cold impact
CSA C22.2 No.38, -65°C
Special requirement



Halogen free



Weather
Resistance to severe
weather conditions



Chemical attacks
Resistance to
chemicals



Smoke-Corrosivity-Toxicity
Smoke density, gases corrosivity and toxicity

0.6/1kV Unarmored Flame retardant, Halogen free Cable (Code : 0.6/1kV RU [P111])

No. of core	Part no.	Conductor		Thickness of insulation	Thickness of outer sheath	Nominal overall dia.	Cable weight approx.	Conductor resistance (20°C)	Current rating at 45°C
		Nominal sectional area	Max. overall dia.						
EA	QCTD	mm ²	mm	mm	mm	mm	kg/km	Ω /km	Amp.
1	01C001	1.0	1.4	1.0	1.0	5.3±0.6	45	18.2	18
	01C015	1.5	1.7	1.0	1.0	5.6±0.6	55	12.2	23
	01C025	2.5	2.2	1.0	1.0	6.0±0.6	65	7.56	30
	01C004	4	2.7	1.0	1.0	6.5±0.6	85	4.70	40
	01C006	6	3.3	1.0	1.0	7.1±0.6	105	3.11	52
	01C010	10	4.2	1.0	1.0	8.0±0.6	150	1.84	72
	01C016	16	5.3	1.0	1.1	9.2±0.6	220	1.16	96
	01C025	25	6.6	1.2	1.1	10.9±0.6	330	0.734	127
	01C035	35	7.9	1.2	1.2	12.2±0.6	430	0.529	157
	01C050	50	9.1	1.4	1.3	14.3±0.6	585	0.391	196
	01C070	70	11.0	1.4	1.3	16.0±0.6	790	0.270	242
	01C095	95	12.9	1.6	1.4	18.4±0.7	1065	0.195	293
	01C120	120	14.5	1.6	1.5	20.3±0.8	1340	0.154	339
	01C150	150	16.2	1.8	1.6	22.5±0.9	1650	0.126	389
	01C185	185	18.0	2.0	1.7	24.7±1.0	2000	0.1000	444
01C240	240	20.6	2.2	1.8	28.2±1.1	2650	0.0762	522	
01C300	300	23.1	2.4	1.9	30.9±1.2	3215	0.0607	601	
2	02C001	1.0	1.4	1.0	1.1	9.0±0.6	100	18.2	15
	02C015	1.5	1.7	1.0	1.1	9.6±0.6	120	12.2	20
	02C025	2.5	2.2	1.0	1.1	10.4±0.6	145	7.56	26
	02C004	4	2.7	1.0	1.2	11.6±0.6	190	4.70	34
	02C006	6	3.3	1.0	1.2	12.8±0.6	250	3.11	44
	02C010	10	4.2	1.0	1.3	14.8±0.6	360	1.84	61
	02C016	16	5.3	1.0	1.4	17.0±0.7	515	1.16	82
	02C025	25	6.6	1.2	1.5	20.6±0.8	775	0.734	108
	02C035	35	7.9	1.2	1.6	23.0±0.9	1010	0.529	133
	02C050	50	9.1	1.4	1.7	27.0±1.1	1370	0.391	167
	02C070	70	11.0	1.4	1.9	30.8±1.2	1875	0.270	206
	02C095	95	12.9	1.6	2.1	35.6±1.4	2515	0.195	249
	02C120	120	14.5	1.6	2.2	39.2±1.6	3140	0.154	288
	02C150	150	16.2	1.8	2.4	43.6±1.7	3880	0.126	331
	02C185	185	18.0	2.0	2.5	47.8±1.9	4695	0.1000	377
02C240	240	20.6	2.2	2.8	55.0±2.2	6255	0.0762	444	
02C300	300	23.1	2.4	3.0	60.4±2.4	7585	0.0607	511	

Example)

0.6/1kV RU 2C x1.5mm² Part No. QCTD02C015

Q NEK606	C RU	T Flame retardant	D 0.6/1kV	02C No. of cores	015 Size (mm ²)
--------------------	----------------	-----------------------------	---------------------	----------------------------	---------------------------------------

High Voltage Flame Retardant Cable

High Voltage Flame & Fire Resistant Cable

Low Voltage Flame Retardant Cable

Low Voltage Flame & Fire Resistant Cable

Technical information

0.6/1kV Unarmored Flame retardant, Halogen free Cable (Code : 0.6/1kV RU [P111])

No. of core	Part no.	Conductor		Thickness of insulation	Thickness of outer sheath	Nominal overall dia.	Cable weight approx.	Conductor resistance (20°C)	Current rating at 45°C
		Nominal sectional area	Max. overall dia.						
EA	QCTD	mm ²	mm	mm	mm	mm	kg/km	Ω /km	Amp.
3	03C001	1.0	1.4	1.0	1.1	9.5±0.6	120	18.2	12
	03C015	1.5	1.7	1.0	1.1	10.2±0.6	145	12.2	16
	03C025	2.5	2.2	1.0	1.2	11.2±0.6	185	7.56	21
	03C004	4	2.7	1.0	1.2	12.3±0.6	245	4.70	28
	03C006	6	3.3	1.0	1.2	13.6±0.6	325	3.11	36
	03C010	10	4.2	1.0	1.3	15.7±0.6	475	1.84	50
	03C016	16	5.3	1.0	1.4	18.1±0.7	685	1.16	67
	03C025	25	6.6	1.2	1.6	22.1±0.9	1060	0.734	89
	03C035	35	7.9	1.2	1.7	24.7±1.0	1380	0.529	110
	03C050	50	9.1	1.4	1.8	29.0±1.2	1875	0.391	137
	03C070	70	11.0	1.4	2.0	33.1±1.3	2580	0.270	169
	03C095	95	12.9	1.6	2.2	38.2±1.5	3470	0.195	205
	03C120	120	14.5	1.6	2.3	42.1±1.7	4345	0.154	237
	03C150	150	16.2	1.8	2.5	46.8±1.9	5370	0.126	272
	03C185	185	18.0	2.0	2.6	51.3±2.1	6505	0.1000	311
03C240	240	20.6	2.2	2.9	59.0±2.4	8680	0.0762	365	
03C300	300	23.1	2.4	3.1	64.8±2.6	10540	0.0607	421	
4	04C001	1.0	1.4	1.0	1.1	10.4±0.6	145	18.2	12
	04C015	1.5	1.7	1.0	1.2	11.3±0.6	180	12.2	16
	04C025	2.5	2.2	1.0	1.2	12.3±0.6	230	7.56	21
	04C004	4	2.7	1.0	1.2	13.5±0.6	305	4.70	28
	04C006	6	3.3	1.0	1.3	15.1±0.6	415	3.11	36
	04C010	10	4.2	1.0	1.4	17.5±0.7	610	1.84	50
	04C016	16	5.3	1.0	1.5	20.1±0.8	885	1.16	67
	04C025	25	6.6	1.2	1.6	24.4±1.0	1355	0.734	89
	04C035	35	7.9	1.2	1.8	27.5±1.1	1785	0.529	110
	04C050	50	9.1	1.4	1.9	32.2±1.3	2430	0.391	137
	04C070	70	11.0	1.4	2.1	36.7±1.5	3350	0.270	169
	04C095	95	12.9	1.6	2.3	42.5±1.7	4510	0.195	205
	04C120	120	14.5	1.6	2.5	47.0±1.9	5675	0.154	237
	04C150	150	16.2	1.8	2.7	52.2±2.1	7015	0.126	272
	04C185	185	18.0	2.0	2.9	57.4±2.3	8530	0.1000	311
04C240	240	20.6	2.2	3.2	66.0±2.6	11380	0.0762	365	
04C300	300	23.1	2.4	3.4	72.4±2.9	13810	0.0607	421	

Example)

0.6/1kV RU 3C x1.5mm² Part No. QCTD03C015

Q NEK606	C RU	T Flame retardant	D 0.6/1kV	03C No. of cores	015 Size (mm ²)
--------------------	----------------	-----------------------------	---------------------	----------------------------	---------------------------------------

0.6/1kV Unarmored Flame retardant, Halogen free Cable (Code : 0.6/1kV RU [P111])

No. of core	Part no.	Conductor		Thickness of insulation	Thickness of outer sheath	Nominal overall dia.	Cable weight approx.	Conductor resistance (20°C)	Current rating at 45°C
		Nominal sectional area	Max. overall dia.						
EA	QCTD	mm ²	mm	mm	mm	mm	kg/km	Ω /km	Amp.
5	05C001	1.0	1.4	1.0	1.2	11.5±0.6	175	18.2	10
6	06C001	1.0	1.4	1.0	1.2	12.5±0.6	205	18.2	9
7	07C001	1.0	1.4	1.0	1.2	12.5±0.6	215	18.2	9
8	08C001	1.0	1.4	1.0	1.2	13.5±0.6	250	18.2	9
9	09C001	1.0	1.4	1.0	1.3	14.7±0.6	285	18.2	8
10	10C001	1.0	1.4	1.0	1.3	16.0±0.6	305	18.2	8
12	12C001	1.0	1.4	1.0	1.4	16.7±0.7	355	18.2	7
14	14C001	1.0	1.4	1.0	1.4	17.6±0.7	400	18.2	7
16	16C001	1.0	1.4	1.0	1.4	18.5±0.7	445	18.2	7
19	19C001	1.0	1.4	1.0	1.5	19.7±0.8	510	18.2	6
20	20C001	1.0	1.4	1.0	1.5	20.2±0.8	550	18.2	6
23	23C001	1.0	1.4	1.0	1.5	21.7±0.8	615	18.2	6
24	24C001	1.0	1.4	1.0	1.6	23.2±0.9	650	18.2	6
27	27C001	1.0	1.4	1.0	1.6	23.7±0.9	710	18.2	6
30	30C001	1.0	1.4	1.0	1.7	24.8±1.9	785	18.2	5
33	33C001	1.0	1.4	1.0	1.7	25.7±1.0	855	18.2	5
37	37C001	1.0	1.4	1.0	1.7	26.7±1.1	930	18.2	5
44	44C001	1.0	1.4	1.0	1.9	30.4±1.2	1130	18.2	5
5	05C015	1.5	1.7	1.0	1.2	12.3±0.5	215	12.2	13
6	06C015	1.5	1.7	1.0	1.2	13.4±0.6	250	12.2	12
7	07C015	1.5	1.7	1.0	1.2	13.4±0.6	270	12.2	12
8	08C015	1.5	1.7	1.0	1.3	14.7±0.7	320	12.2	11
9	09C015	1.5	1.7	1.0	1.3	15.8±0.7	360	12.2	11
10	10C015	1.5	1.7	1.0	1.4	17.4±0.7	390	12.2	10
12	12C015	1.5	1.7	1.0	1.4	18.0±0.8	440	12.2	10
14	14C015	1.5	1.7	1.0	1.4	18.9±0.8	500	12.2	9
16	16C015	1.5	1.7	1.0	1.5	20.1±0.9	570	12.2	9
19	19C015	1.5	1.7	1.0	1.5	21.2±0.9	635	12.2	8
20	20C015	1.5	1.7	1.0	1.6	22.0±1.0	695	12.2	8
23	23C015	1.5	1.7	1.0	1.6	23.6±1.0	785	12.2	8
24	24C015	1.5	1.7	1.0	1.7	25.2±1.1	825	12.2	7
27	27C015	1.5	1.7	1.0	1.7	25.8±1.1	905	12.2	7
30	30C015	1.5	1.7	1.0	1.7	26.7±1.1	995	12.2	7
33	33C015	1.5	1.7	1.0	1.8	27.9±1.2	1095	12.2	7
37	37C015	1.5	1.7	1.0	1.8	29.0±1.2	1190	12.2	6
44	44C015	1.5	1.7	1.0	2.0	33.0±1.4	1445	12.2	6

Example) 0.6/1kV RU 5C x1.5mm² Part No. QCTD05C015

Q NEK606	C RU	T Flame retardant	D 0.6/1kV	05C No. of cores	015 Size (mm ²)
--------------------	----------------	-----------------------------	---------------------	----------------------------	---------------------------------------

High Voltage Flame Retardant Cable

High Voltage Flame & Fire Resistant Cable

Low Voltage Flame Retardant Cable

Low Voltage Flame & Fire Resistant Cable

Technical information

0.6/1kV Unarmored Flame retardant, Halogen free Cable (Code : 0.6/1kV RU [P111])

No. of core	Part no.	Conductor		Thickness of insulation	Thickness of outer sheath	Nominal overall dia.	Cable weight approx.	Conductor resistance (20°C)	Current rating at 45°C
		Nominal sectional area	Max. overall dia.						
EA	QCTD	mm ²	mm	mm	mm	mm	kg/km	Ω /km	Amp.
5	05C025	2.5	2.2	1.0	1.2	13.4±0.6	275	7.56	17
6	06C025	2.5	2.2	1.0	1.3	14.8±0.6	335	7.56	16
7	07C025	2.5	2.2	1.0	1.3	14.8±0.6	360	7.56	15
8	08C025	2.5	2.2	1.0	1.3	16.0±0.6	415	7.56	15
9	09C025	2.5	2.2	1.0	1.4	17.5±0.7	475	7.56	14
10	10C025	2.5	2.2	1.0	1.4	19.0±0.8	505	7.56	13
12	12C025	2.5	2.2	1.0	1.5	19.8±0.8	585	7.56	13
14	14C025	2.5	2.2	1.0	1.5	20.9±0.8	670	7.56	12
16	16C025	2.5	2.2	1.0	1.6	22.2±0.9	760	7.56	11
19	19C025	2.5	2.2	1.0	1.6	23.4±0.9	860	7.56	11
20	20C025	2.5	2.2	1.0	1.6	24.1±1.0	930	7.56	11
23	23C025	2.5	2.2	1.0	1.7	26.1±1.0	1060	7.56	10
24	24C025	2.5	2.2	1.0	1.8	27.8±1.1	1115	7.56	10
27	27C025	2.5	2.2	1.0	1.8	28.4±1.1	1225	7.56	10
30	30C025	2.5	2.2	1.0	1.8	29.5±1.2	1340	7.56	9
33	33C025	2.5	2.2	1.0	1.9	30.8±1.2	1475	7.56	9
37	37C025	2.5	2.2	1.0	1.9	32.0±1.3	1610	7.56	9
44	44C025	2.5	2.2	1.0	2.1	36.4±1.5	1945	7.56	8

Example) 0.6/1kV RU 5C x2.5mm² Part No. QCTD05C025

Q	C	T	D	05C	025
NEK606	RU	Flame retardant	0.6/1kV	No. of cores	Size (mm ²)

LV Power cable

Armored Flame Retardant, Halogen free Cables (0.6/1kV RFOU) Armored Flame & Fire Resistant, Halogen free Cables (0.6/1kV SFOU)

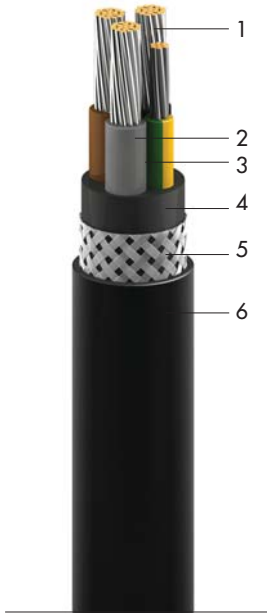

Application

- Power circuit below 1kV, Lighting circuits, Trace heating circuits.
- Fixed installation power, control & lighting in both explosion risk and safe areas, general purposes.
- Maximum operating conductor temperature 90°C

Construction Details

- 1 Conductor** : Circular tinned stranded copper as per IEC 60228 Class 2 or Class 5
- 2 Insulation** : Halogen-free Ethylene propylene rubber (EPR-RFOU) or Silicone rubber(S95-SFOU) as per IEC 60092-360
- 3 Core assembly** : Cabled with non-hygroscopic fillers and the binder tape may be applicable
- 4 Bedding** : Halogen-free compound(Inner covering)
- 5 Armor** : Copper wires braid(screen)¹ as per IEC 60092-353
– RFCU(option) : Galvanized steel wire braid as per IEC 60092-353
- 6 Outer Sheath** : Halogen-free thermosetting compound as per IEC 60092-360, SHF2 or SHF2 Oil & Mud

Standards Applied

- **Design guideline** : IEC 60092-353, NEK606
- **Material properties** : IEC 60092-360, Insulation (EPR, S95)
IEC 60092-360, Sheath (SHF2)
- **Flame retardant** : IEC 60332-3, Cat. 'A'
- **Fire resistant(SFOU)**: IEC 60331-1/2 at 830°C for 120 min.
(option) waterspray for 15min
- **Assessment of halogen** : IEC 60754-1/2 & 60684-2
- **Low smoke properties** : IEC 61034-1/2
- **Sunlight resistance** : UL 1581
- **Cold properties(option)** : CSA C22.2 No. 03. Cold bending(-50°C), Cold impact(-50°C)
- **Oil/Mud resistance(option)** : NEK TS 606 5th ed (Category a, b, c, d)

Identification of color

- **Insulation** : -1C : Grey (off-white)
-2C : Grey, Black
-3C : Grey, Black, Red
-4C : Grey, Black, Red, Blue
-5Core and above : By numbering on White colored insulation
-Earth core : Green/Yellow stripe

- **Outer sheath** : Black

Note) The any other identification of color may be applicable when purchaser required



-35 to 90°C



Flame & Fire resistant
IEC 60332-3 A
& IEC 60331(SFOU)



Cold impact
CSA C22.2 No.38, -65°C
Special requirement



Halogen free



Weather
Resistance to severe
weather conditions



Chemical attacks
Resistance to
chemicals



Smoke-Corrosivity-Toxicity
Smoke density, gases corrosivity and toxicity



Resistance to Mud
NEK TS 606



Resistance to
Enhanced oil &
Hydraulic/gear oil

Note1)

Cross section of Armor (for 2, 3, 4 core cable)

Cross section Q of associated current carrying conductor	Min. cross section of braiding wire
$Q \leq 16\text{mm}^2$	Q
$Q > 16\text{mm}^2$	1/2 of the current-carrying conductor, but not less than 16mm^2

Approvals

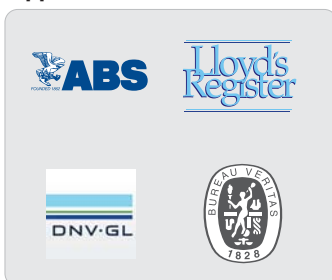

Resistance to
Enhanced oil &
Hydraulic/gear oil

High Voltage Flame Retardant Cable

High Voltage Flame & Fire Resistant Cable

Low Voltage Flame Retardant Cable

Low Voltage Flame & Fire Resistant Cable

Technical information

0.6/1kV Armored Flame retardant, Halogen free Cable (Code 0.6/1kV RFOU [P101])
0.6/1kV Armored Flame & Fire resistant, Halogen free Cable (Code 0.6/1kV SFOU [P125])

No. of core	Part no.	Conductor		Thickness of insulation	Thickness of inner covering	Nominal dia. over inner covering	Dia. of metal wire for braid	Thickness of outer sheath	Nominal overall dia.	Cable weight approx	Conductor resistance (20°C)	Current rating at 45°C
		Nominal sectional area	Max. overall dia.									
EA	QETD/QESD	mm ²	mm	mm	mm	mm	mm	mm	mm	kg/km	Ω/km	Amp.
1	01C001	1.0/3	1.4	1.0	1.0	4.9	0.2	1.0	7.8±0.6	100	18.2	18
	01C015	1.5/3	1.7	1.0	1.0	5.2	0.2	1.0	8.1±0.6	110	12.2	23
	01C025	2.5/3	2.2	1.0	1.0	5.6	0.2	1.1	8.7±0.6	130	7.56	30
	01C004	4/3	2.7	1.0	1.0	6.1	0.2	1.1	9.2±0.6	150	4.70	40
	01C006	6/3	3.3	1.0	1.0	6.7	0.2	1.1	9.8±0.6	180	3.11	52
	01C010	10/3	4.2	1.0	1.0	7.6	0.2	1.1	10.7±0.6	235	1.84	72
	01C016	16/4	5.3	1.0	1.0	8.6	0.2	1.2	11.9±0.6	315	1.16	96
	01C025	25/9	6.6	1.2	1.0	10.3	0.3	1.3	14.3±0.6	480	0.734	127
	01C035	35/9	7.9	1.2	1.0	11.4	0.3	1.3	15.4±0.6	590	0.529	157
	01C050	50/10	9.1	1.4	1.0	13.3	0.3	1.4	17.5±0.7	765	0.391	196
	01C070	70/10	11.0	1.4	1.0	15.0	0.3	1.5	19.4±0.8	1010	0.270	242
	01C095	95/12	12.9	1.6	1.0	17.2	0.3	1.5	21.6±0.9	1295	0.195	293
	01C120	120/13	14.5	1.6	1.0	18.9	0.3	1.6	23.5±0.9	1590	0.154	339
	01C150	150/16	16.2	1.8	1.0	20.9	0.3	1.7	25.7±1.0	1925	0.126	389
	01C185	185/16	18.0	2.0	1.0	22.9	0.3	1.8	27.9±1.1	2300	0.1000	444
01C240	240/18	20.6	2.2	1.2	26.2	0.3	1.9	31.4±1.3	2995	0.0762	522	
01C300	300/26	23.1	2.4	1.2	29.0	0.3	2.0	34.4±1.4	3615	0.0607	601	
2	02C001	1.0/3	1.4	1.0	1.0	8.4	0.2	1.2	11.7±0.6	190	18.2	15
	02C015	1.5/4	1.7	1.0	1.0	9.0	0.2	1.2	12.3±0.6	215	12.2	20
	02C025	2.5/6	2.2	1.0	1.0	9.8	0.2	1.2	13.1±0.6	250	7.56	26
	02C004	4/6	2.7	1.0	1.0	10.8	0.3	1.3	14.8±0.6	350	4.70	34
	02C006	6/6	3.3	1.0	1.0	12.0	0.3	1.3	16.0±0.6	420	3.11	44
	02C010	10/10	4.2	1.0	1.0	13.8	0.3	1.4	18.0±1.4	550	1.84	61
	02C016	16/16	5.3	1.0	1.0	15.8	0.3	1.5	20.2±1.6	725	1.16	82
	02C025	25/16	6.6	1.2	1.0	19.2	0.3	1.6	23.8±1.7	1035	0.734	108
	02C035	35/16	7.9	1.2	1.0	21.4	0.3	1.7	26.2±1.9	1290	0.529	133
	02C050	50/25	9.1	1.4	1.0	25.2	0.3	1.9	30.4±2.1	1715	0.391	167
	02C070	70/35	11.0	1.4	1.2	28.9	0.3	2.0	34.3±2.4	2275	0.270	206
	02C095	95/50	12.9	1.6	1.2	33.3	0.4	2.2	39.5±2.6	3055	0.195	249
	02C120	120	14.5	1.6	1.2	36.7	0.4	2.3	43.1±1.6	3730	0.154	288
	02C150	150	16.2	1.8	1.4	41.0	0.4	2.5	47.8±1.7	4570	0.126	331
	02C185	185	18.0	2.0	1.4	45.0	0.4	2.7	52.2±1.9	5470	0.1000	377
	02C240	240	20.6	2.2	1.6	52.0	0.4	3.0	59.8±2.1	7205	0.0762	444
	02C300	300	23.1	2.4	1.6	57.0	0.4	3.2	65.2±2.4	8625	0.0607	511
	02C120*	120/60*	14.5	1.6	1.2	36.7	*0.4 ^{1/2}	2.4	45.1±2.6	4190	0.154	288
	02C150*	150/75*	16.2	1.8	1.4	41.0	*0.4 ^{1/2}	2.6	49.8±2.0	5080	0.126	331
	02C185*	185/95*	18.0	2.0	1.4	45.0	*0.45 ^{1/2}	2.8	54.7±2.2	6170	0.1000	377
02C240*	240/120*	20.6	2.2	1.6	52.0	*0.5 ^{1/2}	3.1	62.7±2.5	8140	0.0762	444	

Example) 0.6/1kV RFOU 2C x2.5mm² Part No. QETD02C025

Note) "*" double braided : (option)

Q NEK606	E RFOU	T Flame retardant	D 0.6/1kV	02C No. of cores	025 Size (mm ²)
--------------------	------------------	-----------------------------	---------------------	----------------------------	---------------------------------------

0.6/1kV Armored Flame retardant, Halogen free Cable (Code 0.6/1kV RFOU [P101])
0.6/1kV Armored Flame & Fire Resistant, Halogen free Cable (Code 0.6/1kV SFOU [P125])

No. of core	Part no.	Conductor		Thickness of insulation	Thickness of inner covering	Nominal dia. over inner covering	Dia. of metal wire for braid	Thickness of outer sheath	Nominal overall dia.	Cable weight approx	Conductor resistance (20°C)	Current rating at 45°C
		Nominal sectional area	Max. overall dia.									
EA	QETD/QESD	mm ²	mm	mm	mm	mm	mm	mm	mm	kg/km	Ω /km	Amp.
2+E	03E025	25 16E	6.6 5.3	1.2 1.0	1.0	20.2	0.3	1.7	25.0±1.0	1245	0.734 1.16	108
	03E035	35 25E	7.9 6.6	1.2 1.2	1.0	22.7	0.3	1.8	27.7±1.1	1610	0.529 0.734	133
	03E050	50 25E	9.1 6.6	1.4 1.2	1.0	26.4	0.3	1.9	31.6±1.3	2020	0.391 0.734	167
	03E070	70 35E	11.0 7.9	1.4 1.2	1.2	30.3	0.4	2.1	36.3±1.5	2770	0.270 0.529	206
	03E095	95 50E	12.9 9.1	1.6 1.4	1.2	35.0	0.4	2.3	41.4±1.7	3630	0.195 0.391	249
	03E120	120 70E	14.5 11.0	1.6 1.4	1.4	38.9	0.4	2.4	45.5±1.8	4550	0.154 0.270	288
	03E150	150 95E	16.2 12.9	1.8 1.6	1.4	43.3	0.4	2.6	50.3±2.0	5625	0.126 0.195	331
	03E185	185 95E	18.0 12.9	2.0 1.6	1.4	47.2	0.4	2.8	54.6±2.2	6530	0.100 0.195	377
3	03C001	1.0/3	1.4	1.0	1.0	8.9	0.2	1.2	12.2±0.6	215	18.2	12
	03C015	1.5/4	1.7	1.0	1.0	9.6	0.2	1.2	12.9±0.6	245	12.2	16
	03C025	2.5/6	2.2	1.0	1.0	10.4	0.3	1.3	14.4±0.6	335	7.56	21
	03C004	4/6	2.7	1.0	1.0	11.5	0.3	1.3	15.5±0.6	410	4.70	28
	03C006	6/6	3.3	1.0	1.0	12.8	0.3	1.4	17.0±0.7	510	3.11	36
	03C010	10/10	4.2	1.0	1.0	14.7	0.3	1.4	18.9±0.8	670	1.84	50
	03C016	16/16	5.3	1.0	1.0	16.9	0.3	1.5	21.3±0.9	910	1.16	67
	03C025	25/16	6.6	1.2	1.0	20.5	0.3	1.7	25.3±1.0	1330	0.734	89
	03C035	35/16	7.9	1.2	1.0	22.9	0.3	1.8	27.9±1.1	1680	0.529	110
	03C050	50/25	9.1	1.4	1.2	27.3	0.3	1.9	32.5±1.3	2250	0.391	137
	03C070	70/35	11.0	1.4	1.2	31.0	0.4	2.1	37.0±1.5	3085	0.270	169
	03C095	95/50	12.9	1.6	1.2	35.7	0.4	2.3	42.1±1.7	4045	0.195	205
	03C120	120	14.5	1.6	1.4	39.7	0.4	2.5	46.5±1.9	5035	0.154	237
	03C150	150	16.2	1.8	1.4	44.0	0.4	2.6	51.0±2.0	6110	0.126	272
	03C185	185	18.0	2.0	1.6	48.7	0.4	2.8	56.1±2.2	7395	0.1000	311
	03C240	240	20.6	2.2	1.6	55.8	0.4	3.1	63.8±2.6	9695	0.076	365
	03C300	300	23.1	2.4	1.6	61.2	0.4	3.3	69.6±2.8	11650	0.0607	421
	03C120*	120/60*	14.5	1.6	1.4	39.7	*0.4 ^{1/2}	2.5	48.3±1.9	5510	0.154	237
	03C150*	150/70*	16.2	1.8	1.4	44.0	*0.4 ^{1/2}	2.7	53.0±2.1	6660	0.126	272
	03C185*	185/95*	18.0	2.0	1.6	48.7	*0.45 ^{1/2}	2.9	58.6±2.3	8155	0.1000	311
03C240*	240/120*	20.6	2.2	1.6	55.8	*0.5 ^{1/2}	3.2	66.7±2.7	10705	0.076	365	
3+E	04E025	25 16E	6.6 5.3	1.2 1.0	1.0	21.9	0.3	1.7	26.7±1.1	1530	0.734 1.16	89
	04E035	35 25E	7.9 6.6	1.2 1.2	1.0	24.9	0.3	1.9	30.1±1.2	2005	0.529 0.734	110
	04E050	50 25E	9.1 6.6	1.4 1.2	1.2	28.8	0.3	2.0	34.2±1.4	2565	0.391 0.734	137
	04E070	70 35E	11.0 7.9	1.4 1.2	1.2	32.6	0.4	2.2	38.8±1.6	3500	0.270 0.529	169
	04E095	95 50E	12.9 9.1	1.6 1.4	1.4	38.1	0.4	2.4	44.7±1.8	4645	0.195 0.391	205
	04E120	120 70E	14.5 11.0	1.6 1.4	1.4	42.2	0.4	2.6	49.2±2.0	5815	0.154 0.270	237
	04E150	150 95E	16.2 12.9	1.8 1.6	1.4	46.0	0.4	2.7	53.2±2.1	6880	0.126 0.195	272
	04E185	185 95E	18.0 12.9	2.0 1.6	1.6	51.4	0.4	2.9	59.0±2.4	8435	0.100 0.195	311

Example) 0.6/1kV SFOU 3C x1.5mm² Part No. QESD03C015

Note) "*" double braided : (option)

Q	E	S	D	03C	015
NEK606	SFOU	Fire resistant (SR)	0.6/1kV	No. of cores	Size (mm ²)

High Voltage Flame Retardant Cable
 High Voltage Flame & Fire Resistant Cable
 Low Voltage Flame Retardant Cable
 Low Voltage Flame & Fire Resistant Cable
 Technical information

0.6/1kV Armored Flame retardant, Halogen free Cable (Code 0.6/1kV RFOU [P101])
0.6/1kV Armored Flame & Fire resistant, Halogen free Cable (Code 0.6/1kV RFOU [P125])

No. of core	Part no.	Conductor		Thickness of insulation	Thickness of inner covering	Nominal dia. over inner covering	Dia. of metal wire for braid	Thickness of outer sheath	Nominal overall dia.	Cable weight approx	Conductor resistance (20°C)	Current rating at 45°C
		Nominal sectional area	Max. overall dia.									
EA	QETD/QESD	mm ²	mm	mm	mm	mm	mm	mm	mm	kg/km	Ω/km	Amp.
4	04C001	1.0/3	1.4	1.0	1.0	9.8	0.2	1.2	13.1±0.6	250	18.2	12
	04C015	1.5/4	1.7	1.0	1.0	10.5	0.3	1.3	14.5±0.6	330	12.2	16
	04C025	2.5/6	2.2	1.0	1.0	11.5	0.3	1.3	15.5±0.6	395	7.56	21
	04C004	4/6	2.7	1.0	1.0	12.7	0.3	1.4	16.9±0.7	490	4.70	28
	04C006	6/6	3.3	1.0	1.0	14.1	0.3	1.4	18.3±0.7	605	3.11	36
	04C010	10/10	4.2	1.0	1.0	16.3	0.3	1.5	20.7±0.8	825	1.84	50
	04C016	16/16	5.3	1.0	1.0	18.7	0.3	1.6	23.3±0.9	1140	1.16	67
	04C025	25/16	6.6	1.2	1.0	22.8	0.3	1.8	27.8±1.1	1670	0.734	89
	04C035	35/16	7.9	1.2	1.0	25.5	0.3	1.9	30.7±1.2	2120	0.529	110
	04C050	50/25	9.1	1.4	1.2	30.3	0.4	2.1	36.3±1.5	2940	0.391	137
	04C070	70/35	11.0	1.4	1.2	34.4	0.4	2.3	40.6±1.6	3905	0.270	169
	04C095	95/50	12.9	1.6	1.4	40.1	0.4	2.5	46.9±1.9	5205	0.195	205
	04C120	120	14.5	1.6	1.4	44.2	0.4	2.6	51.2±2.0	6420	0.154	237
	04C150	150	16.2	1.8	1.6	49.4	0.4	2.8	56.8±2.3	7890	0.126	272
	04C185	185	18.0	2.0	1.6	54.2	0.4	3.0	62.0±2.5	9490	0.100	311
	04C240	240	20.6	2.2	1.6	62.2	0.4	3.4	70.8±2.8	12505	0.0762	365
	04C300	300	23.1	2.4	1.8	68.5	0.4	3.6	77.5±3.1	15100	0.0607	421
	04C120*	120/60*	14.5	1.6	1.4	44.2	*0.4 ^{1/2}	2.7	53.2±2.1	6940	0.154	237
	04C150*	150/70*	16.2	1.8	1.6	49.4	*0.4 ^{1/2}	2.9	58.8±2.4	8465	0.126	272
	04C185*	185/95*	18.0	2.0	1.6	54.2	*0.4 ^{1/2}	3.1	64.5±2.6	10285	0.1000	311
04C240*	240/120*	20.6	2.2	1.6	62.2	*0.4 ^{1/2}	3.4	73.7±2.9	13570	0.076	365	
4+E	05E025	25	6.6	1.2	1.0	25.0	0.3	1.9	30.2±1.2	1900	0.734	89
		16E	5.3	1.0							1.16	
	05E035	35	7.9	1.2	1.2	28.4	0.3	2.0	33.8±1.4	2480	0.529	110
		25E	6.6	1.2							0.734	
	05E050	50	9.1	1.4	1.2	33.0	0.4	2.2	39.2±1.6	3290	0.391	137
		25E	6.6	1.2							0.734	
	05E070	70	11.0	1.6	1.4	37.8	0.4	2.4	44.4±1.8	4415	0.270	169
		35E	7.9	1.4							0.529	
	05E095	95	12.9	1.6	1.4	43.7	0.4	2.6	50.7±2.0	5820	0.195	205
		50E	9.1	1.4							0.391	
	05E120	120	14.5	1.8	1.6	48.7	0.4	2.8	56.1±2.2	7330	0.154	237
		70E	11.0	1.6							0.270	
	05E150	150	16.2	2.0	1.6	54.2	0.4	3.0	62.0±2.5	9030	0.126	272
		95E	12.9	1.6							0.195	
	05E185	185	18.0	2.0	1.6	59.1	0.4	3.2	67.3±2.7	10640	0.100	311
		95E	12.9	1.6							0.195	

Example) 0.6/1kV RFOU 4C x16mm² Part No. QETD04C016

Note) "*" double braided : (option)

Q NEK606	E RFOU	T Flame retardant	D 0.6/1kV	04C No. of cores	016 Size (mm ²)
--------------------	------------------	-----------------------------	---------------------	----------------------------	---------------------------------------

0.6/1kV Armored Flame retardant, Halogen free Cable (Code 0.6/1kV RFOU [P101])
0.6/1kV Armored Flame & Fire Resistant, Halogen free Cable (Code 0.6/1kV SFOU [P125])

No. of core	Part no.	Conductor		Thickness of insulation	Thickness of inner covering	Nominal dia. over inner covering	Dia. of metal wire for braid	Thickness of outer sheath	Nominal overall dia.	Cable weight approx	Conductor resistance (20°C)	Current rating at 45°C
		Nominal sectional area	Max. overall dia.									
EA	QETD/QESD	mm ²	mm	mm	mm	mm	mm	mm	mm	kg/km	Ω /km	Amp.
5	05C001	1.0	1.4	1.0	1.0	10.7	0.3	1.3	14.7±0.6	330	18.2	10
6	06C001	1.0	1.4	1.0	1.0	11.7	0.3	1.3	15.7±0.6	370	18.2	9
7	07C001	1.0	1.4	1.0	1.0	11.7	0.3	1.3	15.7±0.6	385	18.2	9
8	08C001	1.0	1.4	1.0	1.0	12.7	0.3	1.4	16.9±0.6	435	18.2	9
9	09C001	1.0	1.4	1.0	1.0	13.7	0.3	1.4	17.9±0.6	475	18.2	8
10	10C001	1.0	1.4	1.0	1.0	15.0	0.3	1.5	19.4±0.6	520	18.2	8
12	12C001	1.0	1.4	1.0	1.0	15.5	0.3	1.5	19.9±0.6	565	18.2	7
14	14C001	1.0	1.4	1.0	1.0	16.4	0.3	1.5	20.8±0.6	620	18.2	7
16	16C001	1.0	1.4	1.0	1.0	17.3	0.3	1.5	21.7±0.6	680	18.2	7
19	19C001	1.0	1.4	1.0	1.0	18.3	0.3	1.6	22.9±0.6	755	18.2	6
20	20C001	1.0	1.4	1.0	1.0	18.9	0.3	1.6	23.5±0.6	800	18.2	6
23	23C001	1.0	1.4	1.0	1.0	20.3	0.3	1.7	25.1±1.0	895	18.2	6
24	24C001	1.0	1.4	1.0	1.0	21.6	0.3	1.7	26.4±1.1	940	18.2	6
27	27C001	1.0	1.4	1.0	1.0	22.1	0.3	1.7	26.9±1.1	1005	18.2	6
30	30C001	1.0	1.4	1.0	1.0	23.0	0.3	1.8	28.0±1.1	1095	18.2	5
33	33C001	1.0	1.4	1.0	1.0	23.9	0.3	1.8	28.9±1.2	1170	18.2	5
37	37C001	1.0	1.4	1.0	1.0	24.9	0.3	1.9	30.1±1.2	1270	18.2	5
44	44C001	1.0	1.4	1.0	1.2	28.5	0.3	2.0	33.9±1.4	1525	18.2	5
5	05C015	1.5	1.7	1.0	1.0	11.5	0.3	1.3	15.5±0.6	380	12.2	13
6	06C015	1.5	1.7	1.0	1.0	12.6	0.3	1.4	16.8±0.6	435	12.2	12
7	07C015	1.5	1.7	1.0	1.0	12.6	0.3	1.4	16.8±0.6	450	12.2	12
8	08C015	1.5	1.7	1.0	1.0	13.7	0.3	1.4	17.9±0.6	505	12.2	11
9	09C015	1.5	1.7	1.0	1.0	14.8	0.3	1.4	19.0±0.6	555	12.2	11
10	10C015	1.5	1.7	1.0	1.0	16.2	0.3	1.5	20.6±0.6	605	12.2	10
12	12C015	1.5	1.7	1.0	1.0	16.8	0.3	1.5	21.2±0.6	665	12.2	10
14	14C015	1.5	1.7	1.0	1.0	17.7	0.3	1.6	22.3±0.6	745	12.2	9
16	16C015	1.5	1.7	1.0	1.0	18.7	0.3	1.6	23.3±0.6	820	12.2	9
19	19C015	1.5	1.7	1.0	1.0	19.8	0.3	1.6	24.4±0.6	900	12.2	8
20	20C015	1.5	1.7	1.0	1.0	20.4	0.3	1.7	25.2±1.0	975	12.2	8
23	23C015	1.5	1.7	1.0	1.0	22.0	0.3	1.7	26.8±1.1	1080	12.2	8
24	24C015	1.5	1.7	1.0	1.0	23.4	0.3	1.8	28.4±1.1	1140	12.2	7
27	27C015	1.5	1.7	1.0	1.0	24.0	0.3	1.8	29.0±1.2	1225	12.2	7
30	30C015	1.5	1.7	1.0	1.0	24.9	0.3	1.9	30.1±1.2	1335	12.2	7
33	33C015	1.5	1.7	1.0	1.0	25.9	0.3	1.9	31.1±1.2	1435	12.2	7
37	37C015	1.5	1.7	1.0	1.2	27.3	0.3	1.9	32.5±1.3	1565	12.2	6
44	44C015	1.5	1.7	1.0	1.2	30.9	0.4	2.1	36.9±1.5	1945	12.2	6

High Voltage Flame Retardant Cable

High Voltage Flame & Fire Resistant Cable

Low Voltage Flame Retardant Cable

Low Voltage Flame & Fire Resistant Cable

Technical information

Example) 0.6/1kV SFOU 5C x1.5mm² Part No. QESD05C015

Q NEK606	E SFOU	S Fire resistant (SR)	D 0.6/1kV	05C No. of cores	015 Size (mm ²)
--------------------	------------------	---------------------------------	---------------------	----------------------------	---------------------------------------

0.6/1kV Armored Flame retardant, Halogen free Cable (Code 0.6/1kV RFOU [P101])
0.6/1kV Armored Flame & Fire Resistant, Halogen free Cable (Code 0.6/1kV SFOU [P125])

No. of core	Part no.	Conductor		Thickness of insulation	Thickness of inner covering	Nominal dia. over inner covering	Dia. of metal wire for braid	Thickness of outer sheath	Nominal overall dia.	Cable weight approx	Conductor resistance (20 °C)	Current rating at 45 °C
		Nominal sectional area	Max. overall dia.									
EA	QETD/QESD	mm ²	mm	mm	mm	mm	mm	mm	mm	kg/km	Ω /km	Amp.
5	05C025	2.5	2.2	1.0	1.0	12.6	0.3	1.4	16.8±0.6	460	7.56	17
6	06C025	2.5	2.2	1.0	1.0	13.8	0.3	1.4	18.0±0.6	525	7.56	16
7	07C025	2.5	2.2	1.0	1.0	13.8	0.3	1.4	18.0±0.6	550	7.56	15
8	08C025	2.5	2.2	1.0	1.0	15.0	0.3	1.5	19.4±0.6	625	7.56	15
9	09C025	2.5	2.2	1.0	1.0	16.3	0.3	1.5	20.7±0.6	695	7.56	14
10	10C025	2.5	2.2	1.0	1.0	17.8	0.3	1.6	22.4±0.6	755	7.56	13
12	12C025	2.5	2.2	1.0	1.0	18.4	0.3	1.6	23.0±0.6	835	7.56	13
14	14C025	2.5	2.2	1.0	1.0	19.5	0.3	1.6	24.1±0.6	930	7.56	12
16	16C025	2.5	2.2	1.0	1.0	20.6	0.3	1.7	25.4±1.7	1040	7.56	11
19	19C025	2.5	2.2	1.0	1.0	21.8	0.3	1.7	26.6±1.1	1150	7.56	11
20	20C025	2.5	2.2	1.0	1.0	22.5	0.3	1.8	27.5±1.1	1240	7.56	11
23	23C025	2.5	2.2	1.0	1.0	24.3	0.3	1.8	29.3±1.2	1380	7.56	10
24	24C025	2.5	2.2	1.0	1.0	25.8	0.3	1.9	31.0±1.2	1455	7.56	10
27	27C025	2.5	2.2	1.0	1.0	26.4	0.3	1.9	31.6±1.3	1570	7.56	10
30	30C025	2.5	2.2	1.0	1.2	27.8	0.3	2.0	33.2±1.3	1740	7.56	9
33	33C025	2.5	2.2	1.0	1.2	28.9	0.3	2.0	34.3±1.4	1875	7.56	9
37	37C025	2.5	2.2	1.0	1.2	30.1	0.4	2.1	36.1±1.4	2115	7.56	9
44	44C025	2.5	2.2	1.0	1.2	24.1	0.4	2.1	40.3±1.6	2500	7.56	8

Example) 0.6/1kV RFOU 5C x2.5mm² Part No. QETD05C025

Q NEK606	E RFOU	T Flame retardant	D 0.6/1kV	05C No. of cores	025 Size (mm ²)
--------------------	------------------	-----------------------------	---------------------	----------------------------	---------------------------------------

LV Instrument cable

Armored Flame Retardant, Halogen free collective screened Instrument Cables (250V RFOU(C))
 Armored Flame & Fire resistant, Halogen free collective screened Instrument Cables (250V SFOU(C))

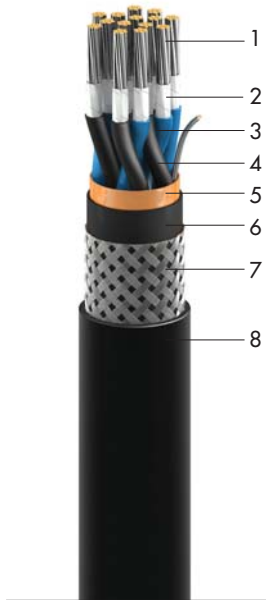

Application

- Instrument circuit up to 250V, instrument safe systems.
- Fixed installation for instrument, communication, control and alarm systems in both explosion risk and safe areas, general purposes.
- Maximum operating conductor temperature 90°C

Construction Details

- 1 Conductor** : Circular tinned stranded copper wires as per IEC 60228 Class 2 or Class 5 & IEC 60092-376
- 2 Insulation** : Halogen-free Ethylene propylene rubber (EPR-RFOU) or Silicone rubber (S95-SFOU) as per IEC 60092-360
- 3 Pair/triple twisting** : Two/three insulated cores twisted together with suitable lay length
- 4 Core assembly** : Pairs/triples are laid up with non-hygroscopic fillers and the binder tape may be applicable
- 5 Collective screening** : Wrapped by copper or aluminium backed polyester tape with tinned copper drain wire
- 6 Bedding** : Halogen-free compound (Inner covering)
- 7 Armor** : Copper wires braid (screen) as per IEC 60092-376
 — RFCU(option) : Galvanized steel wire braid as per IEC 60092-376
- 8 Outer Sheath**
 Halogen-free thermosetting compound as per IEC 60092-360, SHF2 or SHF2 Oil & Mud

Standards Applied

- **Design guideline** : IEC 60092-376, NEK606
- **Material properties** : IEC 60092-360, Insulation (EPR, S95)
 IEC 60092-360, Sheath (SHF2)
- **Flame retardant** : IEC 60332-3, Cat. 'A'
- **Fire resistant(SFOU)** : IEC 60331-1/2 at 830°C for 120min.
 (option) waterspray for 15min
- **Assessment of halogen** : IEC 60754-1/2 & 60684-2
- **Low smoke properties** : IEC 61034-1/2
- **Sunlight resistance** : UL 1581
- **Cold properties(option)** : CSA C22.2 No. 03. Cold bending(-50°C), Cold impact(-50°C)
- **Oil/Mud resistance(option)** : NEK TS 606 5th ed (Category a, b, c, d)

Identification of color

- **Insulation** : -1 Pair : Black, Light Blue
 -2 Pair and above : Numbering on Black & Light Blue insulation core
 -1 Triple : Black, Light Blue, Brown
 -2 Triple and above : Numbering on Black, Light Blue & Brown insulation core
- **Outer sheath** : -Non I.S : Grey
 -I.S : Light Blue

Note) The any other identification of color may be applicable when purchaser required



-35 to 90°C



Flame & Fire resistant
 IEC 60332-3 A
 & IEC 60331(SFOU)



Cold impact
 CSA C22.2 No.38, -65°C
 Special requirement



Halogen free



Weather
 Resistance to severe
 weather conditions



Chemical attacks
 Resistance to
 chemicals



Smoke-Corrosivity-Toxicity
 Smoke density, gases corrosivity and toxicity



Resistance to Mud
 NEK TS 606



Resistance to
 Enhanced oil &
 Hydraulic/gear oil

Approvals

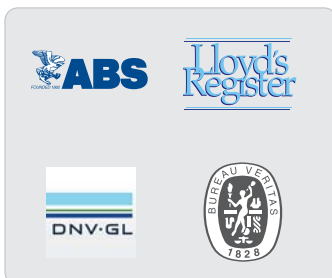

High Voltage Flame
 Retardant Cable

High Voltage Flame
 & Fire Resistant Cable

Low Voltage Flame
 Retardant Cable

Low Voltage Flame
 & Fire Resistant Cable

Technical information

250V Armored Flame retardant, Halogen free collective screened Instrument Cable (Code : 250V RFOU(C) [S102])

250V Armored Flame & Fire resistant, Halogen free collective screened Instrument Cable (Code : 250V SFOU(C) [S113])

No. of pair	No. of core	Part no.	Conductor		Thickness of insulation	Thickness of inner covering	Nominal dia. over inner covering	Dia. of metal wire for braid	Thickness of outer sheath	Nominal overall dia.	Cable weight approx	Conductor resistance (20°C)
			Nominal sectional area	Max. overall dia.								
Pr	EA	QVTA/QVSA	mm ²	mm	mm	mm	mm	mm	mm	mm	kg/km	Ω /km
1	2	01P075	0.75	1.2	0.6	1.0	6.8	0.2	1.1	9.9±0.6	150	26.3
2	4	02P075	0.75	1.2	0.6	1.0	10.2	0.3	1.3	14.2±0.6	255	26.3
3	6	03P075	0.75	1.2	0.6	1.0	10.7	0.3	1.3	14.7±0.6	335	26.3
4	8	04P075	0.75	1.2	0.6	1.0	11.6	0.3	1.3	15.6±0.6	380	26.3
5	10	05P075	0.75	1.2	0.6	1.0	12.7	0.3	1.4	16.9±0.6	435	26.3
6	12	06P075	0.75	1.2	0.6	1.0	13.9	0.3	1.4	18.1±0.6	505	26.3
7	14	07P075	0.75	1.2	0.6	1.0	13.9	0.3	1.4	18.1±0.6	525	26.3
8	16	08P075	0.75	1.2	0.6	1.0	15.3	0.3	1.5	19.7±0.6	585	26.3
9	18	09P075	0.75	1.2	0.6	1.0	16.4	0.3	1.5	20.8±0.6	655	26.3
10	20	10P075	0.75	1.2	0.6	1.0	17.2	0.3	1.5	21.6±0.6	690	26.3
12	24	12P075	0.75	1.2	0.6	1.0	17.7	0.3	1.6	22.3±0.6	760	26.3
14	28	14P075	0.75	1.2	0.6	1.0	18.7	0.3	1.6	23.3±0.6	850	26.3
15	30	15P075	0.75	1.2	0.6	1.0	20.1	0.3	1.7	24.9±0.6	920	26.3
16	32	16P075	0.75	1.2	0.6	1.0	20.5	0.3	1.7	25.3±1.0	955	26.3
18	36	18P075	0.75	1.2	0.6	1.0	21.7	0.3	1.7	26.5±1.1	1,055	26.3
19	38	19P075	0.75	1.2	0.6	1.0	21.9	0.3	1.7	26.7±1.1	1,070	26.3
20	40	20P075	0.75	1.2	0.6	1.0	22.9	0.3	1.8	27.9±1.1	1,140	26.3
21	42	21P075	0.75	1.2	0.6	1.0	23.6	0.3	1.8	28.6±1.1	1,210	26.3
23	46	23P075	0.75	1.2	0.6	1.0	24.0	0.3	1.8	29.0±1.2	1,265	26.3
24	48	24P075	0.75	1.2	0.6	1.0	25.3	0.3	1.9	30.5±1.2	1,320	26.3
27	54	27P075	0.75	1.2	0.6	1.2	25.9	0.3	1.9	31.1±1.2	1,435	26.3
30	60	30P075	0.75	1.2	0.6	1.2	27.2	0.3	1.9	32.4±1.3	1,550	26.3
32	64	32P075	0.75	1.2	0.6	1.2	28.0	0.3	2.0	33.4±1.3	1,635	26.3
37	74	37P075	0.75	1.2	0.6	1.2	29.3	0.3	2.0	34.7±1.4	1,835	26.3

Example) 250V RFOU(C)1Pr x 0.75mm² Part No. QVTA01P075

Q NEK606	V RFOU(C)	T Flame retardant	A 150/250V	01P No. of Pair	075 Size (mm ²)
--------------------	---------------------	-----------------------------	----------------------	---------------------------	---------------------------------------

250V Armored Flame retardant, Halogen free collective screened Instrument Cable (Code : 250V RFOU(C) [S102])

250V Armored Flame & Fire resistant, Halogen free collective screened Instrument Cable (Code : 250V SFOU(C) [S113])

No. of pair	No. of core	Part no.	Conductor		Thickness of insulation	Thickness of inner covering	Nominal dia. over inner covering	Dia. of metal wire for braid	Thickness of outer sheath	Nominal overall dia.	Cable weight approx	Conductor resistance (20°C)
			Nominal sectional area	Max. overall dia.								
Pr	EA	QVTA/QVSA	mm ²	mm	mm	mm	mm	mm	mm	mm	kg/km	Ω /km
1	2	01P001	1.0	1.4	0.6	1.0	7.0	0.2	1.1	10.1±0.6	160	19.3
2	4	02P001	1.0	1.4	0.6	1.0	10.5	0.3	1.3	14.5±0.6	315	19.3
3	6	03P001	1.0	1.4	0.6	1.0	11.1	0.3	1.3	15.1±0.6	360	19.3
4	8	04P001	1.0	1.4	0.6	1.0	11.9	0.3	1.3	15.9±0.6	410	19.3
5	10	05P001	1.0	1.4	0.6	1.0	13.1	0.3	1.4	17.3±0.6	480	19.3
6	12	06P001	1.0	1.4	0.6	1.0	14.4	0.3	1.4	18.6±0.6	545	19.3
7	14	07P001	1.0	1.4	0.6	1.0	14.4	0.3	1.4	18.6±0.6	570	19.3
8	16	08P001	1.0	1.4	0.6	1.0	15.8	0.3	1.5	20.2±0.6	650	19.3
9	18	09P001	1.0	1.4	0.6	1.0	16.9	0.3	1.5	21.3±0.6	715	19.3
10	20	10P001	1.0	1.4	0.6	1.0	17.8	0.3	1.6	22.4±0.6	750	19.3
12	24	12P001	1.0	1.4	0.6	1.0	18.3	0.3	1.6	22.9±0.6	840	19.3
14	28	14P001	1.0	1.4	0.6	1.0	19.4	0.3	1.6	24.0±0.6	935	19.3
15	30	15P001	1.0	1.4	0.6	1.0	20.8	0.3	1.7	25.6±1.0	1,020	19.3
16	32	16P001	1.0	1.4	0.6	1.0	21.2	0.3	1.7	26.0±1.0	1,060	19.3
18	36	18P001	1.0	1.4	0.6	1.0	22.4	0.3	1.8	27.4±1.1	1,160	19.3
19	38	19P001	1.0	1.4	0.6	1.0	22.7	0.3	1.8	27.7±1.1	1,175	19.3
20	40	20P001	1.0	1.4	0.6	1.0	23.7	0.3	1.8	28.7±1.1	1,270	19.3
21	42	21P001	1.0	1.4	0.6	1.0	24.5	0.3	1.8	29.5±1.2	1,330	19.3
23	46	23P001	1.0	1.4	0.6	1.0	24.9	0.3	1.9	30.1±1.2	1,395	19.3
24	48	24P001	1.0	1.4	0.6	1.0	26.2	0.3	1.9	31.4±1.3	1,465	19.3
27	54	27P001	1.0	1.4	0.6	1.2	27.2	0.3	1.9	32.4±1.3	1,585	19.3
30	60	30P001	1.0	1.4	0.6	1.2	28.2	0.3	2.0	33.6±1.3	1,735	19.3
32	64	32P001	1.0	1.4	0.6	1.2	29.0	0.3	2.0	34.4±1.4	1,850	19.3
37	74	37P001	1.0	1.4	0.6	1.2	30.4	0.4	2.1	36.4±1.5	2,030	19.3
1	2	01P015	1.5	1.7	0.7	1.0	8.0	0.2	1.2	11.3±0.6	190	12.9
2	4	02P015	1.5	1.7	0.7	1.0	12.2	0.3	1.3	16.2±0.6	390	12.9
3	6	03P015	1.5	1.7	0.7	1.0	12.8	0.3	1.4	17.0±0.6	455	12.9
4	8	04P015	1.5	1.7	0.7	1.0	13.9	0.3	1.4	18.1±0.6	530	12.9
5	10	05P015	1.5	1.7	0.7	1.0	15.3	0.3	1.5	19.7±0.6	625	12.9
6	12	06P015	1.5	1.7	0.7	1.0	16.8	0.3	1.5	21.2±0.6	715	12.9
7	14	07P015	1.5	1.7	0.7	1.0	16.8	0.3	1.5	21.2±0.6	750	12.9
8	16	08P015	1.5	1.7	0.7	1.0	18.5	0.3	1.6	23.1±0.6	855	12.9
9	18	09P015	1.5	1.7	0.7	1.0	19.8	0.3	1.6	24.4±0.6	950	12.9
10	20	10P015	1.5	1.7	0.7	1.0	20.9	0.3	1.7	25.7±1.0	1,020	12.9
12	24	12P015	1.5	1.7	0.7	1.0	21.5	0.3	1.7	26.3±1.1	1,130	12.9
14	28	14P015	1.5	1.7	0.7	1.0	22.7	0.3	1.8	27.7±1.1	1,260	12.9
15	30	15P015	1.5	1.7	0.7	1.0	24.5	0.3	1.8	29.5±1.2	1,375	12.9
16	32	16P015	1.5	1.7	0.7	1.0	24.9	0.3	1.9	30.1±1.2	1,430	12.9
18	36	18P015	1.5	1.7	0.7	1.0	26.4	0.3	1.9	31.6±1.3	1,585	12.9
19	38	19P015	1.5	1.7	0.7	1.2	27.0	0.3	1.9	32.2±1.3	1,610	12.9
20	40	20P015	1.5	1.7	0.7	1.2	28.2	0.3	2.0	33.6±1.3	1,765	12.9
21	42	21P015	1.5	1.7	0.7	1.2	29.1	0.3	2.0	34.5±1.4	1,850	12.9
23	46	23P015	1.5	1.7	0.7	1.2	29.6	0.3	2.0	35.0±1.4	1,945	12.9
24	48	24P015	1.5	1.7	0.7	1.2	31.2	0.4	2.1	37.2±1.5	2,120	12.9
27	54	27P015	1.5	1.7	0.7	1.2	32.0	0.4	2.2	38.2±1.5	2,290	12.9
30	60	30P015	1.5	1.7	0.7	1.2	33.2	0.4	2.2	39.4±1.6	2,495	12.9
32	64	32P015	1.5	1.7	0.7	1.2	34.1	0.4	2.2	40.3±1.6	2,635	12.9
37	74	37P015	1.5	1.7	0.7	1.2	35.8	0.4	2.3	42.2±1.7	2,930	12.9

Example) 250V SFOU(C)1Pr x 1.5mm² Part No. QVSA01P015

Q NEK606	V SFOU(C)	S Fire resistant (SR)	A 150/250V	01P No. of Pair	015 Size (mm ²)
--------------------	---------------------	---------------------------------	----------------------	---------------------------	---------------------------------------

High Voltage Flame Retardant Cable

High Voltage Flame & Fire Resistant Cable

Low Voltage Flame Retardant Cable

Low Voltage Flame & Fire Resistant Cable

Technical information

250V Armored Flame retardant, Halogen free collective screened Instrument Cable (Code : 250V RFOU(C) [S102])

250V Armored Flame & Fire resistant, Halogen free collective screened Instrument Cable (Code : 250V SFOU(C) [S113])

No. of pair	No. of core	Part no.	Conductor		Thickness of insulation	Thickness of inner covering	Nominal dia. over inner covering	Dia. of metal wire for braid	Thickness of outer sheath	Nominal overall dia.	Cable weight approx	Conductor resistance (20°C)
			Nominal sectional area	Max. overall dia.								
Pr	EA	QVTA/QVSA	mm ²	mm	mm	mm	mm	mm	mm	mm	kg/km	Ω /km
1	2	01P025	2.5	2.2	0.7	1.0	8.8	0.2	1.2	12.1±0.6	235	8.02
2	4	02P025	2.5	2.2	0.7	1.0	13.5	0.3	1.4	17.7±0.6	475	8.02
3	6	03P025	2.5	2.2	0.7	1.0	14.3	0.3	1.4	18.5±0.6	560	8.02
4	8	04P025	2.5	2.2	0.7	1.0	15.4	0.3	1.5	19.8±0.6	670	8.02
5	10	05P025	2.5	2.2	0.7	1.0	17.0	0.3	1.5	21.4±0.6	780	8.02
6	12	06P025	2.5	2.2	0.7	1.0	18.7	0.3	1.6	23.3±0.6	910	8.02
7	14	07P025	2.5	2.2	0.7	1.0	18.7	0.3	1.6	23.3±0.6	970	8.02
8	16	08P025	2.5	2.2	0.7	1.0	20.6	0.3	1.7	25.4±1.0	1,110	8.02
9	18	09P025	2.5	2.2	0.7	1.0	22.1	0.3	1.7	26.9±1.1	1,230	8.02
10	20	10P025	2.5	2.2	0.7	1.0	23.3	0.3	1.8	28.3±1.1	1,315	8.02
12	24	12P025	2.5	2.2	0.7	1.0	24.0	0.3	1.8	29.0±1.2	1,475	8.02
14	28	14P025	2.5	2.2	0.7	1.0	25.4	0.3	1.9	30.6±1.2	1,655	8.02
15	30	15P025	2.5	2.2	0.7	1.2	27.7	0.3	2.0	33.1±1.3	1,830	8.02
16	32	16P025	2.5	2.2	0.7	1.2	28.2	0.3	2.0	33.6±1.3	1,920	8.02
18	36	18P025	2.5	2.2	0.7	1.2	29.9	0.3	2.1	35.5±1.4	2,115	8.02
19	38	19P025	2.5	2.2	0.7	1.2	30.2	0.4	2.1	36.2±1.4	2,155	8.02
20	40	20P025	2.5	2.2	0.7	1.2	31.6	0.4	2.1	37.6±1.5	2,395	8.02
21	42	21P025	2.5	2.2	0.7	1.2	32.6	0.4	2.2	38.8±1.6	2,515	8.02
23	46	23P025	2.5	2.2	0.7	1.2	33.1	0.4	2.2	39.3±1.6	2,675	8.02
24	48	24P025	2.5	2.2	0.7	1.2	35.0	0.4	2.3	41.4±1.7	2,785	8.02
27	54	27P025	2.5	2.2	0.7	1.2	35.8	0.4	2.3	42.2±1.7	3,045	8.02
30	60	30P025	2.5	2.2	0.7	1.4	37.5	0.4	2.4	44.1±1.8	3,310	8.02
32	64	32P025	2.5	2.2	0.7	1.4	38.6	0.4	2.4	45.2±1.8	3,555	8.02
37	74	37P025	2.5	2.2	0.7	1.4	40.5	0.4	2.5	47.3±1.9	3,935	8.02

Example) 250V RFOU(C)1Pr x 2.5mm² Part No. QVTA01P025

Q NEK606	V RFOU(C)	T Flame retardant	A 150/250V	01P No. of Pair	025 Size (mm ²)
--------------------	---------------------	-----------------------------	----------------------	---------------------------	---------------------------------------

250V Armored Flame retardant, Halogen free collective screened Instrument Cable (Code : 250V RFOU(C) [S102])

250V Armored Flame & Fire resistant, Halogen free collective screened Instrument Cable (Code : 250V SFOU(C) [S113])

No. of Triad	No. of core	Part no.	Conductor		Thickness of insulation	Thickness of inner covering	Nominal dia. over inner covering	Dia. of metal wire for braid	Thickness of outer sheath	Nominal overall dia.	Cable weight approx	Conductor resistance (20°C)
			Nominal sectional area	Max. overall dia.								
Tr	EA	QVTA/QVSA	mm ²	mm	mm	mm	mm	mm	mm	mm	kg/km	Ω /km
1	3	01T075	0.75	1.2	0.6	1.0	7.2	0.2	1.1	10.3±0.6	165	26.3
2	6	02T075	0.75	1.2	0.6	1.0	11.2	0.3	1.3	15.2±0.6	340	26.3
3	9	03T075	0.75	1.2	0.6	1.0	11.7	0.3	1.3	15.7±0.6	390	26.3
4	12	04T075	0.75	1.2	0.6	1.0	12.7	0.3	1.4	16.9±0.6	450	26.3
5	15	05T075	0.75	1.2	0.6	1.0	13.9	0.3	1.4	18.1±0.6	525	26.3
6	18	06T075	0.75	1.2	0.6	1.0	15.7	0.3	1.5	20.1±0.6	615	26.3
7	21	07T075	0.75	1.2	0.6	1.0	15.7	0.3	1.5	20.1±0.6	645	26.3
8	24	08T075	0.75	1.2	0.6	1.0	16.9	0.3	1.5	21.3±0.6	720	26.3
9	27	09T075	0.75	1.2	0.6	1.0	18.2	0.3	1.6	22.8±0.6	805	26.3
10	30	10T075	0.75	1.2	0.6	1.0	19.7	0.3	1.6	24.3±0.6	865	26.3
12	36	12T075	0.75	1.2	0.6	1.0	20.4	0.3	1.7	25.2±1.0	965	26.3
14	42	14T075	0.75	1.2	0.6	1.0	21.4	0.3	1.7	26.2±1.0	1,080	26.3
15	45	15T075	0.75	1.2	0.6	1.0	22.2	0.3	1.7	27.0±1.1	1,145	26.3
16	48	16T075	0.75	1.2	0.6	1.0	22.9	0.3	1.8	27.9±1.1	1,200	26.3
18	54	18T075	0.75	1.2	0.6	1.0	24.2	0.3	1.8	29.2±1.2	1,325	26.3
19	57	19T075	0.75	1.2	0.6	1.0	24.4	0.3	1.8	29.4±1.2	1,345	26.3
20	60	20T075	0.75	1.2	0.6	1.0	25.2	0.3	1.9	30.4±1.2	1,430	26.3
21	63	21T075	0.75	1.2	0.6	1.0	25.7	0.3	1.9	30.9±1.2	1,495	26.3
23	69	23T075	0.75	1.2	0.6	1.2	27.2	0.3	1.9	32.4±1.3	1,605	26.3
24	72	24T075	0.75	1.2	0.6	1.2	27.7	0.3	2.0	33.1±1.3	1,650	26.3
27	81	27T075	0.75	1.2	0.6	1.2	29.2	0.3	2.0	34.6±1.4	1,845	26.3
30	90	30T075	0.75	1.2	0.6	1.2	30.7	0.4	2.1	36.7±1.5	2,005	26.3
32	96	32T075	0.75	1.2	0.6	1.2	31.6	0.4	2.1	37.6±1.5	2,215	26.3
1	3	01T001	1.0	1.4	0.6	1.0	7.4	0.2	1.1	10.5±0.6	180	19.3
2	6	02T001	1.0	1.4	0.6	1.0	11.5	0.3	1.3	15.5±0.6	365	19.3
3	9	03T001	1.0	1.4	0.6	1.0	12.0	0.3	1.3	16.0±0.6	420	19.3
4	12	04T001	1.0	1.4	0.6	1.0	13.1	0.3	1.4	17.3±0.6	495	19.3
5	15	05T001	1.0	1.4	0.6	1.0	14.4	0.3	1.4	18.6±0.6	570	19.3
6	18	06T001	1.0	1.4	0.6	1.0	16.2	0.3	1.5	20.6±0.6	670	19.3
7	21	07T001	1.0	1.4	0.6	1.0	16.2	0.3	1.5	20.6±0.6	710	19.3
8	24	08T001	1.0	1.4	0.6	1.0	17.5	0.3	1.6	22.1±0.6	790	19.3
9	27	09T001	1.0	1.4	0.6	1.0	18.8	0.3	1.6	23.4±0.6	885	19.3
10	30	10T001	1.0	1.4	0.6	1.0	20.4	0.3	1.7	25.2±1.0	955	19.3
12	36	12T001	1.0	1.4	0.6	1.0	21.1	0.3	1.7	25.9±1.0	1,070	19.3
14	42	14T001	1.0	1.4	0.6	1.0	22.2	0.3	1.7	27.0±1.1	1,190	19.3
15	45	15T001	1.0	1.4	0.6	1.0	23.0	0.3	1.8	28.0±1.1	1,270	19.3
16	48	16T001	1.0	1.4	0.6	1.0	23.7	0.3	1.8	28.7±1.1	1,340	19.3
18	54	18T001	1.0	1.4	0.6	1.0	25.0	0.3	1.9	30.2±1.2	1,470	19.3
19	57	19T001	1.0	1.4	0.6	1.0	25.3	0.3	1.9	30.5±1.2	1,495	19.3
20	60	20T001	1.0	1.4	0.6	1.0	26.1	0.3	1.9	31.3±1.3	1,600	19.3
21	63	21T001	1.0	1.4	0.6	1.2	27.0	0.3	1.9	32.2±1.3	1,675	19.3
23	69	23T001	1.0	1.4	0.6	1.2	28.2	0.3	2.0	33.6±1.3	1,805	19.3
24	72	24T001	1.0	1.4	0.6	1.2	28.7	0.3	2.0	34.1±1.4	1,875	19.3
27	81	27T001	1.0	1.4	0.6	1.2	30.3	0.4	2.1	36.3±1.5	2,050	19.3
30	90	30T001	1.0	1.4	0.6	1.2	31.8	0.4	2.1	37.8±1.5	2,325	19.3
32	96	32T001	1.0	1.4	0.6	1.2	32.8	0.4	2.2	39.0±1.6	2,455	19.3

Example)

250V RFOU(C)1Tr x 0.75mm² Part No. QVTA01T075

Q NEK606	V RFOU(C)	T Flame retardant	A 150/250V	01T No. of Triad	075 Size (mm ²)
--------------------	---------------------	-----------------------------	----------------------	----------------------------	---------------------------------------

High Voltage Flame Retardant Cable

High Voltage Flame & Fire Resistant Cable

Low Voltage Flame Retardant Cable

Low Voltage Flame & Fire Resistant Cable

Technical information

250V Armored Flame Retardant, Halogen free collective screened Instrument Cable (Code : 250V RFOU(C) [S102])

250V Armored Flame & Fire resistant, Halogen free collective screened Instrument Cable (Code : 250V SFOU(C) [S113])

No. of Triad	No. of core	Part no.	Conductor		Thickness of insulation	Thickness of inner covering	Nominal dia. over inner covering	Dia. of metal wire for braid	Thickness of outer sheath	Nominal overall dia.	Cable weight approx	Conductor resistance (20°C)
			Nominal sectional area	Max. overall dia.								
Tr	EA	QVTA/QVSA	mm ²	mm	mm	mm	mm	mm	mm	mm	kg/km	Ω/km
1	3	01T015	1.5	1.7	0.7	1.0	8.5	0.2	1.2	11.8±0.6	225	12.9
2	6	02T015	1.5	1.7	0.7	1.0	13.4	0.3	1.4	17.6±0.6	460	12.9
3	9	03T015	1.5	1.7	0.7	1.0	14.0	0.3	1.4	18.2±0.6	540	12.9
4	12	04T015	1.5	1.7	0.7	1.0	15.2	0.3	1.5	19.6±0.6	640	12.9
5	15	05T015	1.5	1.7	0.7	1.0	16.8	0.3	1.5	21.2±0.6	755	12.9
6	18	06T015	1.5	1.7	0.7	1.0	19.0	0.3	1.6	23.6±0.6	890	12.9
7	21	07T015	1.5	1.7	0.7	1.0	19.0	0.3	1.6	23.6±0.6	950	12.9
8	24	08T015	1.5	1.7	0.7	1.0	20.5	0.3	1.7	25.3±1.0	1,075	12.9
9	27	09T015	1.5	1.7	0.7	1.0	22.1	0.3	1.7	26.9±1.1	1,195	12.9
10	30	10T015	1.5	1.7	0.7	1.0	23.9	0.3	1.8	28.9±1.2	1,295	12.9
12	36	12T015	1.5	1.7	0.7	1.0	24.8	0.3	1.8	29.8±1.2	1,450	12.9
14	42	14T015	1.5	1.7	0.7	1.0	26.1	0.3	1.9	31.3±1.3	1,640	12.9
15	45	15T015	1.5	1.7	0.7	1.2	27.3	0.3	1.9	32.5±1.3	1,750	12.9
16	48	16T015	1.5	1.7	0.7	1.2	28.2	0.3	2.0	33.6±1.3	1,870	12.9
18	54	18T015	1.5	1.7	0.7	1.2	29.8	0.4	2.0	35.2±1.4	2,055	12.9
19	57	19T015	1.5	1.7	0.7	1.2	30.1	0.4	2.1	36.1±1.4	2,095	12.9
20	60	20T015	1.5	1.7	0.7	1.2	31.0	0.4	2.1	37.0±1.5	2,320	12.9
21	63	21T015	1.5	1.7	0.7	1.2	31.7	0.4	2.1	37.7±1.5	2,425	12.9
23	69	23T015	1.5	1.7	0.7	1.2	33.1	0.4	2.2	39.3±1.6	2,600	12.9
24	72	24T015	1.5	1.7	0.7	1.2	33.8	0.4	2.2	40.0±1.6	2,680	12.9
27	81	27T015	1.5	1.7	0.7	1.2	35.7	0.4	2.3	42.1±1.7	2,960	12.9
30	90	30T015	1.5	1.7	0.7	1.4	37.8	0.4	2.4	44.4±1.8	3,225	12.9
32	96	32T015	1.5	1.7	0.7	1.4	39.0	0.4	2.4	45.6±1.8	3,465	12.9
1	3	01T025	2.5	2.2	0.7	1.0	9.3	0.3	1.2	12.6±0.6	270	8.02
2	6	02T025	2.5	2.2	0.7	1.0	14.9	0.3	1.5	19.3±0.6	565	8.02
3	9	03T025	2.5	2.2	0.7	1.0	15.6	0.3	1.5	20.0±0.6	685	8.02
4	12	04T025	2.5	2.2	0.7	1.0	17.0	0.3	1.5	21.4±0.6	820	8.02
5	15	05T025	2.5	2.2	0.7	1.0	18.7	0.3	1.6	23.3±0.6	980	8.02
6	18	06T025	2.5	2.2	0.7	1.0	21.2	0.3	1.7	26.0±1.0	1,160	8.02
7	21	07T025	2.5	2.2	0.7	1.0	21.2	0.3	1.7	26.0±1.0	1,240	8.02
8	24	08T025	2.5	2.2	0.7	1.0	22.9	0.3	1.8	27.9±1.1	1,395	8.02
9	27	09T025	2.5	2.2	0.7	1.0	24.7	0.3	1.8	29.7±1.2	1,570	8.02
10	30	10T025	2.5	2.2	0.7	1.2	27.1	0.3	1.9	32.3±1.3	1,700	8.02
12	36	12T025	2.5	2.2	0.7	1.2	28.1	0.3	2.0	33.5±1.3	1,965	8.02
14	42	14T025	2.5	2.2	0.7	1.2	29.5	0.3	2.0	34.9±1.4	2,205	8.02
15	45	15T025	2.5	2.2	0.7	1.2	30.6	0.4	2.1	36.6±1.5	2,355	8.02
16	48	16T025	2.5	2.2	0.7	1.2	31.6	0.4	2.1	37.6±1.5	2,565	8.02
18	54	18T015	2.5	2.2	0.7	1.2	33.4	0.4	2.2	39.6±1.6	2,845	8.02
19	57	19T025	2.5	2.2	0.7	1.2	33.7	0.4	2.2	39.9±1.6	2,905	8.02
20	60	20T025	2.5	2.2	0.7	1.2	34.8	0.4	2.3	41.2±1.6	3,090	8.02
21	63	21T025	2.5	2.2	0.7	1.2	35.6	0.4	2.3	42.0±1.7	3,255	8.02
23	69	23T025	2.5	2.2	0.7	1.4	37.4	0.4	2.4	44.0±1.8	3,475	8.02
24	72	24T025	2.5	2.2	0.7	1.4	38.2	0.4	2.4	44.8±1.8	3,590	8.02
27	81	27T025	2.5	2.2	0.7	1.4	40.3	0.4	2.5	47.1±1.9	4,005	8.02
30	90	30T025	2.5	2.2	0.7	1.4	42.4	0.4	2.6	49.4±2.0	4,400	8.02
32	96	32T025	2.5	2.2	0.7	1.4	43.7	0.4	2.6	50.7±2.0	4,685	8.02

Example) 250V SFOU(C)1Tr x 1.5mm² Part No. QVSA01T015

Q NEK606	V SFOU(C)	S Fire resistant (SR)	A 150/250V	01T No. of Triad	015 Size (mm ²)
--------------------	---------------------	---------------------------------	----------------------	----------------------------	---------------------------------------

LV Instrument cable

Armored Flame Retardant, Halogen free Individually screened Instrument Cables (250V RFOU(I), RFOU(I)/C)
 Armored Flame & Fire resistant, Halogen free Individually screened Instrument Cables (250V SFOU(I), SFOU(I)/C)



Application

- Instrument circuit up to 250V, instrument safe systems.
- Fixed installation for instrument, communication, control and alarm systems in both explosion risk and safe areas, general purposes.
- Maximum operating conductor temperature 90°C

Construction Details

- 1 Conductor** : Circular tinned stranded copper wires as per IEC 60228 Class 2 or Class 5 & IEC 60092-376
- 2 Insulation** : Halogen-free Ethylene propylene rubber(EPR-RFOU) or Silicon rubber (S95-SFOU) as per IEC 60092-360
- 3 Pair/triple twisting** : Two/three insulated cores twisted together with suitable lay length
- 4 Individual screening** : Wrapped by copper or aluminium backed polyester tape with tinned copper drain wire
- 5 Core assembly** : Screened pairs/triples are laid up with non-hygroscopic fillers and the binder tape may be applicable
- 6 Collective screening** (option) : Wrapped by copper or aluminium backed polyester tape with tinned copper drain wire
- 7 Bedding** : Halogen-free compound(Inner covering)
- 8 Armor** : Copper wires braid(screen) as per IEC 60092-376
 — RFCU(option) : Galvanized steel wire braid as per IEC 60092-376
- 9 Outer Sheath** : Halogen-free thermosetting compounding as per IEC 60092-360, SHF2 or SHF2 Oil & Mud

Standards Applied

- **Design guideline** : IEC 60092-376, NEK606
- **Material properties** : IEC 60092-360, Insulation (EPR, S95)
 IEC 60092-360, Sheath (SHF2)
- **Flame retardant** : IEC 60332-3, Cat. 'A'
- **Fire resistant(SFOU)**: IEC 60331-1&2 at 830°C for 120 min.
 (option) waterspray for 15min
- **Assessment of halogen** : IEC 60754-1/2 & 60684-2
- **Low smoke properties** : IEC 61034-1/2
- **Sunlight resistance** : UL 1581
- **Cold properties(option)** : CSA C22.2 No. 03. Cold bending(-50°C), Cold impact(-50°C)
- **Oil/Mud resistance(option)** : NEK TS 606 5th ed (Category a, b, c, d)

Approvals



-35 to 90°C



Flame & Fire resistant
 IEC 60332-3 A
 & IEC 60331



Cold impact
 CSA C22.2 No.38, -65°C
 Special requirement



Halogen free



Weather
 Resistance to severe
 weather conditions



Chemical attacks
 Resistance to
 chemicals



Smoke-Corrosivity-Toxicity
 Smoke density, gases corrosivity and toxicity



Resistance to Mud
 NEK TS 606



Resistance to
 Enhanced oil &
 Hydraulic/gear oil

High Voltage Flame
 Retardant Cable

High Voltage Flame
 & Fire Resistant Cable

Low Voltage Flame
 Retardant Cable

Low Voltage Flame
 & Fire Resistant Cable

Technical information

250V Armored Flame retardant, Halogen free Individually screened Instrument Cable (Code : 250V RFOU(I)[S101], RFOU(I/C))

250V Armored Flame & Fire resistant, Halogen free Individually screened Instrument Cable (Code : 250V SFOU(I)[S112], SFOU(I/C))

No. of pair	No. of core	Part no.	Conductor		Thickness of insulation	Thickness of inner covering	Nominal dia. over inner covering	Dia. of metal wire for braid	Thickness of outer sheath	Nominal overall dia.	Cable weight approx	Conductor resistance (20°C)
			Nominal sectional area	Max. overall dia.								
Pr	EA	QSTA/QSSA	mm ²	mm	mm	mm	mm	mm	mm	mm	kg/km	Ω /km
1	2	01P075	0.75	1.2	0.6	1.0	6.8	0.2	1.1	9.9±0.6	155	26.3
2	4	02P075	0.75	1.2	0.6	1.0	10.5	0.3	1.3	14.5±0.6	325	26.3
3	6	03P075	0.75	1.2	0.6	1.0	11.1	0.3	1.3	15.1±0.6	375	26.3
4	8	04P075	0.75	1.2	0.6	1.0	11.9	0.3	1.3	15.9±0.6	435	26.3
5	10	05P075	0.75	1.2	0.6	1.0	13.1	0.3	1.4	17.3±0.6	510	26.3
6	12	06P075	0.75	1.2	0.6	1.0	14.4	0.3	1.4	18.6±0.6	580	26.3
7	14	07P075	0.75	1.2	0.6	1.0	14.4	0.3	1.4	18.6±0.6	610	26.3
8	16	08P075	0.75	1.2	0.6	1.0	15.8	0.3	1.5	20.2±0.6	695	26.3
9	18	09P075	0.75	1.2	0.6	1.0	16.9	0.3	1.5	21.3±0.6	770	26.3
10	20	10P075	0.75	1.2	0.6	1.0	17.8	0.3	1.6	22.4±0.6	815	26.3
12	24	12P075	0.75	1.2	0.6	1.0	18.3	0.3	1.6	22.9±0.6	920	26.3
14	28	14P075	0.75	1.2	0.6	1.0	19.4	0.3	1.6	24.0±0.6	1,025	26.3
15	30	15P075	0.75	1.2	0.6	1.0	20.8	0.3	1.7	25.6±1.0	1,115	26.3
16	32	16P075	0.75	1.2	0.6	1.0	21.2	0.3	1.7	26.0±1.0	1,160	26.3
18	36	18P075	0.75	1.2	0.6	1.0	22.4	0.3	1.8	27.4±1.1	1,275	26.3
19	38	19P075	0.75	1.2	0.6	1.0	22.7	0.3	1.8	27.7±1.1	1,295	26.3
20	40	20P075	0.75	1.2	0.6	1.0	23.7	0.3	1.8	28.7±1.1	1,395	26.3
21	42	21P075	0.75	1.2	0.6	1.0	24.5	0.3	1.8	29.5±1.2	1,460	26.3
23	46	23P075	0.75	1.2	0.6	1.0	24.9	0.3	1.9	30.1±1.2	1,540	26.3
24	48	24P075	0.75	1.2	0.6	1.0	26.2	0.3	1.9	31.4±1.3	1,620	26.3
27	54	27P075	0.75	1.2	0.6	1.2	27.2	0.3	1.9	32.4±1.3	1,755	26.3
30	60	30P075	0.75	1.2	0.6	1.2	28.2	0.3	2.0	33.6±1.3	1,925	26.3
32	64	32P075	0.75	1.2	0.6	1.2	29.0	0.3	2.0	34.4±1.4	2,050	26.3
37	74	37P075	0.75	1.2	0.6	1.2	30.4	0.4	2.1	36.4±1.5	2,265	26.3

Example) 250V RFOU(I) 1Pr x 0.75mm² Part No. QSTA01P075

Q NEK606	S RFOU(I)	T Flame retardant	A 150/250V	01P No. of Pair	075 Size (mm ²)
--------------------	---------------------	-----------------------------	----------------------	---------------------------	---------------------------------------

250V Armored Flame retardant, Halogen free Individually screened Instrument Cable (Code : 250V RFOU(I)[S101], RFOU(I/C))
250V Armored Flame & Fire resistant, Halogen free Individually screened Instrument Cable (Code : 250V SFOU(I)[S112], SFOU(I/C))

No. of pair	No. of core	Part no.	Conductor		Thickness of insulation	Thickness of inner covering	Nominal dia. over inner covering	Dia. of metal wire for braid	Thickness of outer sheath	Nominal overall dia.	Cable weight approx	Conductor resistance (20°C)
			Nominal sectional area	Max. overall dia.								
Pr	EA	QSTA/QSSA	mm ²	mm	mm	mm	mm	mm	mm	kg/km	Ω /km	
1	2	01P001	1.0	1.4	0.6	1.0	7.0	0.2	1.1	10.1±0.6	165	19.3
2	4	02P001	1.0	1.4	0.6	1.0	10.9	0.3	1.3	14.9±0.6	350	19.3
3	6	03P001	1.0	1.4	0.6	1.0	11.4	0.3	1.3	15.4±0.6	405	19.3
4	8	04P001	1.0	1.4	0.6	1.0	12.3	0.3	1.3	16.3±0.6	470	19.3
5	10	05P001	1.0	1.4	0.6	1.0	13.6	0.3	1.4	17.8±0.6	555	18.2
6	12	06P001	1.0	1.4	0.6	1.0	14.9	0.3	1.5	19.3±0.6	635	19.3
7	14	07P001	1.0	1.4	0.6	1.0	14.9	0.3	1.5	19.3±0.6	675	19.3
8	16	08P001	1.0	1.4	0.6	1.0	16.4	0.3	1.5	20.8±0.6	765	19.3
9	18	09P001	1.0	1.4	0.6	1.0	17.5	0.3	1.6	22.1±0.6	845	19.3
10	20	10P001	1.0	1.4	0.6	1.0	18.4	0.3	1.6	23.0±0.6	910	19.3
12	24	12P001	1.0	1.4	0.6	1.0	19.0	0.3	1.6	23.6±0.6	1,015	18.2
14	28	14P001	1.0	1.4	0.6	1.0	20.0	0.3	1.7	24.8±0.6	1,140	19.3
15	30	15P001	1.0	1.4	0.6	1.0	21.6	0.3	1.7	26.4±1.1	1,240	19.3
16	32	16P001	1.0	1.4	0.6	1.0	22.0	0.3	1.7	26.8±1.1	1,290	19.3
18	36	18P001	1.0	1.4	0.6	1.0	23.2	0.3	1.8	28.2±1.1	1,430	19.3
19	38	19P001	1.0	1.4	0.6	1.0	23.5	0.3	1.8	28.5±1.1	1,460	19.3
20	40	20P001	1.0	1.4	0.6	1.0	24.6	0.3	1.8	29.6±1.2	1,555	19.3
21	42	21P001	1.0	1.4	0.6	1.0	25.3	0.3	1.9	30.5±1.2	1,630	19.3
23	46	23P001	1.0	1.4	0.6	1.0	25.8	0.3	1.9	31.0±1.2	1,735	19.3
24	48	24P001	1.0	1.4	0.6	1.2	27.5	0.3	2.0	32.9±1.3	1,810	19.3
27	54	27P001	1.0	1.4	0.6	1.2	28.1	0.3	2.0	33.5±1.3	1,990	19.3
30	60	30P001	1.0	1.4	0.6	1.2	29.2	0.3	2.0	34.6±1.4	2,175	19.3
32	64	32P001	1.0	1.4	0.6	1.2	30.0	0.3	2.1	35.6±1.4	2,300	19.3
37	74	37P001	1.0	1.4	0.6	1.2	31.5	0.4	2.1	37.5±1.5	2,645	19.3
1	2	01P015	1.5	1.7	0.7	1.0	8.0	0.2	1.2	11.3±0.6	200	12.9
2	4	02P015	1.5	1.7	0.7	1.0	12.5	0.3	1.4	16.7±0.6	425	12.9
3	6	03P015	1.5	1.7	0.7	1.0	13.2	0.3	1.4	17.4±0.6	505	12.9
4	8	04P015	1.5	1.7	0.7	1.0	14.3	0.3	1.4	18.5±0.6	600	12.9
5	10	05P015	1.5	1.7	0.7	1.0	15.7	0.3	1.5	20.1±0.6	705	12.9
6	12	06P015	1.5	1.7	0.7	1.0	17.3	0.3	1.5	21.7±0.6	815	12.9
7	14	07P015	1.5	1.7	0.7	1.0	17.3	0.3	1.5	21.7±0.6	865	12.9
8	16	08P015	1.5	1.7	0.7	1.0	19.0	0.3	1.6	23.6±0.6	990	12.9
9	18	09P015	1.5	1.7	0.7	1.0	20.4	0.3	1.7	25.2±1.0	1,100	12.9
10	20	10P015	1.5	1.7	0.7	1.0	21.5	0.3	1.7	26.3±1.1	1,175	12.9
12	24	12P015	1.5	1.7	0.7	1.0	22.1	0.3	1.7	26.9±1.1	1,320	12.9
14	28	14P015	1.5	1.7	0.7	1.0	23.4	0.3	1.8	28.4±1.1	1,495	12.9
15	30	15P015	1.5	1.7	0.7	1.0	25.2	0.3	1.9	30.4±1.2	1,615	12.9
16	32	16P015	1.5	1.7	0.7	1.0	25.7	0.3	1.9	30.9±1.2	1,695	12.9
18	36	18P015	1.5	1.7	0.7	1.2	27.5	0.3	2.0	32.9±1.3	1,870	12.9
19	38	19P015	1.5	1.7	0.7	1.2	27.8	0.3	2.0	33.2±1.3	1,930	12.9
20	40	20P015	1.5	1.7	0.7	1.2	29.1	0.3	2.0	34.5±1.4	2,075	12.9
21	42	21P015	1.5	1.7	0.7	1.2	30.0	0.3	2.1	35.6±1.4	2,175	12.9
23	46	23P015	1.5	1.7	0.7	1.2	30.5	0.4	2.1	36.5±1.5	2,305	12.9
24	48	24P015	1.5	1.7	0.7	1.2	32.2	0.4	2.2	38.4±1.5	2,495	12.9
27	54	27P015	1.5	1.7	0.7	1.2	32.9	0.4	2.2	39.1±1.6	2,725	12.9
30	60	30P015	1.5	1.7	0.7	1.2	34.2	0.4	2.2	40.4±1.6	2,960	12.9
32	64	33P015	1.5	1.7	0.7	1.2	35.2	0.4	2.3	41.6±1.7	3,130	12.9
37	74	37P015	1.5	1.7	0.7	1.2	36.9	0.4	2.3	43.3±1.7	3,495	12.9

Example) 250V SFOU(I) 1Pr x 1.5mm² Part No. QSSA01P015

Q NEK606	S SFOU(I)	S Fire resistant (SR)	A 150/250V	01P No. of Pair	015 Size (mm ²)
--------------------	---------------------	---------------------------------	----------------------	---------------------------	---------------------------------------

High Voltage Flame Retardant Cable

High Voltage Flame & Fire Resistant Cable

Low Voltage Flame Retardant Cable

Low Voltage Flame & Fire Resistant Cable

Technical information

250V Armored Flame retardant, Halogen free Individually screened Instrument Cable (Code : 250V RFOU(I)[S101], RFOU(I/C))

250V Armored Flame & Fire resistant, Halogen free Individually screened Instrument Cable (Code : 250V SFOU(I)[S112], SFOU(I/C))

No. of pair	No. of core	Part no.	Conductor		Thickness of insulation	Thickness of inner covering	Nominal dia. over inner covering	Dia. of metal wire for braid	Thickness of outer sheath	Nominal overall dia.	Cable weight approx	Conductor resistance (20°C)
			Nominal sectional area	Max. overall dia.								
Pr	EA	QSTA	mm ²	mm	mm	mm	mm	mm	mm	mm	kg/km	Ω /km
1	2	01P025	2.5	2.2	0.7	1.0	8.8	0.2	1.2	12.1±0.6	240	8.02
2	4	02P025	2.5	2.2	0.7	1.0	13.9	0.3	1.4	18.1±0.6	520	8.02
3	6	03P025	2.5	2.2	0.7	1.0	14.6	0.3	1.4	18.8±0.6	625	8.02
4	8	04P025	2.5	2.2	0.7	1.0	15.8	0.3	1.5	20.2±0.6	750	8.02
5	10	05P025	2.5	2.2	0.7	1.0	17.5	0.3	1.6	22.1±0.6	885	8.02
6	12	06P025	2.5	2.2	0.7	1.0	19.2	0.3	1.6	23.8±0.6	1,040	8.02
7	14	07P025	2.5	2.2	0.7	1.0	19.2	0.3	1.6	23.8±0.6	1,110	8.02
8	16	08P025	2.5	2.2	0.7	1.0	21.2	0.3	1.7	26.0±1.0	1,270	8.02
9	18	09P025	2.5	2.2	0.7	1.0	22.7	0.3	1.8	27.7±1.1	1,410	8.02
10	20	10P025	2.5	2.2	0.7	1.0	23.9	0.3	1.8	28.9±1.2	1,515	8.02
12	24	12P025	2.5	2.2	0.7	1.0	24.7	0.3	1.8	29.7±1.2	1,710	8.02
14	28	14P025	2.5	2.2	0.7	1.0	26.1	0.3	1.9	31.3±1.3	1,945	8.02
15	30	15P025	2.5	2.2	0.7	1.2	28.4	0.3	2.0	33.8±1.4	2,140	8.02
16	32	16P025	2.5	2.2	0.7	1.2	29.0	0.3	2.0	34.4±1.4	2,235	8.02
18	36	18P025	2.5	2.2	0.7	1.2	30.6	0.4	2.1	36.6±1.5	2,485	8.02
19	38	19P025	2.5	2.2	0.7	1.2	31.0	0.4	2.1	37.0±1.5	2,615	8.02
20	40	20P025	2.5	2.2	0.7	1.2	32.4	0.4	2.2	38.6±1.5	2,790	8.02
21	42	21P025	2.5	2.2	0.7	1.2	33.5	0.4	2.2	39.7±1.6	2,945	8.02
23	46	23P025	2.5	2.2	0.7	1.2	34.0	0.4	2.2	40.2±1.6	3,120	8.02
24	48	24P025	2.5	2.2	0.7	1.4	35.9	0.4	2.3	42.3±1.7	3,275	8.02
27	54	27P025	2.5	2.2	0.7	1.4	36.8	0.4	2.3	43.2±1.7	3,570	8.02
30	60	30P025	2.5	2.2	0.7	1.4	38.5	0.4	2.4	45.1±1.8	3,945	8.02
32	64	32P025	2.5	2.2	0.7	1.4	39.6	0.4	2.5	46.4±1.9	4,175	8.02
37	74	37P025	2.5	2.2	0.7	1.4	41.6	0.4	2.5	48.4±1.9	4,670	8.02

Example) 250V RFOU(I) 1Pr x 2.5mm² Part No. QSTA01P025

Q	S	T	A	01P	025
NEK606	RFOU(I)	Flame retardant	150/250V	No. of Pair	Size (mm ²)

250V Armored Flame retardant, Halogen free Individually screened Instrument Cable (Code : 250V RFOU(I)[S101], RFOU(I/C))
250V Armored Flame & Fire resistant, Halogen free Individually screened Instrument Cable (Code : 250V SFOU(I)[S112], SFOU(I/C))

No. of Triad	No. of core	Part no.	Conductor		Thickness of insulation	Thickness of inner covering	Nominal dia. over inner covering	Dia. of metal wire for braid	Thickness of outer sheath	Nominal overall dia.	Cable weight approx	Conductor resistance (20°C)
			Nominal sectional area	Max. overall dia.								
Tr	EA	QSTA/QSSA	mm ²	mm	mm	mm	mm	mm	mm	mm	kg/km	Ω /km
1	3	01T075	0.75	1.2	0.6	1.0	7.2	0.2	1.1	10.3±0.6	170	26.3
2	6	02T075	0.75	1.2	0.6	1.0	11.5	0.3	1.3	15.5±0.6	370	26.3
3	9	03T075	0.75	1.2	0.6	1.0	12.0	0.3	1.3	16.0±0.6	430	26.3
4	12	04T075	0.75	1.2	0.6	1.0	13.1	0.3	1.4	17.3±0.6	515	26.3
5	15	05T075	0.75	1.2	0.6	1.0	14.4	0.3	1.4	18.6±0.6	595	26.3
6	18	06T075	0.75	1.2	0.6	1.0	16.2	0.3	1.5	20.6±0.6	700	26.3
7	21	07T075	0.75	1.2	0.6	1.0	16.2	0.3	1.5	20.6±0.6	740	26.3
8	24	08T075	0.75	1.2	0.6	1.0	17.5	0.3	1.6	22.1±0.6	825	26.3
9	27	09T075	0.75	1.2	0.6	1.0	18.8	0.3	1.6	23.4±0.6	930	26.3
10	30	10T075	0.75	1.2	0.6	1.0	20.4	0.3	1.7	25.2±1.0	1,000	26.3
12	36	12T075	0.75	1.2	0.6	1.0	21.1	0.3	1.7	25.9±1.0	1,130	26.3
14	42	14T075	0.75	1.2	0.6	1.0	22.2	0.3	1.7	27.0±1.1	1,260	26.3
15	45	15T075	0.75	1.2	0.6	1.0	23.0	0.3	1.8	28.0±1.1	1,340	26.3
16	48	16T075	0.75	1.2	0.6	1.0	23.7	0.3	1.8	28.7±1.1	1,415	26.3
18	54	18T075	0.75	1.2	0.6	1.0	25.0	0.3	1.9	30.2±1.2	1,555	26.3
19	57	19T075	0.75	1.2	0.6	1.0	25.3	0.3	1.9	30.5±1.2	1,585	26.3
20	60	20T075	0.75	1.2	0.6	1.0	26.1	0.3	1.9	31.3±1.3	1,700	26.3
21	63	21T075	0.75	1.2	0.6	1.2	27.0	0.3	1.9	32.2±1.3	1,775	26.3
23	69	23T075	0.75	1.2	0.6	1.2	28.2	0.3	2.0	33.6±1.3	1,915	26.3
24	72	24T075	0.75	1.2	0.6	1.2	28.7	0.3	2.0	34.1±1.4	1,990	26.3
27	81	27T075	0.75	1.2	0.6	1.2	30.3	0.4	2.1	36.3±1.5	2,180	26.3
30	90	30T075	0.75	1.2	0.6	1.2	31.8	0.4	2.1	37.8±1.5	2,470	26.3
32	96	32T075	0.75	1.2	0.6	1.2	32.8	0.4	2.2	39.0±1.6	2,610	26.3
1	3	01T001	1.0	1.4	0.6	1.0	7.4	0.2	1.1	10.5±0.6	185	19.3
2	6	02T001	1.0	1.4	0.6	1.0	11.9	0.3	1.3	15.9±0.6	400	19.3
3	9	03T001	1.0	1.4	0.6	1.0	12.4	0.3	1.4	16.6±0.6	465	19.3
4	12	04T001	1.0	1.4	0.6	1.0	13.5	0.3	1.4	17.7±0.6	560	19.3
5	15	05T001	1.0	1.4	0.6	1.0	14.9	0.3	1.5	19.3±0.6	655	19.3
6	18	06T001	1.0	1.4	0.6	1.0	16.8	0.3	1.5	21.2±0.6	765	19.3
7	21	07T001	1.0	1.4	0.6	1.0	16.8	0.3	1.5	21.2±0.6	815	19.3
8	24	08T001	1.0	1.4	0.6	1.0	18.1	0.3	1.6	22.7±0.6	930	19.3
9	27	09T001	1.0	1.4	0.6	1.0	19.5	0.3	1.6	24.1±0.6	1,030	19.3
10	30	10T001	1.0	1.4	0.6	1.0	21.1	0.3	1.7	25.9±1.0	1,120	19.3
12	36	12T001	1.0	1.4	0.6	1.0	21.9	0.3	1.7	26.7±1.1	1,255	19.3
14	42	14T001	1.0	1.4	0.6	1.0	23.0	0.3	1.8	28.0±1.1	1,405	19.3
15	45	15T001	1.0	1.4	0.6	1.0	23.8	0.3	1.8	28.8±1.2	1,510	19.3
16	48	16T001	1.0	1.4	0.6	1.0	24.6	0.3	1.8	29.6±1.2	1,580	19.3
18	54	18T001	1.0	1.4	0.6	1.0	25.9	0.3	1.9	31.1±1.2	1,750	19.3
19	57	19T001	1.0	1.4	0.6	1.0	26.2	0.3	1.9	31.4±1.3	1,790	19.3
20	60	20T001	1.0	1.4	0.6	1.2	27.3	0.3	1.9	32.5±1.3	1,900	19.3
21	63	21T001	1.0	1.4	0.6	1.2	27.9	0.3	2.0	33.3±1.3	2,010	19.3
23	69	23T001	1.0	1.4	0.6	1.2	29.2	0.3	2.0	34.6±1.4	2,165	19.3
24	72	24T001	1.0	1.4	0.6	1.2	29.7	0.3	2.0	35.1±1.4	2,230	19.3
27	81	27T001	1.0	1.4	0.6	1.2	31.4	0.4	2.1	37.4±1.5	2,545	19.3
30	90	30T001	1.0	1.4	0.6	1.2	33.0	0.4	2.2	39.2±1.6	2,770	19.3
32	96	32T001	1.0	1.4	0.6	1.2	34.0	0.4	2.2	40.2±1.6	2,950	19.3

Example) 250V RFOU(I) 1Tr x 0.75mm² Part No. QSTA01T075

Q NEK606	S RFOU(I)	T Flame retardant	A 150/250V	01T No. of Triad	075 Size (mm ²)
--------------------	---------------------	-----------------------------	----------------------	----------------------------	---------------------------------------

High Voltage Flame Retardant Cable

High Voltage Flame & Fire Resistant Cable

Low Voltage Flame Retardant Cable

Low Voltage Flame & Fire Resistant Cable

Technical information

250V Armored Flame retardant, Halogen free Individually screened Instrument Cable (Code : 250V RFOU(I)[S101], RFOU(I/C))

250V Armored Flame & Fire resistant, Halogen free Individually screened Instrument Cable (Code : 250V SFOU(I)[S112], SFOU(I/C))

No. of Triad	No. of core	Part no.	Conductor		Thickness of insulation	Thickness of inner covering	Nominal dia. over inner covering	Dia. of metal wire for braid	Thickness of outer sheath	Nominal overall dia.	Cable weight approx	Conductor resistance (20°C)
			Nominal sectional area	Max. overall dia.								
Tr	EA	QSTA/QSSA	mm ²	mm	mm	mm	mm	mm	mm	mm	kg/km	Ω /km
1	3	01T015	1.5	1.7	0.7	1.0	8.5	0.2	1.2	11.8±0.6	230	12.9
2	6	02T015	1.5	1.7	0.7	1.0	13.7	0.3	1.4	17.9±0.6	500	12.9
3	9	03T015	1.5	1.7	0.7	1.0	14.4	0.3	1.4	18.6±0.6	595	12.9
4	12	04T015	1.5	1.7	0.7	1.0	15.7	0.3	1.5	20.1±0.6	720	12.9
5	15	05T015	1.5	1.7	0.7	1.0	17.3	0.3	1.5	21.7±0.6	845	12.9
6	18	06T015	1.5	1.7	0.7	1.0	19.5	0.3	1.6	24.1±0.6	1,000	12.9
7	21	07T015	1.5	1.7	0.7	1.0	19.5	0.3	1.6	24.1±0.6	1,070	12.9
8	24	08T015	1.5	1.7	0.7	1.0	21.1	0.3	1.7	25.9±1.0	1,215	12.9
9	27	09T015	1.5	1.7	0.7	1.0	22.7	0.3	1.8	27.7±1.1	1,350	12.9
10	30	10T015	1.5	1.7	0.7	1.0	24.7	0.3	1.8	29.7±1.2	1,460	12.9
12	36	12T015	1.5	1.7	0.7	1.2	25.6	0.3	1.9	30.8±1.2	1,650	12.9
14	42	14T015	1.5	1.7	0.7	1.2	27.2	0.3	1.9	32.4±1.3	1,870	12.9
15	45	15T015	1.5	1.7	0.7	1.2	28.1	0.3	2.0	33.5±1.3	2,020	12.9
16	48	16T015	1.5	1.7	0.7	1.2	29.1	0.3	2.0	34.5±1.4	2,130	12.9
18	54	18T015	1.5	1.7	0.7	1.2	30.7	0.4	2.1	36.7±1.5	2,355	12.9
19	57	19T015	1.5	1.7	0.7	1.2	31.0	0.4	2.1	37.0±1.5	2,495	12.9
20	60	20T015	1.5	1.7	0.7	1.2	32.0	0.4	2.2	38.2±1.5	2,650	12.9
21	63	21T015	1.5	1.7	0.7	1.2	32.7	0.4	2.2	38.9±1.6	2,770	12.9
23	69	23T015	1.5	1.7	0.7	1.2	34.1	0.4	2.2	40.3±1.6	2,980	12.9
24	72	24T015	1.5	1.7	0.7	1.2	34.8	0.4	2.3	41.2±1.6	3,075	12.9
27	81	27T015	1.5	1.7	0.7	1.2	36.8	0.4	2.3	43.2±1.7	3,400	12.9
30	90	30T015	1.5	1.7	0.7	1.4	39.0	0.4	2.4	45.6±1.8	3,765	12.9
32	96	32T015	1.5	1.7	0.7	1.4	40.2	0.4	2.5	47.0±1.9	3,990	12.9
1	3	01T025	2.5	2.2	0.7	1.0	9.3	0.2	1.2	12.6±0.6	275	8.02
2	6	02T025	2.5	2.2	0.7	1.0	15.2	0.3	1.5	19.6±0.6	620	8.02
3	9	03T025	2.5	2.2	0.7	1.0	15.9	0.3	1.5	20.3±0.6	755	8.02
4	12	04T025	2.5	2.2	0.7	1.0	17.4	0.3	1.6	22.0±0.6	905	8.02
5	15	05T025	2.5	2.2	0.7	1.0	19.2	0.3	1.6	23.8±0.6	1,090	8.02
6	18	06T025	2.5	2.2	0.7	1.0	21.7	0.3	1.7	26.5±1.1	1,290	8.02
7	21	07T025	2.5	2.2	0.7	1.0	21.7	0.3	1.7	26.5±1.1	1,385	8.02
8	24	08T025	2.5	2.2	0.7	1.0	23.5	0.3	1.8	28.5±1.1	1,575	8.02
9	27	09T025	2.5	2.2	0.7	1.0	25.3	0.3	1.9	30.5±1.2	1,760	8.02
10	30	10T025	2.5	2.2	0.7	1.2	27.8	0.3	2.0	33.2±1.3	1,935	8.02
12	36	12T025	2.5	2.2	0.7	1.2	28.8	0.3	2.0	34.2±1.4	2,210	8.02
14	42	14T025	2.5	2.2	0.7	1.2	30.3	0.4	2.1	36.3±1.5	2,495	8.02
15	45	15T025	2.5	2.2	0.7	1.2	31.4	0.4	2.1	37.4±1.5	2,755	8.02
16	48	16T025	2.5	2.2	0.7	1.2	32.4	0.4	2.2	38.6±1.5	2,890	8.02
18	54	18T015	2.5	2.2	0.7	1.2	34.2	0.4	2.2	40.4±1.6	3,215	8.02
19	57	19T025	2.5	2.2	0.7	1.2	34.6	0.4	2.3	41.0±1.6	3,290	8.02
20	60	20T025	2.5	2.2	0.7	1.2	35.7	0.4	2.3	42.1±1.7	3,520	8.02
21	63	21T025	2.5	2.2	0.7	1.2	36.5	0.4	2.3	42.9±1.7	3,685	8.02
23	69	23T025	2.5	2.2	0.7	1.4	38.4	0.4	2.4	45.0±1.8	3,995	8.02
24	72	24T025	2.5	2.2	0.7	1.4	39.2	0.4	2.4	45.8±1.8	4,130	8.02
27	81	27T025	2.5	2.2	0.7	1.4	41.4	0.4	2.5	48.2±1.9	4,575	8.02
30	90	30T025	2.5	2.2	0.7	1.4	43.5	0.4	2.6	50.5±2.0	5,030	8.02
32	96	32T025	2.5	2.2	0.7	1.4	44.9	0.4	2.7	52.1±2.1	5,330	8.02

Example) 250V SFOU(I) 1Tr x 1.5mm² Part No. QSSA01T015

Q NEK606	S SFOU(I)	S Fire resistant (SR)	A 150/250V	01T No. of Triad	015 Size (mm ²)
--------------------	---------------------	---------------------------------	----------------------	----------------------------	---------------------------------------

LV CABLE

Single wire, Halogen free cable (0.6/1kV RX) Halogen free Earthing wire (0.6/1kV UX)



Application

- Power circuit below 1kV
- Fixed installation for earthing, bonding services, panels and control desks, etc. on general purpose.
- Maximum operating conductor temperature 90°C

Construction Details

1 Conductor : Circular tinned stranded copper as per IEC 60228 Class 2 or Class 5

2 Insulation/Sheath

Code-RX

Halogen-free Ethylene propylene rubber insulation as per IEC 60092-360, EPR

Code-UX

Halogen-free thermoset compound sheath as per IEC 60092-360, SHF2

Standards Applied

- **Design guideline** : IEC 60092-353, NEK 606
- **Material properties** :
 - Code-RX : IEC 60092-360 Insulation (EPR)
 - Code-Ux : IEC 60092-360 Sheath (SHF2)
- **Flame retardant** : IEC 60332-3, Cat. 'A'
- **Assessment of halogen** : IEC 60754-1/2 & 60684-2
- **Low smoke properties** : IEC 61034-1/2
- **Sunlight resistance** : UL 1581
- **Cold properties(option)** : CSA C22.2 No. 03. Cold bending(-50°C), Cold impact(-50°C)
- **Oil/Mud resistance(option)** : NEK TS 606 5th ed (Category a, b, c, d)

Identification of color

- **Insulation** : Green/Yellow stripe(Code : UX)

Blue, Brown, Black or Grey(Code : RX)

Note) The any other identification of color may be applicable when purchaser required

Approvals



-35 to 90°C



Flame retardant
IEC 60332-3



Cold impact
CSA C22.2 No.38, -65°C
Special requirement



Halogen free



Weather
Resistance to severe
weather conditions



Chemical attacks
Resistance to
chemicals



Smoke-Corrosivity-Toxicity
Smoke density, gases corrosivity and toxicity

High Voltage Flame
Retardant Cable

High Voltage Flame
& Fire Resistant Cable

Low Voltage Flame
Retardant Cable

Low Voltage Flame
& Fire Resistant Cable

Technical information

0.6/1kV Single wire, Halogen free cable(Code : 0.6/1kV RX[S111])

0.6/1kV Halogen free earth wire (Code : 0.6/1kV UX[P108])

No. of core	Part no.	Conductor			Thickness of insulation	Nominal overall dia.	Cable weight approx.	Conductor resistance (20°C)	Current rating at 45°C
		Nominal sectional area	Min. No. of wires	Max. overall dia.					
EA	QBTDG	mm ²	EA	mm	mm	mm	kg/km	Ω /km	Amp.
1	01C001	1.0	7	1.4	2.0	5.3	45	18.2	18
	01C015	1.5	7	1.7	2.0	5.6	55	12.2	23
	01C025	2.5	7	2.2	2.0	6.0	65	7.56	30
	01C004	4	7	2.7	2.0	6.5	85	4.70	40
	01C006	6	7	3.3	2.0	7.1	105	3.11	52
	01C010	10	7	4.2	2.0	8.0	150	1.84	72
	01C016	16	7	5.3	2.1	9.2	220	1.16	96
	01C025	25	7	6.6	2.3	10.9	330	0.734	127
	01C035	35	7	7.9	2.4	12.2	430	0.529	157
	01C050	50	19	9.1	2.7	14.3	585	0.391	196
	01C070	70	19	11.0	2.7	16.0	790	0.270	242
	01C095	95	19	12.9	3.0	18.4	1,065	0.195	293
	01C120	120	37	14.5	3.1	20.3	1,340	0.154	339
	01C150	150	37	16.2	3.4	22.5	1,650	0.126	389
	01C185	185	37	18.0	3.7	24.7	2,000	0.1000	444
	01C240	240	61	20.6	4.0	28.2	2,650	0.0762	522
01C300	300	61	23.1	4.3	30.9	3,215	0.0607	601	

Example) **0.6/1kV UX1C x 1.0mm²** Part No. **QBTD01C001**

Q NEK606	B UX	T Flame retardant	D 0.6/1kV	01C No. of Pair	001 Size (mm ²)
--------------------	----------------	-----------------------------	---------------------	---------------------------	---------------------------------------

VFD CABLE

Armored Flame Retardant, Halogen free VFD Cables (RFOU-EMC) Armored Flame & Fire resistant, Halogen free VFD Cables (BFOU-EMC)

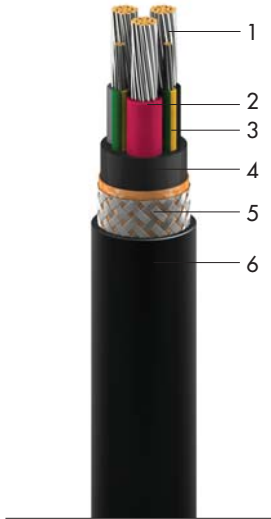

Application

- Power circuit below 1kV,(or 3kV) Motor Power circuit for PWM AC Drives.
- Fixed installation power in both explosion risk and safe areas, general purpose.
- Maximum operating conductor temperature 90°C

Construction Details

- 1 Conductor** : Circular tinned stranded copper as per IEC 60228, Class 2 or Class5
- 2 Insulation** : Halogen Free Ethylene Propylene Rubber (EPR)as per IEC 60092-360
Fire proof layer/ Halogen Free Ethylene Propylene Rubber (EPR)as per IEC 60092-360
- 3 Cabling** (with filler)
- 4 Inner covering** : Halogen-free thermosetting compound
- 5 Armor(screen)** : Cu/PS tape & Copper wire braid combination 100% shield screen.
- 6 Outer sheath** : Halogen-free thermosetting compound as per IEC 60092-360, SHF2 or SHF2 Oil & Mud

Standards Applied

- **Design guideline** : IEC 60092-353, IEEE 1580
- **Material properties** : IEC 60092-360, Insulation (EPR)
IEC 60092-360, Sheath (SHF2)
- **Flame retardant** : IEC 60332-3, Cat. 'A'
- **Fire resistant(BFOU)**: IEC 60331-1/2, at 830°C for 120 min.
- **Assessment of halogen** : IEC 60754-1/-2 & 60684-2
- **Low smoke properties** : IEC 61034-1/2
- **Sunlight resistance** : UL 1581
- **Cold properties(option)** : CSA C22.2 No. 03, Cold bending(-50°C),Cold impact(-50°C)
- **Oil/Mud resistance(option)** : NEK TS 606 5th ed (Category a, b, c, d)

Identification of color

- **Insulation**
 - 3C : Grey(off white),Black, Red
 - Earthing : Green/Yellow stripe
- **Outer sheath** : Black

Note) The any other identification of color may be applicable when purchaser required

Approvals

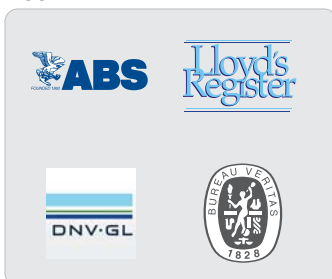

-35 to 90°C



Flame & Fire resistant
IEC 60332-3 A
& IEC 60331



Cold impact
CSA C22.2 No.38, -65°C
Special requirement



Halogen free



Weather
Resistance to severe
weather conditions



Chemical attacks
Resistance to
chemicals



Smoke-Corrosivity-Toxicity
Smoke density, gases corrosivity and toxicity



Resistance to Mud
NEK TS 606



Resistance to
Enhanced oil &
Hydraulic/gear oil

High Voltage Flame
Retardant Cable

High Voltage Flame
& Fire Resistant Cable

Low Voltage Flame
Retardant Cable

Low Voltage Flame
& Fire Resistant Cable

Technical information

0.6/1kV Armored Flame retardant, Halogen free VFD Cable (Code : 0.6/1kV RFOU-EMC)

No. of core	Part no.	Conductor		Thickness of insulation	Thickness of inner covering	Nominal dia. over inner covering	Dia. of metal wire for braid	Thickness of outer sheath	Nominal overall dia.	Cable weight approx	Conductor resistance (20°C)	Current rating at 45°C
		Nominal sectional area	Max. overall dia.									
EA	QXTD	mm ²	mm	mm	mm	mm	mm	mm	mm	kg/km	Ω/km	Amp.
3	03C025	2.5/4	2.2	1.0	1.0	10.5	0.3	1.3	14.5±0.6	355	7.56	21
	03C004	4/4	2.7	1.0	1.0	11.6	0.3	1.3	15.6±0.6	425	4.70	28
	03C006	6/6	3.3	1.0	1.0	12.9	0.3	1.4	17.1±0.7	525	3.11	36
	03C010	10/10	4.2	1.0	1.0	14.8	0.3	1.4	19.0±0.8	690	1.84	50
	03C016	16/16	5.3	1.0	1.0	17.0	0.3	1.5	18.4±0.9	935	1.16	67
	03C025	25/16	6.6	1.2	1.0	20.6	0.3	1.7	25.4±1.0	1355	0.734	89
	03C035	35/16	7.9	1.2	1.0	23.0	0.3	1.8	28.0±1.2	1705	0.529	110
	03C050	50/25	9.1	1.4	1.2	27.4	0.3	2.0	32.8±1.3	2290	0.391	137
	03C070	70/70	11.0	1.4	1.2	31.1	0.4	2.1	37.1±1.5	3110	0.270	169
	03C095	95/50	12.9	1.6	1.2	35.8	0.4	2.3	42.2±1.7	4075	0.195	205
	03C120	120	14.5	1.6	1.4	39.8	0.4	2.5	46.6±1.9	5065	0.154	237
	03C150	150	16.2	1.8	1.4	44.1	0.4	2.6	51.1±2.0	6145	0.126	272
	03C185	185	18.0	2.0	1.6	48.8	0.4	2.8	56.2±2.2	7430	0.1000	311
	03C240	240	20.6	2.2	1.6	55.9	0.4	3.1	63.9±2.6	9735	0.0762	365
	03C300	300	23.1	2.4	1.6	61.3	0.4	3.3	69.7±2.8	11695	0.0607	421
	03C120*	120/*60	14.5	1.6	1.4	39.8	*0.4 ^{1/2}	2.5	48.4±1.9	5540	0.154	237
	03C150*	150/*75	16.2	1.8	1.4	44.1	*0.4 ^{1/2}	2.7	53.1±2.1	6695	0.126	272
	03C185*	185/*95	18.0	2.0	1.6	48.8	*0.4 ^{1/2}	2.9	58.7±2.3	8195	0.1000	311
03C240*	240/*120	20.6	2.2	1.6	55.9	*0.4 ^{1/2}	3.2	66.8±2.7	10750	0.0762	365	
3+3E	06E025	25	6.6	1.2	1.0	22.4	0.3	1.8	27.4±1.1	1620	0.734	89
		6E	3.3	1.0							3.11	
	06E035	35	7.9	1.2	1.0	25.6	0.3	1.9	30.8±1.2	2110	0.529	110
		10E	4.2	1.0							1.84	
	06E050	50	9.1	1.4	1.2	28.1	0.3	2.0	33.5±1.3	2645	0.393	137
		10E	4.2	1.0							1.95	
	06E070	70	11.0	1.4	1.2	32.1	0.4	2.2	38.3±1.5	3670	0.277	169
		16E	5.3	1.0							1.24	
	06E095	95	12.9	1.6	1.4	38.5	0.4	2.4	45.1±1.8	5010	0.21	205
		25E	6.6	1.2							0.795	
	06E120	120	14.5	1.6	1.4	40.5	0.4	2.5	47.3±1.9	5905	0.164	237
		25E	6.6	1.2							0.795	
	06E150	150	16.2	1.8	1.4	45.1	0.4	2.7	52.3±2.1	7285	0.132	272
		35E	7.9	1.2							0.565	
	06E185	185	18.0	2.0	1.6	48.8	0.4	2.8	56.2±2.2	8520	0.108	311
		35E	7.9	1.2							0.565	
	06E240	240	20.6	2.2	1.6	55.9	0.4	3.1	63.9±2.6	11240	0.0817	365
		50E	9.1	1.4							0.393	
	06E300	300	23.1	2.4	1.6	61.3	0.4	3.3	69.7±2.8	13195	0.0607	421
		50E	9.1	1.4							0.391	

Example) 0.6/1kV RFOU EMC 3C x 2.5mm² Part No. QXTD03C025

Note) "*" double braided(option)

Q NEK606	X VFD	T Flame retardant	D 0.6/1kV	03C No. of Core	025 Size (mm ²)
--------------------	-----------------	-----------------------------	---------------------	---------------------------	---------------------------------------

1.8/3kV Armored Flame retardant, Halogen free VFD Cable (Ccode : 1.8/3kV RFOU-EMC)

No. of core	Part no.	Conductor		Thickness of insulation	Thickness of inner covering	Nominal dia. over inner covering	Dia. of metal wire for braid	Thickness of outer sheath	Nominal overall dia.	Cable weight approx	Conductor resistance (20°C)	Current rating at 45°C
		Nominal sectional area	Max. overall dia.									
EA	QXTE	mm ²	mm	mm	mm	mm	mm	mm	mm	kg/km	Ω /km	Amp.
3C	03C010	10	4.2	2.2	1.0	20.0	0.3	1.7	24.8±1.0	965	1.84	50
	03C016	16	5.3	2.2	1.0	22.2	0.3	1.7	27.0±1.1	1,220	1.16	67
	03C025	25	6.6	2.2	1.0	25.0	0.3	1.9	30.2±1.2	1,625	0.734	89
	03C035	35	7.9	2.2	1.2	27.6	0.3	2.0	33.0±1.3	2,020	0.529	110
	03C050	50	9.1	2.2	1.2	30.9	0.4	2.1	36.9±1.5	2,625	0.391	137
	03C070	70	11.0	2.2	1.2	34.5	0.4	2.3	40.9±1.6	3,415	0.270	169
	03C095	95	12.9	2.4	1.4	39.6	0.4	2.5	46.4±1.9	4,455	0.195	205
	03C120	120	14.5	2.4	1.4	43.2	0.4	2.6	50.2±2.0	5,415	0.154	237
	03C150	150	16.2	2.4	1.4	46.7	0.4	2.7	53.9±2.2	6,435	0.126	272
	03C185	185	18.0	2.4	1.6	50.5	0.4	2.9	58.1±2.3	7,650	0.100	311
	03C240	240	20.6	2.4	1.6	56.8	0.4	3.1	64.8±2.6	9,845	0.0762	365
	03C300	300	23.1	2.4	1.6	61.3	0.4	3.3	69.7±2.8	11,695	0.0607	421
	03C120*	120/*60	14.5	2.4	1.4	39.8	*0.4 ^{1/2}	2.7	52.2±2.1	5,965	0.154	237
	03C150*	150/*75	16.2	2.4	1.4	44.1	*0.4 ^{1/2}	2.8	55.9±2.2	7,025	0.126	272
	03C185*	185/*95	18.0	2.4	1.6	48.8	*0.45 ^{1/2}	3.0	60.6±2.4	8,445	0.1000	311
	03C240*	240/*120	20.6	2.4	1.6	55.9	*0.5 ^{1/2}	3.3	67.9±2.7	10,905	0.0762	365

Example) 1.8/3kV RFOU EMC 3C x 10mm² Part No. QXTE03C010

Note) "*1/2" double braided(option)

Q	X	T	E	03C	010
NEK606	VFD	Flame retardant	1.8/3kV	No. of Core	Size (mm ²)

High Voltage Flame Retardant Cable

High Voltage Flame & Fire Resistant Cable

Low Voltage Flame Retardant Cable

Low Voltage Flame & Fire Resistant Cable

Technical information

1.8/3kV Armored Flame retardant, Halogen free VFD Cable (Code : 1.8/3kV RFOU-EMC)

No. of core	Part no.	Conductor		Thickness of insulation	Thickness of inner covering	Nominal dia. over inner covering	Dia. of metal wire for braid	Thickness of outer sheath	Nominal overall dia.	Cable weight approx	Conductor resistance (20°C)	Current rating at 45°C
		Nominal sectional area	Max. overall dia.									
EA	QXTE	mm ²	mm	mm	mm	mm	mm	mm	mm	kg/km	Ω/km	Amp.
3+3E	06E025	25	6.6	2.2	1.0	25.0	0.3	1.9	30.2±1.2	1865	0.734	89
		6E	3.3	1.0							3.11	
	06E035	35	7.9	2.2	1.2	28.2	0.3	2.0	33.6±1.3	2400	0.529	110
		10E	4.2	1.0							1.84	
	06E050	50	9.1	2.2	1.2	30.9	0.4	2.1	36.9±1.5	2990	0.393	137
		10E	4.2	1.0							1.95	
	06E070	70	11.0	2.2	1.2	34.5	0.4	2.3	40.9±1.6	3965	0.277	169
		16E	5.3	1.0							1.24	
	06E095	95	12.9	2.4	1.4	40.4	0.4	2.5	47.2±1.9	5340	0.21	205
		25E	6.6	1.2							0.795	
	06E120	120	14.5	2.4	1.4	43.2	0.4	2.6	50.2±2.0	6280	0.164	237
		25E	6.6	1.2							0.795	
	06E150	150	16.2	2.4	1.4	46.7	0.4	2.7	53.9±2.2	7575	0.132	272
		35E	7.9	1.2							0.565	
	06E185	185	18.0	2.4	1.6	50.5	0.4	2.9	58.1±2.3	8795	0.108	311
		35E	7.9	1.2							0.565	
	06E240	240	20.6	2.4	1.6	56.8	0.4	3.1	64.8±2.6	11415	0.817	365
		50E	9.1	1.4							0.393	
	06E300	300	23.1	2.4	1.6	61.3	0.4	3.3	69.7±2.8	13270	0.0607	421
		50E	9.1	1.4							0.391	

Example) 1.8/3kV RFOU-EMC (3C+3E) x 25mm² Part No. QXTE06E025

Q	X	T	E	06E	025
NEK606	RFOU	Flame retardant	1.8/3kV	No. of Core	Size (mm ²)

0.6/1kV Armored Flame retardant, Fire retardant & Halogen free VFD Cable (Code : 0.6/1kV BFOU-EMC)

No. of core	Part no.	Conductor		Thickness of insulation	Thickness of inner covering	Nominal dia. over inner covering	Dia. of metal wire for braid	Thickness of outer sheath	Nominal overall dia.	Cable weight approx	Conductor resistance (20°C)	Current rating at 45°C
		Nominal sectional area	Max. overall dia.									
EA	QXXD	mm ²	mm	mm	mm	mm	mm	mm	mm	kg/km	Ω /km	Amp.
3	03C025	2.5/6	2.2	1.0	1.0	12.2	0.3	1.3	16.2±0.6	420	7.56	21
	03C004	4/6	2.7	1.0	1.0	13.3	0.3	1.4	17.5±0.7	505	4.70	28
	03C006	6/6	3.3	1.0	1.0	14.6	0.3	1.4	18.8±0.8	600	3.11	36
	03C010	10/10	4.2	1.0	1.0	16.6	0.3	1.5	21.0±0.8	785	1.84	50
	03C016	16/16	5.3	1.0	1.0	18.7	0.3	1.6	23.3±0.9	1,035	1.16	67
	03C025	25/16	6.6	1.2	1.0	22.4	0.3	1.8	27.4±1.1	1,470	0.734	89
	03C035	35/25	7.9	1.2	1.0	24.7	0.3	1.8	29.7±1.2	1,810	0.529	110
	03C050	50/25	9.1	1.4	1.2	29.1	0.3	2.0	34.5±1.4	2,430	0.391	137
	03C070	70/35	11.0	1.4	1.2	32.8	0.4	2.2	39.0±1.6	3,280	0.270	169
	03C095	95/50	12.9	1.6	1.4	37.8	0.4	2.4	44.4±1.8	4,295	0.195	205
	03C120	120	14.5	1.6	1.4	41.5	0.4	2.5	48.3±1.9	5,260	0.154	237
	03C150	150	16.2	1.8	1.4	45.8	0.4	2.7	53.0±2.1	6,375	0.126	272
	03C185	185	18.0	2.0	1.6	50.5	0.4	2.9	58.1±2.3	7,685	0.1000	311
	03C240	240	20.6	2.2	1.6	57.6	0.4	3.2	65.8±2.6	10,035	0.0762	365
	03C300	300	23.1	2.4	1.8	63.3	0.4	3.4	71.9±2.9	12,065	0.0607	421
	03C120*	120/60*	14.5	1.6	1.4	41.5	*0.4 ^{1/2}	2.6	50.3±2.0	5,745	0.154	237
	03C150*	150/75*	16.2	1.8	1.4	45.8	*0.4 ^{1/2}	2.8	55.0±2.2	6,915	0.126	272
	03C185*	185/95*	18.0	2.0	1.6	50.5	*0.4 ^{1/2}	3.0	60.6±2.4	8,430	0.1000	311
	03C240*	240/120*	20.6	2.2	1.6	57.6	*0.4 ^{1/2}	3.3	68.7±2.7	11,025	0.0762	365
3+3E	06E025	25	7.0	1.2	1.0	25.0	0.3	1.9	30.2±1.2	1790	0.734	89
		6	7.0	1.0							3.11	
	06E035	35	7.0	1.2	1.2	28.4	0.3	2.0	33.8±1.4	2315	0.529	110
		10	7.0	1.0							1.84	
	06E050	50	19.0	1.4	1.2	30.7	0.4	2.1	36.7±1.5	2935	0.270	137
		10	7.0	1.0							1.16	
	06E070	70	19.0	1.4	1.2	34.7	0.4	2.3	41.1±1.6	3910	0.195	169
		16	7.0	1.0							0.734	
	06E095	95	19.0	1.6	1.4	41.0	0.4	2.5	47.8±1.9	5275	0.154	205
		25	7.0	1.2							0.734	
	06E120	120	37.0	1.6	1.4	43.0	0.4	2.6	50.0±2.0	6195	0.126	237
		25	7.0	1.2							0.529	
	06E150	150	37.0	1.8	1.4	48.0	0.4	2.8	55.4±2.2	7655	0.10	272
		35	7.0	1.2							0.529	
	06E185	185	37.0	2.0	1.6	50.5	0.4	2.9	58.1±2.3	8830	0.0762	311
		35	7.0	1.2							0.391	
	06E240	240	61.0	2.2	1.6	58.1	0.4	3.2	66.3±2.7	11635	0.0607	365
		50	19.0	1.4							0.391	
	06E300	300	61.0	2.4	1.8	63.3	0.4	3.4	71.9±2.9	13650	0.0607	421
5E		19.0	1.4	0.391								

Example) 0.6/1kV BFOU-EMC 3C x 1.5mm² Part No. QXXD03C015

Note) "*" double braided(option)

Q	X	X	D	03C	015
NEK606	VFD	Fire resistant	0.6/1kV	No. of Core	Size (mm ²)

High Voltage Flame Retardant Cable

High Voltage Flame & Fire Resistant Cable

Low Voltage Flame Retardant Cable

Low Voltage Flame & Fire Resistant Cable

Technical information

1.8/3kV Armored Flame retardant, Fire resistant & Halogen free VFD Cable (Code : 1.8/3kV BFOU-EMC)

No. of core	Part no.	Conductor		Thickness of insulation	Thickness of inner covering	Nominal dia. over inner covering	Dia. of metal wire for braid	Thickness of outer sheath	Nominal overall dia.	Cable weight approx	Conductor resistance (20°C)	Current rating at 45°C
		Nominal sectional area	Max. overall dia.									
EA	QXXE	mm ²	mm	mm	mm	mm	mm	mm	mm	kg/km	Ω/km	Amp.
3	03C010	10	4.2	2.2	1.0	21.7	0.3	1.7	26.5±1.1	1,075	1.84	50
	03C016	16	5.3	2.2	1.0	23.9	0.3	1.8	28.9±1.2	1,350	1.16	67
	03C025	25	6.6	2.2	1.2	27.0	0.3	1.9	32.2±1.3	1,775	0.734	89
	03C035	35	7.9	2.2	1.2	29.4	0.3	2.0	34.8±1.4	2,155	0.529	110
	03C050	50	9.1	2.2	1.2	32.6	0.4	2.2	38.8±1.6	2,805	0.391	137
	03C070	70	11.0	2.2	1.2	36.2	0.4	2.3	42.6±1.7	3,590	0.270	169
	03C095	95	12.9	2.4	1.4	41.3	0.4	2.5	48.1±1.9	4,645	0.195	205
	03C120	120	14.5	2.4	1.4	45.0	0.4	2.7	52.2±2.1	5,660	0.154	237
	03C150	150	16.2	2.4	1.6	48.8	0.4	2.8	56.2±2.2	6,740	0.126	272
	03C185	185	18.0	2.4	1.6	52.2	0.4	3.0	60.0±2.4	7,915	0.1000	311
	03C240	240	20.6	2.4	1.6	58.5	0.4	3.2	66.7±2.7	10,150	0.0762	365
	03C300	300	23.1	2.4	1.8	63.3	0.4	3.4	71.9±2.9	12,065	0.0607	421
	03C120*	120/60*	14.5	2.4	1.4	45.0	*0.4 ^{1/2}	2.7	54.0±2.2	6,160	0.154	237
	03C150*	150/75*	16.2	2.4	1.6	48.8	*0.4 ^{1/2}	2.9	58.2±2.3	7,310	0.126	272
	03C185*	185/95*	18.0	2.4	1.6	52.2	*0.45 ^{1/2}	3.1	62.5±2.5	8,685	0.1000	311
	03C240*	240/120*	20.6	2.4	1.6	58.5	*0.5 ^{1/2}	3.3	69.6±2.8	11,150	0.0762	365

Example) 1.8/3kV BFOU-EMC 3C x 2.5mm² Part No. F-QXXD03C025

Note) "*/2" double braided(option)

Q NEK606	X VFD	X Fire resistant	E 1.8/3kV	03C No. of Core	025 Size (mm ²)
--------------------	-----------------	----------------------------	---------------------	---------------------------	---------------------------------------

1.8/3kV Armed Flame retardant, Fire resistant Halogen free VFD Cable (Code : 1.8/3kV BFOU-EMC)

No. of core	Part no.	Conductor		Thickness of insulation	Thickness of inner covering	Nominal dia. over inner covering	Dia. of metal wire for braid	Thickness of outer sheath	Nominal overall dia.	Cable weight approx	Conductor resistance (20°C)	Current rating at 45°C
		Nominal sectional area	Max. overall dia.									
EA	QXXE	mm ²	mm	mm	mm	mm	mm	mm	mm	kg/km	Ω /km	Amp.
3+3E	06E025	25	6.6	2.2	1.2	27.7	0.3	2.0	33.1±1.3	2060	0.734	89
		6E	3.3	1.0							3.11	
	06E035	35	7.9	2.2	1.2	30.8	0.4	2.1	36.8±1.5	2660	0.529	110
		10E	4.2	1.0							1.84	
	06E050	50	9.1	2.2	1.2	32.6	0.4	2.2	38.8±1.6	3180	0.270	137
		10E	4.2	1.0							1.16	
	06E070	70	11	2.2	1.2	36.6	0.4	2.3	43.0±1.7	4160	0.195	169
		16E	5.3	1.0							0.734	
	06E095	95	12.9	2.4	1.4	42.9	0.4	2.6	49.9±2.0	5585	0.154	205
		25E	6.6	1.2							0.734	
	06E120	120	14.5	2.4	1.4	45.0	0.4	2.7	52.2±2.1	6530	0.126	237
		25E	6.6	1.2							0.529	
	06E150	150	16.2	2.4	1.6	49.4	0.4	2.8	56.8±2.3	7905	0.10	272
		35E	7.9	1.2							0.529	
	06E185	185	18.0	2.4	1.6	52.2	0.4	3.0	60.0±2.4	9060	0.0762	311
		35E	7.9	1.2							0.391	
	06E240	240	20.6	2.4	1.6	58.6	0.4	3.2	66.8±2.7	11735	0.0607	365
		50E	9.1	1.4							0.391	
	06E300	300	23.1	2.4	1.8	63.3	0.4	3.4	71.9±2.9	13650	0.0607	421
		50E	9.1	1.4							0.391	

Example) 1.8/3kV BFOU-EMC (3C+3E) x 25mm² Part No. QXXE06E025

Q	X	X	E	06E	025
NEK606	BFOU	Fire resistant	1.8/3kV	No. of Core	Size (mm ²)

High Voltage Flame Retardant Cable

High Voltage Flame & Fire Resistant Cable

Low Voltage Flame Retardant Cable

Low Voltage Flame & Fire Resistant Cable

Technical information



Application

- Power circuit below 1kV, Fire fighting circuits and safety systems.
- Fixed installation power, control & lighting in safe areas, emergency and critical systems.
- Maximum operating conductor temperature 90°C

Construction Details

- 1 Conductor** : Circular tinned stranded copper as per IEC 60228 class2 or class5
- 2 Insulation** : Mica tape and Halogen-free Ethylene propylene rubber (EPR) as per IEC 60092-360
- 3 Core assembly** : Cabled with non-hygroscopic fillers and the binder tape may be applicable
- 4 Outer Sheath** : Halogen-free thermoset compound as per IEC 60092-360, SHF2 or SHF2 Oil & Mud

Standards Applied

- **Design guideline** : IEC 60092-353, NEK606
- **Material properties** : IEC 60092-360, Insulation (EPR)
IEC 60092-360, Sheath (SHF2)
- **Flame retardant** : IEC 60332-3, Cat. 'A'
- **Fire resistant** : IEC 60331-1/2, at 830°C for 120 min.
(option) waterspray for 15min
- **Assessment of halogen** : IEC 60754-1/2 & 60684-2
- **Low smoke properties** : IEC 61034-1/2
- **Sunlight resistance** : UL 1581
- **Cold properties(option)** : CSA C22.2 No. 03. Cold bending(-50°C), Cold impact(-50°C)
- **Oil/Mud resistance(option)** : NEK TS 606 5th ed (Category a, b, c, d)

Identification of color

- **Insulation** : -1C : Grey (off-white)
-2C : Grey, Black
-3C : Grey, Black, Red
-4C : Grey, Black, Red, Blue
-5Core and above : By numbering on White colored insulation
-Earth core : Green/Yellow stripe
- **Outer sheath** : Black

Note) The any other identification of color may be applicable when purchaser required

Approvals

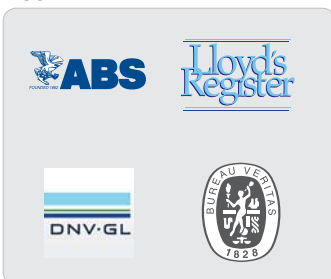

Flame & Fire resistant IEC 60332-3, A & IEC 60331
Cold impact CSA C22.2 No.38, -65°C Special requirement
Halogen free
Weather Resistance to severe weather conditions
Chemical attacks Resistance to chemicals



Smoke-Corrosivity-Toxicity
Smoke density, gases corrosivity and toxicity

0.6/1kV Unarmored Flame & Fire resistant, Halogen free Cable (Code : 0.6/1kV BU[P110])

No. of core	Part no.	Conductor			Thickness of insulation	Thickness of outer sheath	Nominal overall dia.	Cable weight approx.	Conductor resistance (20°C)	Current rating at 45°C
		Nominal sectional area	Min. No. of wires	Max. overall dia.						
EA	QCXD	mm ²	EA	mm	mm	mm	kg/km	Ω /km	Amp.	
1	01C001	1.0	7	1.4	1.0	1.0	6.1±0.6	60	18.2	18
	01C015	1.5	7	1.7	1.0	1.0	6.4±0.6	65	12.2	23
	01C025	2.5	7	2.2	1.0	1.0	6.8±0.6	80	7.56	30
	01C004	4	7	2.7	1.0	1.0	7.3±0.6	95	4.70	40
	01C006	6	7	3.3	1.0	1.0	7.9±0.6	120	3.11	52
	01C010	10	7	4.2	1.0	1.1	9.0±0.6	170	1.84	72
	01C016	16	7	5.3	1.0	1.1	10.0±0.6	235	1.16	96
	01C025	25	7	6.6	1.2	1.2	11.9±0.6	355	0.734	127
	01C035	35	7	7.9	1.2	1.2	13.0±0.6	450	0.529	157
	01C050	50	19	9.1	1.4	1.3	15.1±0.6	610	0.391	196
	01C070	70	19	11.0	1.4	1.4	17.0±0.7	830	0.270	242
	01C095	95	19	12.9	1.6	1.5	19.4±0.8	1,105	0.195	293
	01C120	120	37	14.5	1.6	1.5	21.1±0.8	1,375	0.154	339
	01C150	150	37	16.2	1.8	1.6	23.3±0.9	1,685	0.126	389
	01C185	185	37	18.0	2.0	1.7	25.5±1.0	2,040	0.1000	444
01C240	240	61	20.6	2.2	1.8	29.0±1.2	2,700	0.0762	522	
01C300	300	61	23.1	2.4	1.9	31.7±1.3	3,265	0.0607	601	
2	02C001	1.0	7	1.4	1.0	1.1	10.6±0.6	130	18.2	15
	02C015	1.5	7	1.7	1.0	1.2	11.4±0.6	155	12.2	20
	02C025	2.5	7	2.2	1.0	1.2	12.2±0.6	185	7.56	26
	02C004	4	7	2.7	1.0	1.2	13.2±0.6	230	4.70	34
	02C006	6	7	3.3	1.0	1.3	14.6±0.6	295	3.11	44
	02C010	10	7	4.2	1.0	1.4	16.6±0.7	415	1.84	61
	02C016	16	7	5.3	1.0	1.4	18.6±0.7	565	1.16	82
	02C025	25	7	6.6	1.2	1.6	22.4±0.9	845	0.734	108
	02C035	35	7	7.9	1.2	1.7	24.8±1.0	1,080	0.529	133
	02C050	50	19	9.1	1.4	1.8	28.8±1.2	1,460	0.391	167
	02C070	70	19	11.0	1.4	1.9	32.4±1.3	1,960	0.270	206
	02C095	95	19	12.9	1.6	2.1	37.2±1.5	2,610	0.195	249
	02C120	120	37	14.5	1.6	2.3	41.0±1.6	3,270	0.154	288
	02C150	150	37	16.2	1.8	2.4	45.2±1.8	4,000	0.126	331
	02C185	185	37	18.0	2.0	2.6	49.6±2.0	4,840	0.1000	377
02C240	240	61	20.6	2.2	2.8	56.6±2.3	6,405	0.0762	444	
02C300	300	61	23.1	2.4	3.0	62.0±2.5	7,745	0.0607	511	

Example) 0.6/1kV BU 1C x 1.5mm² Part No. QXCD01C015

Q NEK606	C BU	X Fire resistant	D 0.6/1kV	01C No. of Core	015 Size (mm ²)
--------------------	----------------	----------------------------	---------------------	---------------------------	---------------------------------------

High Voltage Flame Retardant Cable

High Voltage Flame & Fire Resistant Cable

Low Voltage Flame Retardant Cable

Low Voltage Flame & Fire Resistant Cable

Technical information

0.6/1kV Unarmored Flame & Fire resistant, Halogen free Cable (Code : 0.6/1kV BU[P110])

No. of core	Part no.	Conductor			Thickness of insulation	Thickness of outer sheath	Nominal overall dia.	Cable weight approx.	Conductor resistance (20°C)	Current rating at 45°C
		Nominal sectional area	Min. No. of wires	Max. overall dia.						
EA	QCXD	mm ²	EA	mm	mm	mm	kg/km	Ω /km	Amp.	
3	03C001	1.0	7	1.4	1.0	1.2	11.4±0.6	160	18.2	12
	03C015	1.5	7	1.7	1.0	1.2	12.1±0.6	190	12.2	16
	03C025	2.5	7	2.2	1.0	1.2	12.9±0.6	230	7.56	21
	03C004	4	7	2.7	1.0	1.3	14.2±0.6	295	4.70	28
	03C006	6	7	3.3	1.0	1.3	15.5±0.6	385	3.11	36
	03C010	10	7	4.2	1.0	1.4	17.7±0.7	540	1.84	50
	03C016	16	7	5.3	1.0	1.5	20.0±0.8	755	1.16	67
	03C025	25	7	6.6	1.2	1.6	23.9±1.0	1130	0.734	89
	03C035	35	7	7.9	1.2	1.7	26.4±1.1	1450	0.529	110
	03C050	50	19	9.1	1.4	1.9	30.9±1.2	1985	0.391	137
	03C070	70	19	11.0	1.4	2.0	34.8±1.4	2685	0.270	169
	03C095	95	19	12.9	1.6	2.2	39.9±1.6	3585	0.195	205
	03C120	120	37	14.5	1.6	2.4	44.0±1.8	4500	0.154	237
	03C150	150	37	16.2	1.8	2.5	48.5±1.9	5520	0.126	272
	03C185	185	37	18.0	2.0	2.7	53.2±2.1	6690	0.1000	311
	03C240	240	61	20.6	2.2	3.0	60.9±2.4	8895	0.0762	365
03C300	300	61	23.1	2.4	3.2	66.7±2.7	10770	0.0607	421	
4	04C001	1.0	7	1.4	1.0	1.2	12.5±0.6	195	18.2	12
	04C015	1.5	7	1.7	1.0	1.2	13.2±0.6	230	12.2	16
	04C025	2.5	7	2.2	1.0	1.3	14.4±0.6	290	7.56	21
	04C004	4	7	2.7	1.0	1.3	15.6±0.6	375	4.70	28
	04C006	6	7	3.3	1.0	1.4	17.2±0.7	485	3.11	36
	04C010	10	7	4.2	1.0	1.5	19.6±0.8	690	1.84	50
	04C016	16	7	5.3	1.0	1.6	22.2±0.9	975	1.16	67
	04C025	25	7	6.6	1.2	1.7	26.5±1.1	1460	0.734	89
	04C035	35	7	7.9	1.2	1.8	29.4±1.2	1880	0.529	110
	04C050	50	19	9.1	1.4	2.0	34.4±1.4	2570	0.391	137
	04C070	70	19	11.0	1.4	2.2	38.9±1.6	3505	0.270	169
	04C095	95	19	12.9	1.6	2.4	44.6±1.8	4680	0.195	205
	04C120	120	37	14.5	1.6	2.6	49.1±2.0	5875	0.154	237
	04C150	150	37	16.2	1.8	2.7	54.1±2.2	7205	0.126	272
	04C185	185	37	18.0	2.0	2.9	59.3±2.4	8735	0.1000	311
	04C240	240	61	20.6	2.2	3.3	68.1±2.7	11650	0.0762	365
04C300	300	61	23.1	2.4	3.5	74.6±3.0	14100	0.0607	421	

Example) 0.6/1kV BU 3C x 1.5mm² Part No. QCXD03C015

Q NEK606	C BU	X Fire resistant	D 0.6/1kV	03C No. of Core	015 Size (mm ²)
--------------------	----------------	----------------------------	---------------------	---------------------------	---------------------------------------

0.6/1kV Unarmored Flame & Fire resistant, Halogen free Cable (Code : 0.6/1kV BU[P110])

No. of core	Part no.	Conductor			Thickness of insulation	Thickness of outer sheath	Nominal overall dia.	Cable weight approx.	Conductor resistance (20°C)	Current rating at 45°C
		Nominal sectional area	Min. No. of wires	Max. overall dia.						
EA	QCXD	mm ²	EA	mm	mm	mm	kg/km	Ω/km	Amp.	
5	05C001	1.0	7	1.4	1.0	1.2	12.6±0.5	205	18.2	10
6	06C001	1.0	7	1.4	1.0	1.3	13.9±0.6	245	18.2	9
7	07C001	1.0	7	1.4	1.0	1.3	13.9±0.6	255	18.2	9
8	08C001	1.0	7	1.4	1.0	1.3	15.0±0.6	295	18.2	9
9	09C001	1.0	7	1.4	1.0	1.3	16.2±0.6	335	18.2	8
10	10C001	1.0	7	1.4	1.0	1.4	17.8±0.7	365	18.2	8
12	12C001	1.0	7	1.4	1.0	1.4	18.4±0.7	410	18.2	7
14	14C001	1.0	7	1.4	1.0	1.5	19.5±0.8	470	18.2	7
16	16C001	1.0	7	1.4	1.0	1.5	20.6±0.8	530	18.2	7
19	19C001	1.0	7	1.4	1.0	1.5	21.7±0.9	585	18.2	6
20	20C001	1.0	7	1.4	1.0	1.6	22.6±0.9	645	18.2	6
23	23C001	1.0	7	1.4	1.0	1.6	24.2±1.0	725	18.2	6
24	24C001	1.0	7	1.4	1.0	1.7	25.8±1.0	765	18.2	6
27	27C001	1.0	7	1.4	1.0	1.7	26.4±1.1	835	18.2	6
30	30C001	1.0	7	1.4	1.0	1.8	27.5±1.1	930	18.2	5
33	33C001	1.0	7	1.4	1.0	1.8	28.6±1.1	1010	18.2	5
37	37C001	1.0	7	1.4	1.0	1.8	29.7±1.2	1090	18.2	5
44	44C001	1.0	7	1.4	1.0	2.0	33.8±1.4	1325	18.2	5
5	05C015	1.5	7	1.7	1.0	1.2	13.4±0.5	245	12.2	13
6	06C015	1.5	7	1.7	1.0	1.3	14.8±0.6	290	12.2	12
7	07C015	1.5	7	1.7	1.0	1.3	14.8±0.6	315	12.2	12
8	08C015	1.5	7	1.7	1.0	1.3	16.0±0.6	360	12.2	11
9	09C015	1.5	7	1.7	1.0	1.4	17.5±0.7	415	12.2	11
10	10C015	1.5	7	1.7	1.0	1.4	19.0±0.8	440	12.2	10
12	12C015	1.5	7	1.7	1.0	1.5	19.8±0.8	505	12.2	10
14	14C015	1.5	7	1.7	1.0	1.5	20.9±0.8	575	12.2	9
16	16C015	1.5	7	1.7	1.0	1.6	22.2±0.9	655	12.2	9
19	19C015	1.5	7	1.7	1.0	1.6	23.4±0.9	730	12.2	8
20	20C015	1.5	7	1.7	1.0	1.6	24.1±1.0	790	12.2	8
23	23C015	1.5	7	1.7	1.0	1.7	26.1±1.0	900	12.2	8
24	24C015	1.5	7	1.7	1.0	1.8	27.8±1.1	955	12.2	7
27	27C015	1.5	7	1.7	1.0	1.8	28.4±1.1	1045	12.2	7
30	30C015	1.5	7	1.7	1.0	1.8	29.5±1.2	1140	12.2	7
33	33C015	1.5	7	1.7	1.0	1.9	30.8±1.2	1255	12.2	7
37	37C015	1.5	7	1.7	1.0	1.9	32.0±1.3	1365	12.2	6
44	44C015	1.5	7	1.7	1.0	2.1	36.4±1.5	1655	12.2	6

High Voltage Flame Retardant Cable

High Voltage Flame & Fire Resistant Cable

Low Voltage Flame Retardant Cable

Low Voltage Flame & Fire Resistant Cable

Technical information

Example) 0.6/1kV BU 5C x 1.5mm² Part No. QCXD05C015

Q NEK606	C BU	X Fire resistant	D 0.6/1kV	05C No. of Core	015 Size (mm ²)
--------------------	----------------	----------------------------	---------------------	---------------------------	---------------------------------------

0.6/1kV Unarmored Flame & Fire resistant Halogen free Cable (Code : 0.6/1kV BU[P110])

No. of core	Part no.	Conductor			Thickness of insulation	Thickness of outer sheath	Nominal overall dia.	Cable weight approx.	Conductor resistance (20°C)	Current rating at 45°C
		Nominal sectional area	Min. No. of wires	Max. overall dia.						
EA	QCXD	mm ²	EA	mm	mm	mm	kg/km	Ω /km	Amp.	
5	05C025	2.5	7	2.2	1.0	1.3	14.7±0.6	320	7.56	17
6	06C025	2.5	7	2.2	1.0	1.3	16.0±0.6	375	7.56	16
7	07C025	2.5	7	2.2	1.0	1.3	16.0±0.6	400	7.56	15
8	08C025	2.5	7	2.2	1.0	1.4	17.5±0.7	465	7.56	15
9	09C025	2.5	7	2.2	1.0	1.4	18.9±0.8	525	7.56	14
10	10C025	2.5	7	2.2	1.0	1.5	20.8±0.8	570	7.56	13
12	12C025	2.5	7	2.2	1.0	1.5	21.5±0.9	650	7.56	13
14	14C025	2.5	7	2.2	1.0	1.6	22.8±0.9	750	7.56	12
16	16C025	2.5	7	2.2	1.0	1.6	24.1±1.0	840	7.56	11
19	19C025	2.5	7	2.2	1.0	1.7	25.6±1.0	965	7.56	11
20	20C025	2.5	7	2.2	1.0	1.7	26.4±1.1	1040	7.56	11
23	23C025	2.5	7	2.2	1.0	1.8	28.5±1.1	1185	7.56	10
24	24C025	2.5	7	2.2	1.0	1.9	30.4±1.2	1245	7.56	10
27	27C025	2.5	7	2.2	1.0	1.9	31.1±1.2	1370	7.56	10
30	30C025	2.5	7	2.2	1.0	1.9	32.2±1.3	1500	7.56	9
33	33C025	2.5	7	2.2	1.0	2.0	33.7±1.3	1650	7.56	9
37	37C025	2.5	7	2.2	1.0	2.0	35.0±1.4	1795	7.56	9
44	44C025	2.5	7	2.2	1.0	2.2	39.8±1.6	2175	7.56	8

Example) 0.6/1kV BU 5C x 2.5mm² Part No. QCXD05C025

Q NEK606	C BU	X Fire resistant	D 0.6/1kV	05C No. of Core	025 Size (mm ²)
--------------------	----------------	----------------------------	---------------------	---------------------------	---------------------------------------

LV Power Cable | Armored Flame & Fire resistant, Halogen free Cables (0.6/1kV BFOU)



Application

- Power circuit below 1kV, Fire fighting circuits and safety systems.
- Fixed installation power, control & lighting in both explosion risk and safe areas, emergency and critical systems.
- Maximum operating conductor temperature 90°C

Construction Details

- 1 Conductor** : Circular tinned stranded copper as per IEC 60228 class 2 or class5
- 2 Insulation** : Mica tape and Halogen-free Ethylene propylene rubber (EPR) as per IEC 60092-360
- 3 Core assembly** : Cabled with non-hygroscopic fillers and the binder tape may be applicable
- 4 Bedding** : Halogen-free compound (Inner covering)
- 5 Armor** : Copper wires braid (screen) as per IEC 60092-353
— BFCU(option) : Galvanized steel wire braid as per IEC 60092-353
- 6 Outer Sheath** : Halogen-free thermosetting compound as per IEC 60092-360, SHF2 or SHF2 Oil & Mud

Standards Applied

- **Design guideline** : IEC 60092-353, NEK606
- **Material properties** : IEC 60092-360, Insulation (EPR)
IEC 60092-360, Sheath (SHF2)
- **Flame retardant** : IEC 60332-3, Cat. 'A'
- **Fire resistant** : IEC 60331-1/2, at 830°C for 120 min.
(option) waterspray for 15min
- **Assessment of halogen** : IEC 60754-1/2 & 60684-2
- **Low smoke properties** : IEC 61034-1/2
- **Sunlight resistance** : UL 1581
- **Cold properties(option)** : CSA C22.2 No. 03. Cold bending(-50°C), Cold impact(-50°C)
- **Oil/Mud resistance(option)** : NEK TS 606 5th ed (Category a, b, c, d)

Identification of color

- **Insulation** : -1C : Grey (off-white)
-2C : Grey, Black
-3C : Grey, Black, Red
-4C : Grey, Black, Red, Blue
-5Core and above : By numbering on White colored insulation
-Earth core : Green/Yellow stripe
- **Outer sheath** : Black

Note) The any other identification of color may be applicable when purchaser required

Note1)

Cross section of Armor (for 2, 3, 4 core cable)

Cross section Q of associated current carrying conductor	Min. cross section of braiding wire
$Q \leq 16\text{mm}^2$	Q
$Q > 16\text{mm}^2$	1/2 of the current-carrying conductor, but not less than 16mm^2

Approvals

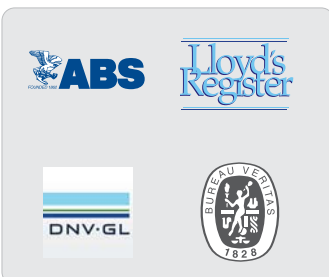

-35 to 90°C



Flame & Fire resistance
IEC 60332-3 A &
IEC 60331



Cold impact
CSA C22.2 No.38, -65°C
Special requirement



Halogen free



Weather
Resistance to severe
weather conditions



Chemical attacks
Resistance to
chemicals



Smoke-Corrosivity-Toxicity
Smoke density, gases corrosivity and toxicity



Resistance to Mud
NEK TS 606



OIL
Resistance to
Enhanced oil &
Hydraulic/gear oil

High Voltage Flame
Retardant Cable

High Voltage Flame
& Fire Resistant Cable

Low Voltage Flame
Retardant Cable

Low Voltage Flame
& Fire Resistant Cable

Technical information

0.6/1kV Armored Flame & Fire resistant, Halogen free Cable (CODE : 0.6/1kV BFOU[P105])

No. of core	Part no.	Conductor		Thickness of insulation	Thickness of inner covering	Nominal dia. over inner covering	Dia. of metal wire for braid	Thickness of outer sheath	Nominal overall dia.	Cable weight approx	Conductor resistance (20 °C)	Current rating at 45 °C
		Nominal sectional area	Max. overall dia.									
EA	QEXD	mm ²	mm	mm	mm	mm	mm	mm	mm	kg/km	Ω /km	Amp.
1	01C001	1.0/3	1.4	1.0	1.0	5.7	0.2	1.1	8.8±0.6	120	18.2	18
	01C015	1.5/3	1.7	1.0	1.0	6.0	0.2	1.1	9.1±0.6	135	12.2	23
	01C025	2.5/3	2.2	1.0	1.0	6.4	0.2	1.1	9.5±0.6	150	7.56	30
	01C004	4/3	2.7	1.0	1.0	6.9	0.2	1.1	10.0±0.6	175	4.70	40
	01C006	6/4	3.3	1.0	1.0	7.5	0.2	1.1	10.6±0.6	205	3.11	52
	01C010	10/4	4.2	1.0	1.0	8.4	0.2	1.2	11.7±0.6	260	1.84	72
	01C016	16/4	5.3	1.0	1.0	9.4	0.2	1.2	12.7±0.6	340	1.16	96
	01C025	25/9	6.6	1.2	1.0	11.1	0.3	1.3	15.1±0.6	510	0.734	127
	01C035	35/10	7.9	1.2	1.0	12.2	0.3	1.3	16.2±0.6	620	0.529	157
	01C050	50/12	9.1	1.4	1.0	14.1	0.3	1.4	18.3±0.7	800	0.391	196
	01C070	70/12	11.0	1.4	1.0	15.8	0.3	1.5	20.2±0.8	1045	0.270	242
	01C095	95/13	12.9	1.6	1.0	18.0	0.3	1.6	22.6±0.9	1345	0.195	293
	01C120	120/13	14.5	1.6	1.0	19.7	0.3	1.6	24.3±1.0	1635	0.154	339
	01C150	150/16	16.2	1.8	1.0	21.7	0.3	1.7	26.5±1.1	1975	0.126	389
	01C185	185/18	18.0	2.0	1.0	23.7	0.3	1.8	28.7±1.1	2350	0.1000	444
01C240	240/20	20.6	2.2	1.2	27.3	0.3	1.9	32.5±1.3	3075	0.0762	522	
01C300	300/26	23.1	2.4	1.2	29.8	0.3	2.0	35.2±1.4	3675	0.0607	601	
2	02C001	1.0/3	1.4	1.0	1.0	10.0	0.2	1.2	13.3±0.6	235	18.2	15
	02C015	1.5/4	1.7	1.0	1.0	10.6	0.3	1.3	14.6±0.6	300	12.2	20
	02C025	2.5/6	2.2	1.0	1.0	11.4	0.3	1.3	15.4±0.6	350	7.56	26
	02C004	4/6	2.7	1.0	1.0	12.4	0.3	1.4	16.6±0.7	410	4.70	34
	02C006	6/6	3.3	1.0	1.0	13.6	0.3	1.4	17.8±0.7	485	3.11	44
	02C010	10/10	4.2	1.0	1.0	15.4	0.3	1.5	19.8±0.8	620	1.84	61
	02C016	16/16	5.3	1.0	1.0	17.4	0.3	1.6	22.0±0.9	805	1.16	82
	02C025	25/16	6.6	1.2	1.0	20.8	0.3	1.7	25.6±1.0	1125	0.734	108
	02C035	35/25	7.9	1.2	1.0	23.0	0.3	1.8	28.0±1.1	1385	0.529	133
	02C050	50/25	9.1	1.4	1.2	27.1	0.3	1.9	32.3±1.3	1835	0.391	167
	02C070	70/35	11.0	1.4	1.2	30.5	0.4	2.1	36.5±1.5	2470	0.270	206
	02C095	95/50	12.9	1.6	1.2	34.9	0.4	2.3	41.3±1.7	3195	0.195	249
	02C120	120	14.5	1.6	1.4	38.6	0.4	2.4	45.2±1.8	3920	0.154	288
	02C150	150	16.2	1.8	1.4	42.6	0.4	2.6	49.6±2.0	4735	0.126	331
	02C185	185	18.0	2.0	1.4	46.6	0.4	2.7	53.8±2.2	5625	0.1000	377
	02C240	240	20.6	2.2	1.6	53.6	0.4	3.0	61.4±2.5	7380	0.0762	444
	02C120*	120/60*	14.5	1.6	1.4	38.6	*0.4 ^{1/2}	2.5	47.2±1.9	4375	0.154	288
	02C150*	150/75*	16.2	1.8	1.4	42.6	*0.4 ^{1/2}	2.6	51.4±2.1	5215	0.126	331
	02C185*	185/95*	18.0	2.0	1.4	46.6	*0.45 ^{1/2}	2.8	56.3±2.3	6315	0.1000	377
02C240*	240/120*	20.6	2.2	1.6	53.6	*0.5 ^{1/2}	3.1	64.3±2.6	8305	0.0762	444	

Example) 0.6/1kV BFOU 1C x 1.5mm² Part No. QEXD01C015

Note) "*" double braided(option)

Q NEK606	E BFOU	X Fire resistant	D 0.6/1kV	01C No. of Core	015 Size (mm ²)
--------------------	------------------	----------------------------	---------------------	---------------------------	---------------------------------------

0.6/1kV Armored Flame & Fire resistant, Halogen free Cable (CODE : 0.6/1kV BFOU[P105])

No. of core	Part no.	Conductor		Thickness of insulation	Thickness of inner covering	Nominal dia. over inner covering	Dia. of metal wire for braid	Thickness of outer sheath	Nominal overall dia.	Cable weight approx	Conductor resistance (20°C)	Current rating at 45°C	
		Nominal sectional area	Max. overall dia.										
EA	QEXD	mm ²	mm	mm	mm	mm	mm	mm	mm	kg/km	Ω /km	Amp.	
2+E	03E025	25	6.6	1.2	1.0	21.9	0.3	1.7	26.7±1.1	1325	0.734	108	
		16E	5.3	1.0							1.16		
	03E035	35	7.9	1.2	1.0	24.4	0.3	1.8	29.4±1.2	1695	0.529	133	
		25E	6.6	1.2							0.734		
	03E050	50	9.1	1.4	1.2	28.5	0.3	2.0	33.9±1.4	2165	0.391	167	
		25E	6.6	1.2							0.734		
	03E070	70	11.0	1.4	1.2	32.0	0.4	2.2	38.2±1.5	2900	0.270	206	
		35E	7.9	1.2							0.529		
	03E095	95	12.9	1.6	1.2	36.7	0.4	2.3	43.1±1.7	3750	0.195	249	
		50E	9.1	1.4							0.391		
	03E120	120	14.5	1.8	1.4	40.6	0.4	2.5	47.4±1.9	4705	0.154	288	
		70E	11.0	1.6							0.270		
	03E150	150	16.2	2.0	1.4	45.0	0.4	2.7	52.2±2.1	5790	0.126	331	
		95E	12.9	1.6							0.195		
	03E185	185	18.0	2.2	1.6	49.3	0.4	2.8	56.7±2.3	6730	0.100	377	
		95E	12.9	1.6							0.195		
	3	03C001	1.0/3	1.4	1.0	1.0	10.6	0.3	1.3	14.6±0.6	315	18.2	12
		03C015	1.5/4	1.7	1.0	1.0	11.3	0.3	1.3	15.3±0.6	350	12.2	16
03C025		2.5/6	2.2	1.0	1.0	12.1	0.3	1.3	16.1±0.6	400	7.56	21	
03C004		4/6	2.7	1.0	1.0	13.2	0.3	1.4	17.4±0.7	480	4.70	28	
03C006		6/6	3.3	1.0	1.0	14.5	0.3	1.4	18.7±0.7	580	3.11	36	
03C010		10/10	4.2	1.0	1.0	16.5	0.3	1.5	20.9±0.8	760	1.84	50	
03C016		16/16	5.3	1.0	1.0	18.6	0.3	1.6	23.2±0.9	1010	1.16	67	
03C025		25/16	6.6	1.2	1.0	22.3	0.3	1.7	27.1±1.1	1425	0.734	89	
03C035		35/25	7.9	1.2	1.0	24.6	0.3	1.8	29.6±1.2	1775	0.529	110	
03C050		50/25	9.1	1.4	1.2	29.0	0.3	2.0	34.4±1.4	2385	0.391	137	
03C070		70/35	11.0	1.4	1.2	32.7	0.4	2.2	38.9±1.6	3235	0.270	169	
03C095		95/50	12.9	1.6	1.4	37.7	0.4	2.4	44.3±1.8	4240	0.195	205	
03C120		120	14.5	1.6	1.4	41.4	0.4	2.5	48.2±1.9	5200	0.154	237	
03C150		150	16.2	1.8	1.4	45.7	0.4	2.7	52.9±2.1	6310	0.126	272	
03C185		185	18.0	2.0	1.6	50.4	0.4	2.9	58.0±2.3	7605	0.1000	311	
03C240		240	20.6	2.2	1.6	57.5	0.4	3.2	65.7±2.6	9940	0.0762	365	
03C300		300	23.1	2.4	1.8	63.2	0.4	3.4	71.8±2.9	11960	0.0607	421	
03C120*		120/60*	14.5	1.6	1.4	41.4	*0.4 ^{1/2}	2.6	50.2±2.0	5685	0.154	237	
03C150*		150/75*	16.2	1.8	1.4	45.7	*0.4 ^{1/2}	2.8	54.9±2.2	6845	0.126	272	
03C185*		185/95*	18.0	2.0	1.6	50.4	*0.45 ^{1/2}	3.0	60.5±2.4	8350	0.1000	311	
03C240*	240/120*	20.6	2.2	1.6	57.5	*0.5 ^{1/2}	3.3	68.6±2.7	10930	0.0762	365		

High Voltage Flame Retardant Cable

High Voltage Flame & Fire Resistant Cable

Low Voltage Flame Retardant Cable

Low Voltage Flame & Fire Resistant Cable

Technical information

Example) 0.6/1kV BFOU 3C x 1.5mm² Part No. **QEXD03C015**

Note) "*" double braided(option)

Q	E	X	D	03C	015
NEK606	BFOU	Fire resistant	0.6/1kV	No. of Core	Size (mm ²)

0.6/1kV Armored Flame & Fire resistant, Halogen free Cable(Code : 0.6/1kV BFOU[P105])

No. of core	Part no.	Conductor		Thickness of insulation	Thickness of inner covering	Nominal dia. over inner covering	Dia. of metal wire for braid	Thickness of outer sheath	Nominal overall dia.	Cable weight approx	Conductor resistance (20°C)	Current rating at 45°C	
		Nominal sectional area	Max. overall dia.										
EA	QEXD	mm ²	mm	mm	mm	mm	mm	mm	mm	kg/km	Ω/km	Amp.	
3+E	04E025	25	6.6	1.2	1.0	23.9	0.3	1.8	28.9±1.2	1650	0.734	89	
		16E	5.3	1.0							1.16		
	04E035	35	7.9	1.2	1.2	27.1	0.4	1.9	32.3±1.3	2140	0.529	110	
		25E	6.6	1.2							0.734		
	04E050	50	9.1	1.4	1.2	30.8	0.4	2.1	36.8±1.5	2800	0.391	137	
		25E	6.6	1.2							0.734		
	04E070	70	11.0	1.4	1.2	34.6	0.4	2.3	41.0±1.6	3675	0.270	169	
		35E	7.9	1.2							0.529		
	04E095	95	12.9	1.6	1.4	40.0	0.4	2.5	46.8±1.9	4835	0.195	205	
		50E	9.1	1.4							0.391		
	04E120	120	14.5	1.6	1.4	44.1	0.4	2.6	51.1±2.0	6010	0.154	237	
		70E	11.0	1.4							0.270		
	04E150	150	16.2	1.8	1.6	48.4	0.4	2.8	55.8±2.2	7165	0.126	272	
		95E	12.9	1.4							0.195		
	04E185	185	18.0	2.0	1.6	53.3	0.4	3.0	61.1±2.4	8685	0.100	311	
		95E	12.9	1.6							0.195		
	4	04C001	1.0/3	1.4	1.0	1.0	11.7	0.3	1.3	15.7±0.6	360	18.2	12
		04C015	1.5/3	1.7	1.0	1.0	12.4	0.3	1.4	16.6±0.7	410	12.2	16
04C025		2.5/6	2.2	1.0	1.0	13.4	0.3	1.4	17.6±0.7	480	7.56	21	
04C004		4/6	2.7	1.0	1.0	14.6	0.3	1.4	18.8±0.8	570	4.70	28	
04C006		6/6	3.3	1.0	1.0	16.0	0.3	1.5	20.4±0.8	700	3.11	36	
04C010		10/10	4.2	1.0	1.0	18.2	0.3	1.6	22.8±0.9	935	1.84	50	
04C016		16/16	5.3	1.0	1.0	20.6	0.3	1.7	25.4±1.0	1250	1.16	67	
04C025		25/16	6.6	1.2	1.0	24.7	0.3	1.8	29.7±1.2	1785	0.734	89	
04C035		35/25	7.9	1.2	1.2	27.7	0.3	2.0	33.1±1.3	2275	0.529	110	
04C050		50/25	9.1	1.4	1.2	32.3	0.4	2.2	38.5±1.5	3115	0.391	137	
04C070		70/35	11.0	1.4	1.2	36.4	0.4	2.3	42.8±1.7	4095	0.270	169	
04C095		95/50	12.9	1.6	1.4	42.0	0.4	2.6	49.0±2.0	5405	0.195	205	
04C120		120	14.5	1.6	1.4	46.1	0.4	2.7	53.3±2.1	6650	0.154	237	
04C150		150	16.2	1.8	1.6	51.3	0.4	2.9	58.9±2.4	8140	0.126	272	
04C185		185	18.0	2.0	1.6	56.1	0.4	3.1	64.1±2.6	9755	0.1000	311	
04C240		240	20.6	2.2	1.8	64.4	0.4	3.4	73.0±2.9	12830	0.0762	365	
04C300		300	23.1	2.4	1.8	70.5	0.4	3.7	79.7±3.2	15430	0.0607	421	
04C120*		120/60*	14.5	1.6	1.4	46.1	*0.4 ^{1/2}	2.8	55.3±2.2	7190	0.154	237	
04C150*		150/75*	16.2	1.8	1.6	51.3	*0.4 ^{1/2}	3.0	60.9±2.4	8735	0.126	272	
04C185*		185/95*	18.0	2.0	1.6	56.1	*0.45 ^{1/2}	3.2	66.6±2.7	10575	0.1000	311	
04C240*	240/120*	20.6	2.2	1.8	64.4	*0.5 ^{1/2}	3.6	76.1±3.0	13965	0.0762	365		

Example] 0.6/1kV BFOU 4C x 1.5mm² Part No. QEXD01C015

Note] "*" double braided(option)

Q	E	X	D	04C	015
NEK606	BFOU	Fire resistant	0.6/1kV	No. of Core	Size (mm ²)

0.6/1kV Armored Flame & Fire resistant, Halogen free Cable(Code : 0.6/1kV BFOU[P105])

No. of core	Part no.	Conductor		Thickness of insulation	Thickness of inner covering	Nominal dia. over inner covering	Dia. of metal wire for braid	Thickness of outer sheath	Nominal overall dia.	Cable weight approx	Conductor resistance (20°C)	Current rating at 45°C
		Nominal sectional area	Max. overall dia.									
EA	QEXD	mm ²	mm	mm	mm	mm	mm	mm	mm	kg/km	Ω /km	Amp.
4+E	05E025	25	6.6	1.2	1.2	27.4	0.3	2.0	32.8±1.3	2065	0.734	89
		16E	5.3	1.0							1.16	
	05E035	35	7.9	1.2	1.2	30.6	0.4	2.1	36.6±1.5	2715	0.529	110
		25E	6.6	1.2							0.734	
	05E050	50	9.1	1.4	1.2	35.2	0.4	2.3	41.6±1.7	3485	0.391	137
		25E	6.6	1.2							0.734	
	05E070	70	11.0	1.4	1.4	40.0	0.4	2.5	46.8±1.9	4625	0.270	169
		35E	7.9	1.2							0.529	
	05E095	95	12.9	1.6	1.4	45.9	0.4	2.7	53.1±2.1	6055	0.195	205
		50E	9.1	1.4							0.391	
	05E120	120	14.5	1.6	1.6	50.9	0.4	2.9	58.5±2.3	7595	0.154	237
		70E	11.0	1.4							0.270	
	05E150	150	16.2	1.8	1.6	56.4	0.4	3.1	64.4±2.6	9315	0.126	272
		95E	12.9	1.6							0.195	
	05E185	185	18.0	2.0	1.6	61.2	0.4	3.3	69.6±2.8	10935	0.100	311
		95E	12.9	1.6							0.195	

Example) 0.6/1kV BFOU 5E x 25mm² Part No. QEXD05E025

Q	E	X	D	05E	025
NEK606	BFOU	Fire resistant	0.6/1kV	No. of Core	Size (mm ²)

High Voltage Flame Retardant Cable

High Voltage Flame & Fire Resistant Cable

Low Voltage Flame Retardant Cable

Low Voltage Flame & Fire Resistant Cable

Technical information

0.6/1kV Armored Flame & Fire resistant, Halogen free Cable(Code : 0.6/1kV BFOU[P105])

No. of core	Part no.	Conductor		Thickness of insulation	Thickness of inner covering	Nominal dia. over inner covering	Dia. of metal wire for braid	Thickness of outer sheath	Nominal overall dia.	Cable weight approx	Conductor resistance (20°C)	Current rating at 45°C
		Nominal sectional area	Max. overall dia.									
EA	QEXD	mm ²	mm	mm	mm	mm	mm	mm	mm	kg/km	Ω/km	Amp.
5	05C001	1.0	1.4	1.0	1.0	11.8	0.3	1.3	15.8±0.6	370	18.2	10
6	06C001	1.0	1.4	1.0	1.0	12.9	0.3	1.4	17.1±0.6	425	18.2	9
7	07C001	1.0	1.4	1.0	1.0	12.9	0.3	1.4	17.1±0.6	440	18.2	9
8	08C001	1.0	1.4	1.0	1.0	14.0	0.3	1.4	18.2±0.6	490	18.2	9
9	09C001	1.0	1.4	1.0	1.0	15.2	0.3	1.5	19.6±0.6	550	18.2	8
10	10C001	1.0	1.4	1.0	1.0	16.6	0.3	1.5	21.0±0.6	585	18.2	8
12	12C001	1.0	1.4	1.0	1.0	17.2	0.3	1.5	21.6±0.6	640	18.2	7
14	14C001	1.0	1.4	1.0	1.0	18.1	0.3	1.6	22.7±0.6	715	18.2	7
16	16C001	1.0	1.4	1.0	1.0	19.2	0.3	1.6	23.8±0.6	785	18.2	7
19	19C001	1.0	1.4	1.0	1.0	20.3	0.3	1.7	25.1±1.0	865	18.2	6
20	20C001	1.0	1.4	1.0	1.0	21.0	0.3	1.7	25.8±1.0	930	18.2	6
23	23C001	1.0	1.4	1.0	1.0	22.6	0.3	1.8	27.6±1.1	1040	18.2	6
24	24C001	1.0	1.4	1.0	1.0	24.0	0.3	1.8	29.0±1.2	1085	18.2	6
27	27C001	1.0	1.4	1.0	1.0	24.6	0.3	1.8	29.6±1.2	1160	18.2	6
30	30C001	1.0	1.4	1.0	1.0	25.5	0.3	1.9	30.7±1.2	1265	18.2	5
33	33C001	1.0	1.4	1.0	1.0	26.6	0.3	1.9	31.8±1.3	1355	18.2	5
37	37C001	1.0	1.4	1.0	1.2	28.0	0.3	2.0	33.4±1.3	1495	18.2	5
44	44C001	1.0	1.4	1.0	1.2	31.7	0.4	2.1	37.7±1.5	1840	18.2	5
5	05C015	1.5	1.7	1.0	1.0	12.6	0.3	1.4	16.8±0.6	430	12.2	13
6	06C015	1.5	1.7	1.0	1.0	13.8	0.3	1.4	18.0±0.6	485	12.2	12
7	07C015	1.5	1.7	1.0	1.0	13.8	0.3	1.4	18.0±0.6	505	12.2	12
8	08C015	1.5	1.7	1.0	1.0	15.0	0.3	1.5	19.4±0.6	570	12.2	11
9	09C015	1.5	1.7	1.0	1.0	16.3	0.3	1.5	20.7±0.6	635	12.2	11
10	10C015	1.5	1.7	1.0	1.0	17.8	0.3	1.6	22.4±0.6	685	12.2	10
12	12C015	1.5	1.7	1.0	1.0	18.4	0.3	1.6	23.0±0.6	755	12.2	10
14	14C015	1.5	1.7	1.0	1.0	19.5	0.3	1.6	24.1±0.6	835	12.2	9
16	16C015	1.5	1.7	1.0	1.0	20.6	0.3	1.7	25.4±1.0	935	12.2	9
19	19C015	1.5	1.7	1.0	1.0	21.8	0.3	1.7	26.6±1.1	1025	12.2	8
20	20C015	1.5	1.7	1.0	1.0	22.5	0.3	1.8	27.5±1.1	1105	12.2	8
23	23C015	1.5	1.7	1.0	1.0	24.3	0.3	1.8	29.3±1.2	1225	12.2	8
24	24C015	1.5	1.7	1.0	1.0	25.8	0.3	1.9	31.0±1.2	1295	12.2	7
27	27C015	1.5	1.7	1.0	1.0	26.4	0.3	1.9	31.6±1.3	1390	12.2	7
30	30C015	1.5	1.7	1.0	1.2	27.8	0.3	2.0	33.2±1.3	1540	12.2	7
33	33C015	1.5	1.7	1.0	1.2	28.9	0.3	2.0	34.3±1.4	1655	12.2	7
37	37C015	1.5	1.7	1.0	1.2	30.1	0.4	2.1	36.1±1.4	1870	12.2	6
44	44C015	1.5	1.7	1.0	1.2	34.1	0.4	2.2	40.3±1.6	2205	12.2	6

Example) 0.6/1kV BFOU 5C x 1.5mm² Part No. QEXD05C015

Q NEK606	E BFOU	X Fire resistant	D 0.6/1kV	05C No. of Core	015 Size (mm ²)
--------------------	------------------	----------------------------	---------------------	---------------------------	---------------------------------------

0.6/1kV Armored Flame & Fire resistant, Halogen free cable(Code : 0.6/1kV BFOU[P105])

No. of core	Part no.	Conductor		Thickness of insulation	Thickness of inner covering	Nominal dia. over inner covering	Dia. of metal wire for braid	Thickness of outer sheath	Nominal overall dia.	Cable weight approx	Conductor resistance (20°C)	Current rating at 45°C
		Nominal sectional area	Max. overall dia.									
EA	QEXD	mm ²	mm	mm	mm	mm	mm	mm	mm	kg/km	Ω /km	Amp.
5	05C025	2.5	2.2	1.0	1.0	13.7	0.3	1.4	17.9±0.6	505	7.56	17
6	06C025	2.5	2.2	1.0	1.0	15.0	0.3	1.5	19.4±0.6	585	7.56	16
7	07C025	2.5	2.2	1.0	1.0	15.0	0.3	1.5	19.4±0.6	610	7.56	15
8	08C025	2.5	2.2	1.0	1.0	16.3	0.3	1.5	20.7±0.6	685	7.56	15
9	09C025	2.5	2.2	1.0	1.0	17.7	0.3	1.6	22.3±1.6	770	7.56	14
10	10C025	2.5	2.2	1.0	1.0	19.4	0.3	1.6	24.0±1.6	825	7.56	13
12	12C025	2.5	2.2	1.0	1.0	20.1	0.3	1.7	24.9±1.6	930	7.56	13
14	14C025	2.5	2.2	1.0	1.0	21.2	0.3	1.7	26.0±1.0	1035	7.56	12
16	16C025	2.5	2.2	1.0	1.0	22.5	0.3	1.8	27.5±1.1	1155	7.56	11
19	19C025	2.5	2.2	1.0	1.0	23.8	0.3	1.8	28.8±1.2	1280	7.56	11
20	20C025	2.5	2.2	1.0	1.0	24.6	0.3	1.8	29.6±1.2	1365	7.56	11
23	23C025	2.5	2.2	1.0	1.2	26.5	0.3	1.9	31.7±1.3	1530	7.56	10
24	24C025	2.5	2.2	1.0	1.2	28.5	0.3	2.0	33.9±1.4	1640	7.56	10
27	27C025	2.5	2.2	1.0	1.2	29.2	0.3	2.0	34.6±1.4	1770	7.56	10
30	30C025	2.5	2.2	1.0	1.2	30.3	0.4	2.1	36.3±1.5	2005	7.56	9
33	33C025	2.5	2.2	1.0	1.2	31.6	0.4	2.1	37.6±1.5	2160	7.56	9
37	37C025	2.5	2.2	1.0	1.2	32.9	0.4	2.2	39.1±1.6	2350	7.56	9
44	44C025	2.5	2.2	1.0	1.4	37.6	0.4	2.4	44.2±1.8	2825	7.56	8

Example| 0.6/1kV BFOU 5C x 2.5mm² Part No. QEXD05C025

Q NEK606	E BFOU	X Fire resistant	D 0.6/1kV	05C No. of Core	025 Size (mm ²)
--------------------	------------------	----------------------------	---------------------	---------------------------	---------------------------------------

High Voltage Flame Retardant Cable

High Voltage Flame & Fire Resistant Cable

Low Voltage Flame Retardant Cable

Low Voltage Flame & Fire Resistant Cable

Technical information

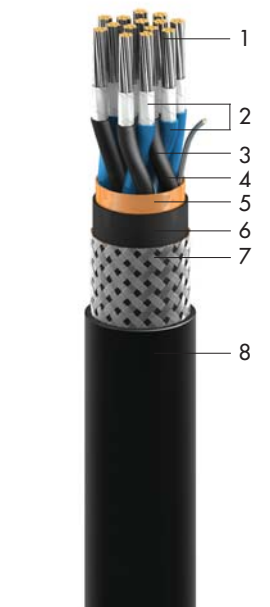

Application

- Instrument circuit up to 250V, instrument safe systems.
- Fixed installation for instrument, communication, control and alarm systems in both explosion risk and safe areas, emergency and critical systems.
- Maximum operating conductor temperature 90°C

Construction Details

- 1 Conductor** : Circular tinned stranded copper wires as per IEC 60228 class 2 or class5 & IEC 60092-376
- 2 Insulation** : Mica tape and Halogen-free Ethylene propylene rubber (EPR) as per IEC 60092-360
- 3 Pair/triple twisting** : Two/three insulated cores twisted together with suitable lay length
- 4 Core assembly** : Pairs/triples are laid up with non-hygroscopic fillers and the binder tape may be applicable
- 5 Collective screening** : Wrapped by copper or aluminium backed polyester tape with tinned copper drain wire
- 6 Bedding** : Halogen-free compound (Inner covering)
- 7 Armor** : Copper wires braid(screen) as per IEC 60092-376
– BFCU(option) : Galvanized steel wire braid as per IEC 60092-376
- 8 Outer Sheath** : Halogen-free thermosetting compound as per IEC 60092-360, SHF2 or SHF2 Oil & Mud

Standards Applied

- **Design guideline** : IEC 60092-376, NEK606
- **Material properties** : IEC 60092-360, Insulation (EPR)
IEC 60092-360, Sheath (SHF2)
- **Flame retardant** : IEC 60332-3, Cat. 'A'
- **Fire resistant** : IEC 60331-1/2, at 830°C for 120 min.
(option) waterspray for 15min
- **Assessment of halogen** : IEC 60754-1/2 & 60684-2
- **Low smoke properties** : IEC 61034-1/2
- **Sunlight resistance** : UL 1581
- **Cold properties(option)** : CSA C22.2 No. 03. Cold bending(-50°C), Cold impact(-50°C)
- **Oil/Mud resistance(option)** : NEK TS 606 5th ed (Category a, b, c, d)

Identification of color

- **Insulation** : -1Pair : Black, Light Blue
-1Triple : Black, Light Blue, Brown
-2Pair and above : Numbering on Black & Light Blue insulation core
-2Triple and above : Numbering on Black, Light Blue & Brown insulation core
- **Outer sheath** : Non I.S : Grey / I.S : Blue
Note) The any other identification of color may be applicable when purchaser required

Approvals

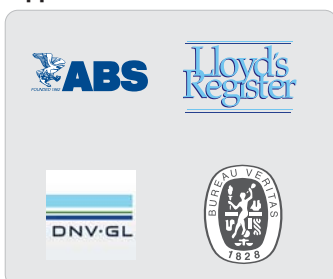

-35 to 90°C



Flame & Fire resistance
IEC 60332-3 A &
IEC 60331



Cold impact
CSA C22.2 No.38, -65°C
Special requirement



Halogen free



Weather
Resistance to severe
weather conditions



Chemical attacks
Resistance to
chemicals



Smoke-Corrosivity-Toxicity
Smoke density, gases corrosivity and toxicity



Resistance to Mud
NEK TS 606



Resistance to
Enhanced oil &
Hydraulic/gear oil

250V Armored Flame & Fire resistant, Halogen free collectively screened Instrument Cable (Code : 250V BFOU(C)[S104])

No. of pair	No. of core	Part no.	Conductor		Thickness of insulation	Thickness of inner covering	Nominal dia. over inner covering	Dia. of metal wire for braid	Thickness of outer sheath	Nominal overall dia.	Cable weight approx	Conductor resistance (20°C)
			Nominal sectional area	Max. overall dia.								
Pr	EA	QVXA	mm ²	mm	mm	mm	mm	mm	mm	kg/km	Ω /km	
1	2	01P075	0.75	1.2	0.6	1.0	7.6	0.2	1.1	10.7±0.6	170	26.3
2	4	02P075	0.75	1.2	0.6	1.0	11.5	0.3	1.3	15.5±0.6	345	26.3
3	6	03P075	0.75	1.2	0.6	1.0	12.1	0.3	1.3	16.1±0.6	390	26.3
4	8	04P075	0.75	1.2	0.6	1.0	13.1	0.3	1.4	17.3±0.6	455	26.3
5	10	05P075	0.75	1.2	0.6	1.0	14.4	0.3	1.4	18.6±0.6	520	26.3
6	12	06P075	0.75	1.2	0.6	1.0	15.8	0.3	1.5	20.2±0.6	600	26.3
7	14	07P075	0.75	1.2	0.6	1.0	15.8	0.3	1.5	20.2±0.6	625	26.3
8	16	08P075	0.75	1.2	0.6	1.0	17.4	0.3	1.6	22.0±0.6	705	26.3
9	18	09P075	0.75	1.2	0.6	1.0	18.7	0.3	1.6	23.3±0.6	790	26.3
10	20	10P075	0.75	1.2	0.6	1.0	19.7	0.3	1.6	24.3±0.6	830	26.3
12	24	12P075	0.75	1.2	0.6	1.0	20.2	0.3	1.7	25.0±1.0	920	26.3
14	28	14P075	0.75	1.2	0.6	1.0	21.4	0.3	1.7	26.2±1.0	1,030	26.3
15	30	15P075	0.75	1.2	0.6	1.0	23.0	0.3	1.8	28.0±1.1	1,115	26.3
16	32	16P075	0.75	1.2	0.6	1.0	23.5	0.3	1.8	28.5±1.1	1,170	26.3
18	36	18P075	0.75	1.2	0.6	1.0	24.8	0.3	1.8	29.8±1.2	1,280	26.3
19	38	19P075	0.75	1.2	0.6	1.0	25.1	0.3	1.9	30.3±1.2	1,295	26.3
20	40	20P075	0.75	1.2	0.6	1.0	26.2	0.3	1.9	31.4±1.3	1,400	26.3
21	42	21P075	0.75	1.2	0.6	1.2	27.4	0.3	2.0	32.8±1.3	1,470	26.3
23	46	23P075	0.75	1.2	0.6	1.2	27.8	0.3	2.0	33.2±1.3	1,565	26.3
24	48	24P075	0.75	1.2	0.6	1.2	29.3	0.3	2.0	34.7±1.4	1,645	26.3
27	54	27P075	0.75	1.2	0.6	1.2	30.0	0.3	2.1	35.6±1.4	1,770	26.3
30	60	30P075	0.75	1.2	0.6	1.2	31.2	0.4	2.1	37.2±1.5	2,005	26.3
32	64	32P075	0.75	1.2	0.6	1.2	32.1	0.4	2.2	38.3±1.5	2,110	26.3
37	74	37P075	0.75	1.2	0.6	1.2	33.7	0.4	2.2	39.9±1.6	2,330	26.3

Example) 250V BFOU(C) 1Pr x 0.75mm² Part No. QVXA01P0075

Q	V	X	A	01P	0075
NEK606	BFOU(C)	Fire resistant	150/250V	No. of Pair	Size (mm ²)

High Voltage Flame Retardant Cable

High Voltage Flame & Fire Resistant Cable

Low Voltage Flame Retardant Cable

Low Voltage Flame & Fire Resistant Cable

Technical information

250V Armored Flame & Fire resistant, Halogen free collectively screened Instrument Cable (Code : 250V BFOU(C)[S104])

No. of pair	No. of core	Part no.	Conductor		Thickness of insulation	Thickness of inner covering	Nominal dia. over inner covering	Dia. of metal wire for braid	Thickness of outer sheath	Nominal overall dia.	Cable weight approx	Conductor resistance (20°C)
			Nominal sectional area	Max. overall dia.								
Pr	EA	QVXA	mm ²	mm	mm	mm	mm	mm	mm	mm	kg/km	Ω /km
1	2	01P001	1.0	1.4	0.6	1.0	7.8	0.2	1.1	10.9±0.6	180	19.3
2	4	02P001	1.0	1.4	0.6	1.0	11.9	0.3	1.3	15.9±0.6	360	19.3
3	6	03P001	1.0	1.4	0.6	1.0	12.5	0.3	1.4	16.7±0.6	410	19.3
4	8	04P001	1.0	1.4	0.6	1.0	13.5	0.3	1.4	17.7±0.6	485	19.3
5	10	05P001	1.0	1.4	0.6	1.0	14.9	0.3	1.5	19.3±0.6	560	19.3
6	12	06P001	1.0	1.4	0.6	1.0	16.3	0.3	1.5	20.7±0.6	645	19.3
7	14	07P001	1.0	1.4	0.6	1.0	16.3	0.3	1.5	20.7±0.6	675	19.3
8	16	08P001	1.0	1.4	0.6	1.0	18.0	0.3	1.6	22.6±0.6	770	19.3
9	18	09P001	1.0	1.4	0.6	1.0	19.2	0.3	1.6	23.8±1.0	850	19.3
10	20	10P001	1.0	1.4	0.6	1.0	20.3	0.3	1.7	25.1±1.0	895	19.3
12	24	12P001	1.0	1.4	0.6	1.0	20.9	0.3	1.7	25.7±1.1	1,005	19.3
14	28	14P001	1.0	1.4	0.6	1.0	22.0	0.3	1.7	26.8±1.1	1,115	19.3
15	30	15P001	1.0	1.4	0.6	1.0	23.7	0.3	1.8	28.7±1.1	1,220	19.3
16	32	16P001	1.0	1.4	0.6	1.0	24.2	0.3	1.8	29.2±1.2	1,265	19.3
18	36	18P001	1.0	1.4	0.6	1.0	25.6	0.3	1.9	30.8±1.2	1,385	19.3
19	38	19P001	1.0	1.4	0.6	1.0	25.9	0.3	1.9	31.1±1.2	1,415	19.3
20	40	20P001	1.0	1.4	0.6	1.2	27.4	0.3	2.0	32.8±1.3	1,515	19.3
21	42	21P001	1.0	1.4	0.6	1.2	28.2	0.3	2.0	33.6±1.3	1,630	19.3
23	46	23P001	1.0	1.4	0.6	1.2	28.7	0.3	2.0	34.1±1.4	1,710	19.3
24	48	24P001	1.0	1.4	0.6	1.2	30.3	0.4	2.1	36.3±1.5	1,780	19.3
27	54	27P001	1.0	1.4	0.6	1.2	31.0	0.4	2.1	37.0±1.5	1,940	19.3
30	60	30P001	1.0	1.4	0.6	1.2	32.2	0.4	2.2	38.4±1.5	2,175	19.3
32	64	32P001	1.0	1.4	0.6	1.2	33.1	0.4	2.2	39.3±1.6	2,315	19.3
37	74	37P001	1.0	1.4	0.6	1.2	34.8	0.4	2.3	41.2±1.6	2,540	19.3
1	2	01P015	1.5	1.7	0.7	1.0	8.8	0.2	1.2	12.1±0.6	220	12.9
2	4	02P015	1.5	1.7	0.7	1.0	13.5	0.3	1.4	17.7±0.6	445	12.9
3	6	03P015	1.5	1.7	0.7	1.0	14.3	0.3	1.4	18.5±0.6	515	12.9
4	8	04P015	1.5	1.7	0.7	1.0	15.4	0.3	1.5	19.8±0.6	610	12.9
5	10	05P015	1.5	1.7	0.7	1.0	17.0	0.3	1.5	21.4±0.6	710	12.9
6	12	06P015	1.5	1.7	0.7	1.0	18.7	0.3	1.6	23.3±0.6	825	12.9
7	14	07P015	1.5	1.7	0.7	1.0	18.7	0.3	1.6	23.3±0.6	865	12.9
8	16	08P015	1.5	1.7	0.7	1.0	20.6	0.3	1.7	25.4±1.0	995	12.9
9	18	09P015	1.5	1.7	0.7	1.0	22.1	0.3	1.7	26.9±1.1	1,105	12.9
10	20	10P015	1.5	1.7	0.7	1.0	23.3	0.3	1.8	28.3±1.1	1,175	12.9
12	24	12P015	1.5	1.7	0.7	1.0	24.0	0.3	1.8	29.0±1.2	1,310	12.9
14	28	14P015	1.5	1.7	0.7	1.0	25.4	0.3	1.9	30.6±1.2	1,460	12.9
15	30	15P015	1.5	1.7	0.7	1.2	27.7	0.3	2.0	33.1±1.3	1,625	12.9
16	32	16P015	1.5	1.7	0.7	1.2	28.2	0.3	2.0	33.6±1.3	1,700	12.9
18	36	18P015	1.5	1.7	0.7	1.2	29.9	0.3	2.1	35.5±1.4	1,870	12.9
19	38	19P015	1.5	1.7	0.7	1.2	30.2	0.4	2.1	36.2±1.4	1,890	12.9
20	40	20P015	1.5	1.7	0.7	1.2	31.6	0.4	2.1	37.6±1.5	2,120	12.9
21	42	21P015	1.5	1.7	0.7	1.2	32.6	0.4	2.2	38.8±1.6	2,225	12.9
23	46	23P015	1.5	1.7	0.7	1.2	33.1	0.4	2.2	39.3±1.6	2,360	12.9
24	48	24P015	1.5	1.7	0.7	1.2	35.0	0.4	2.3	41.4±1.7	2,455	12.9
27	54	27P015	1.5	1.7	0.7	1.2	35.8	0.4	2.3	42.2±1.7	2,675	12.9
30	60	30P015	1.5	1.7	0.7	1.4	37.5	0.4	2.4	44.1±1.8	2,895	12.9
32	64	32P015	1.5	1.7	0.7	1.4	38.6	0.4	2.4	45.2±1.8	3,115	12.9
37	74	37P015	1.5	1.7	0.7	1.4	40.5	0.4	2.5	47.3±1.9	3,430	12.9

Example| 250V BFOU(C) 1Pr x 1.5mm² Part No. QVXA01P015

Q NEK606	V BFOU(C)	X Fire resistant	A 150/250V	01P No. of Pair	015 Size (mm ²)
--------------------	---------------------	----------------------------	----------------------	---------------------------	---------------------------------------

250V Armored Flame & Fire resistant, Halogen free collectively screened Instrument Cable (Code : 250V BFOU(C)[S104])

No. of pair	No. of core	Part no.	Conductor		Thickness of insulation	Thickness of inner covering	Nominal dia. over inner covering	Dia. of metal wire for braid	Thickness of outer sheath	Nominal overall dia.	Cable weight approx	Conductor resistance (20°C)
			Nominal sectional area	Max. overall dia.								
Pr	EA	QVXA	mm ²	mm	mm	mm	mm	mm	mm	mm	kg/km	Ω /km
1	2	01T025	2.5	2.2	0.7	1.0	9.6	0.2	1.2	12.9±0.6	255	8.02
2	4	02T025	2.5	2.2	0.7	1.0	14.9	0.3	1.5	19.3±0.6	530	8.02
3	6	03T025	2.5	2.2	0.7	1.0	15.7	0.3	1.5	20.1±0.6	630	8.02
4	8	04T025	2.5	2.2	0.7	1.0	17.0	0.3	1.5	21.4±0.6	745	8.02
5	10	05T025	2.5	2.2	0.7	1.0	18.8	0.3	1.6	23.4±0.6	885	8.02
6	12	06T025	2.5	2.2	0.7	1.0	20.6	0.3	1.7	25.4±1.0	1,035	8.02
7	14	07T025	2.5	2.2	0.7	1.0	20.6	0.3	1.7	25.4±1.0	1,095	8.02
8	16	08T025	2.5	2.2	0.7	1.0	22.8	0.3	1.8	27.8±1.1	1,240	8.02
9	18	09T025	2.5	2.2	0.7	1.0	24.4	0.3	1.8	29.4±1.2	1,395	8.02
10	20	10T025	2.5	2.2	0.7	1.0	25.8	0.3	1.9	31.0±1.2	1,490	8.02
12	24	12T025	2.5	2.2	0.7	1.0	26.6	0.3	1.9	31.8±1.3	1,665	8.02
14	28	14T025	2.5	2.2	0.7	1.2	28.4	0.3	2.0	33.8±1.4	1,915	8.02
15	30	15T025	2.5	2.2	0.7	1.2	30.6	0.4	2.1	36.6±1.5	2,090	8.02
16	32	16T025	2.5	2.2	0.7	1.2	31.2	0.4	2.1	37.2±1.5	2,245	8.02
18	36	18T025	2.5	2.2	0.7	1.2	33.0	0.4	2.2	39.2±1.6	2,495	8.02
19	38	19T025	2.5	2.2	0.7	1.2	33.4	0.4	2.2	39.6±1.6	2,530	8.02
20	40	20T025	2.5	2.2	0.7	1.2	34.9	0.4	2.3	41.3±1.7	2,710	8.02
21	42	21T025	2.5	2.2	0.7	1.2	36.1	0.4	2.3	42.5±1.7	2,865	8.02
23	46	23T025	2.5	2.2	0.7	1.2	36.7	0.4	2.3	43.1±1.7	3,025	8.02
24	48	24T025	2.5	2.2	0.7	1.4	39.0	0.4	2.4	45.6±1.8	3,205	8.02
27	54	27T025	2.5	2.2	0.7	1.4	39.9	0.4	2.5	46.7±1.9	3,475	8.02
30	60	30T025	2.5	2.2	0.7	1.4	41.5	0.4	2.5	48.3±1.9	3,795	8.02
32	64	32T025	2.5	2.2	0.7	1.4	42.7	0.4	2.6	49.7±2.0	4,015	8.02
37	74	37T025	2.5	2.2	0.7	1.4	44.8	0.4	2.7	52.0±2.1	4,470	8.02

Example) 250V BFOU(C) 1Pr x 2.5mm² Part No. QVXA01P025

Q NEK606	V BFOU(C)	X Fire resistant	A 150/250V	01P No. of Triad	025 Size (mm ²)
--------------------	---------------------	----------------------------	----------------------	----------------------------	---------------------------------------

High Voltage Flame Retardant Cable

High Voltage Flame & Fire Resistant Cable

Low Voltage Flame Retardant Cable

Low Voltage Flame & Fire Resistant Cable

Technical information

250V Armored Flame & Fire resistant, Halogen free collectively screened Instrument Cable (Code : 250V BFOU(C)[S104])

No. of Triad	No. of core	Part no.	Conductor		Thickness of insulation	Thickness of inner covering	Nominal dia. over inner covering	Dia. of metal wire for braid	Thickness of outer sheath	Nominal overall dia.	Cable weight approx	Conductor resistance (20°C)
			Nominal sectional area	Max. overall dia.								
Tr	EA	QVXA	mm ²	mm	mm	mm	mm	mm	mm	mm	kg/km	Ω /km
1	3	01T075	0.75	1.2	0.6	1.0	8.0	0.2	1.2	11.3±0.6	190	26.3
2	6	02T075	0.75	1.2	0.6	1.0	12.6	0.3	1.4	16.8±0.6	395	26.3
3	9	03T075	0.75	1.2	0.6	1.0	13.2	0.3	1.4	17.4±0.6	460	26.3
4	12	04T075	0.75	1.2	0.6	1.0	14.4	0.3	1.4	18.6±0.6	535	26.3
5	15	05T075	0.75	1.2	0.6	1.0	15.8	0.3	1.5	20.2±0.6	630	26.3
6	18	06T075	0.75	1.2	0.6	1.0	17.9	0.3	1.6	22.5±0.6	730	26.3
7	21	07T075	0.75	1.2	0.6	1.0	17.9	0.3	1.6	22.5±0.6	765	26.3
8	24	08T075	0.75	1.2	0.6	1.0	19.3	0.3	1.6	23.9±0.6	865	26.3
9	27	09T075	0.75	1.2	0.6	1.0	20.8	0.3	1.7	25.6±1.0	980	26.3
10	30	10T075	0.75	1.2	0.6	1.0	22.5	0.3	1.8	27.5±1.1	1,045	26.3
12	36	12T075	0.75	1.2	0.6	1.0	23.4	0.3	1.8	28.4±1.1	1,175	26.3
14	42	14T075	0.75	1.2	0.6	1.0	24.5	0.3	1.8	29.5±1.2	1,305	26.3
15	45	15T075	0.75	1.2	0.6	1.0	25.4	0.3	1.9	30.6±1.2	1,390	26.3
16	48	16T075	0.75	1.2	0.6	1.0	26.3	0.3	1.9	31.5±1.3	1,460	26.3
18	54	18T075	0.75	1.2	0.6	1.2	28.0	0.3	2.0	33.4±1.3	1,630	26.3
19	57	19T075	0.75	1.2	0.6	1.2	28.3	0.3	2.0	33.7±1.3	1,670	26.3
20	60	20T075	0.75	1.2	0.6	1.2	29.2	0.3	2.0	34.6±1.4	1,775	26.3
21	63	21T075	0.75	1.2	0.6	1.2	29.8	0.3	2.0	35.2±1.4	1,855	26.3
23	69	23T075	0.75	1.2	0.6	1.2	31.1	0.4	2.1	37.1±1.5	2,060	26.3
24	72	24T075	0.75	1.2	0.6	1.2	31.8	0.4	2.1	37.8±1.5	2,120	26.3
27	81	27T075	0.75	1.2	0.6	1.2	33.6	0.4	2.2	39.8±1.6	2,335	26.3
30	90	30T075	0.75	1.2	0.6	1.2	35.2	0.4	2.3	41.6±1.7	2,535	26.3
32	96	32T075	0.75	1.2	0.6	1.2	36.3	0.4	2.3	42.7±1.7	2,700	26.3
1	3	01T001	1.0	1.4	0.6	1.0	8.3	0.2	1.2	11.6±0.6	205	19.3
2	6	02T001	1.0	1.4	0.6	1.0	13.0	0.3	1.4	17.2±0.6	425	19.3
3	9	03T001	1.0	1.4	0.6	1.0	13.6	0.3	1.4	17.8±0.6	490	19.3
4	12	04T001	1.0	1.4	0.6	1.0	14.8	0.3	1.4	19.0±0.6	575	19.3
5	15	05T001	1.0	1.4	0.6	1.0	16.3	0.3	1.5	20.7±0.6	675	19.3
6	18	06T001	1.0	1.4	0.6	1.0	18.4	0.3	1.6	23.0±0.6	795	19.3
7	21	07T001	1.0	1.4	0.6	1.0	18.4	0.3	1.6	23.0±0.6	840	19.3
8	24	08T001	1.0	1.4	0.6	1.0	19.9	0.3	1.7	24.7±0.6	940	19.3
9	27	09T001	1.0	1.4	0.6	1.0	21.4	0.3	1.7	26.2±1.0	1,060	19.3
10	30	10T001	1.0	1.4	0.6	1.0	23.2	0.3	1.8	28.2±1.1	1,140	19.3
12	36	12T001	1.0	1.4	0.6	1.0	24.1	0.3	1.8	29.1±1.2	1,275	19.3
14	42	14T001	1.0	1.4	0.6	1.0	25.3	0.3	1.9	30.5±1.2	1,415	19.3
15	45	15T001	1.0	1.4	0.6	1.0	26.2	0.3	1.9	31.4±1.3	1,525	19.3
16	48	16T001	1.0	1.4	0.6	1.2	27.4	0.3	2.0	32.8±1.3	1,595	19.3
18	54	18T001	1.0	1.4	0.6	1.2	28.9	0.3	2.0	34.3±1.4	1,790	19.3
19	57	19T001	1.0	1.4	0.6	1.2	29.2	0.3	2.0	34.6±1.4	1,820	19.3
20	60	20T001	1.0	1.4	0.6	1.2	30.1	0.4	2.1	36.1±1.4	1,935	19.3
21	63	21T001	1.0	1.4	0.6	1.2	30.8	0.4	2.1	36.8±1.5	2,025	19.3
23	69	23T001	1.0	1.4	0.6	1.2	32.1	0.4	2.2	38.3±1.5	2,245	19.3
24	72	24T001	1.0	1.4	0.6	1.2	32.8	0.4	2.2	39.0±1.6	2,315	19.3
27	81	27T001	1.0	1.4	0.6	1.2	34.6	0.4	2.3	41.0±1.6	2,550	19.3
30	90	30T001	1.0	1.4	0.6	1.4	36.4	0.4	2.3	42.8±1.7	2,790	19.3
32	96	32T001	1.0	1.4	0.6	1.4	37.8	0.4	2.4	44.4±1.8	2,950	19.3

Example) 250V BFOU(C) 1Tr x 0.75mm² Part No. QVXA01T075

Q NEK606	V BFOU(C)	X Fire resistant	A 150/250V	01T No. of Triad	075 Size (mm ²)
--------------------	---------------------	----------------------------	----------------------	----------------------------	---------------------------------------

250V Armored Flame & Fire resistant, Halogen free collectively screened Instrument Cable (Code : 250V BFOU(C)[S104])

No. of Triad	No. of core	Part no.	Conductor		Thickness of insulation	Thickness of inner covering	Nominal dia. over inner covering	Dia. of metal wire for braid	Thickness of outer sheath	Nominal overall dia.	Cable weight approx	Conductor resistance (20°C)
			Nominal sectional area	Max. overall dia.								
Tr	EA	QVXA	mm ²	mm	mm	mm	mm	mm	mm	mm	kg/km	Ω /km
1	3	01T01 ₅	1.5	1.7	0.7	1.0	9.3	0.2	1.2	12.6±0.6	250	12.9
2	6	02T01 ₅	1.5	1.7	0.7	1.0	14.9	0.3	1.5	19.3±0.6	520	12.9
3	9	03T01 ₅	1.5	1.7	0.7	1.0	15.6	0.3	1.5	20.0±0.6	620	12.9
4	12	04T01 ₅	1.5	1.7	0.7	1.0	17.0	0.3	1.5	21.4±0.6	735	12.9
5	15	05T01 ₅	1.5	1.7	0.7	1.0	18.7	0.3	1.6	23.3±0.6	870	12.9
6	18	06T01 ₅	1.5	1.7	0.7	1.0	21.2	0.3	1.7	26.0±1.0	1,035	12.9
7	21	07T01 ₅	1.5	1.7	0.7	1.0	21.2	0.3	1.7	26.0±1.0	1,095	12.9
8	24	08T01 ₅	1.5	1.7	0.7	1.0	22.9	0.3	1.8	27.9±1.1	1,230	12.9
9	27	09T01 ₅	1.5	1.7	0.7	1.0	24.7	0.3	1.8	29.7±1.2	1,380	12.9
10	30	10T01 ₅	1.5	1.7	0.7	1.2	27.1	0.3	1.9	32.3±1.3	1,495	12.9
12	36	12T01 ₅	1.5	1.7	0.7	1.2	28.1	0.3	2.0	33.5±1.3	1,715	12.9
14	42	14T01 ₅	1.5	1.7	0.7	1.2	29.5	0.3	2.0	34.9±1.4	1,920	12.9
15	45	15T01 ₅	1.5	1.7	0.7	1.2	30.6	0.4	2.1	36.6±1.5	2,045	12.9
16	48	16T01 ₅	1.5	1.7	0.7	1.2	31.6	0.4	2.1	37.6±1.5	2,235	12.9
18	54	18T01 ₅	1.5	1.7	0.7	1.2	33.4	0.4	2.2	39.6±1.6	2,475	12.9
19	57	19T01 ₅	1.5	1.7	0.7	1.2	33.7	0.4	2.2	39.9±1.6	2,515	12.9
20	60	20T01 ₅	1.5	1.7	0.7	1.2	34.8	0.4	2.3	41.2±1.7	2,680	12.9
21	63	21T01 ₅	1.5	1.7	0.7	1.2	35.6	0.4	2.3	42.0±1.8	2,825	12.9
23	69	23T01 ₅	1.5	1.7	0.7	1.4	37.4	0.4	2.4	44.0±1.8	3,005	12.9
24	72	24T01 ₅	1.5	1.7	0.7	1.4	38.2	0.4	2.4	44.8±1.9	3,095	12.9
27	81	27T01 ₅	1.5	1.7	0.7	1.4	40.3	0.4	2.5	47.1±2.0	3,455	12.9
30	90	30T01 ₅	1.5	1.7	0.7	1.4	42.4	0.4	2.6	49.4±2.0	3,785	12.9
32	96	32T01 ₅	1.5	1.7	0.7	1.4	43.7	0.4	2.6	50.7±2.0	4,030	12.9
1	3	01T02 ₅	2.5	2.2	0.7	1.0	10.2	0.3	1.3	14.2±0.6	300	8.02
2	6	02T02 ₅	2.5	2.2	0.7	1.0	16.3	0.3	1.5	20.7±0.6	640	8.02
3	9	03T02 ₅	2.5	2.2	0.7	1.0	17.1	0.3	1.5	21.5±0.6	760	8.02
4	12	04T02 ₅	2.5	2.2	0.7	1.0	18.7	0.3	1.6	23.3±0.6	930	8.02
5	15	05T02 ₅	2.5	2.2	0.7	1.0	20.6	0.3	1.7	25.4±1.0	1,105	8.02
6	18	06T02 ₅	2.5	2.2	0.7	1.0	23.4	0.3	1.8	28.4±1.1	1,310	8.02
7	21	07T02 ₅	2.5	2.2	0.7	1.0	23.4	0.3	1.8	28.4±1.1	1,395	8.02
8	24	08T02 ₅	2.5	2.2	0.7	1.0	25.3	0.3	1.9	30.5±1.2	1,575	8.02
9	27	09T02 ₅	2.5	2.2	0.7	1.2	27.6	0.3	2.0	33.0±1.3	1,770	8.02
10	30	10T02 ₅	2.5	2.2	0.7	1.2	29.9	0.3	2.1	35.5±1.4	1,940	8.02
12	36	12T02 ₅	2.5	2.2	0.7	1.2	31.1	0.4	2.1	37.1±1.5	2,285	8.02
14	42	14T02 ₅	2.5	2.2	0.7	1.2	32.6	0.4	2.2	38.8±1.6	2,560	8.02
15	45	15T02 ₅	2.5	2.2	0.7	1.2	33.8	0.4	2.2	40.0±1.6	2,755	8.02
16	48	16T02 ₅	2.5	2.2	0.7	1.2	35.0	0.4	2.3	41.4±1.7	2,885	8.02
18	54	18T02 ₅	2.5	2.2	0.7	1.2	36.9	0.4	2.3	43.3±1.7	3,200	8.02
19	57	19T02 ₅	2.5	2.2	0.7	1.4	37.6	0.4	2.4	44.2±1.8	3,265	8.02
20	60	20T02 ₅	2.5	2.2	0.7	1.4	38.8	0.4	2.4	45.4±1.8	3,530	8.02
21	63	21T02 ₅	2.5	2.2	0.7	1.4	39.7	0.4	2.5	46.5±1.9	3,700	8.02
23	69	23T02 ₅	2.5	2.2	0.7	1.4	41.4	0.4	2.5	48.2±1.9	3,970	8.02
24	72	24T02 ₅	2.5	2.2	0.7	1.4	42.3	0.4	2.6	49.3±2.0	4,095	8.02
27	81	27T02 ₅	2.5	2.2	0.7	1.4	44.7	0.4	2.7	51.9±2.1	4,525	8.02
30	90	30T02 ₅	2.5	2.2	0.7	1.4	46.9	0.4	2.7	54.1±2.2	4,970	8.02
32	96	32T02 ₅	2.5	2.2	0.7	1.6	48.8	0.4	2.8	56.2±2.2	5,295	8.02

Example) 250V BFOU(C) 1Tr x 1.5mm² Part No. QVXA01T01₅

Q NEK606	V BFOU(C)	X Fire resistant	A 150/250V	01T No. of Triad	015 Size (mm ²)
--------------------	---------------------	----------------------------	----------------------	----------------------------	---------------------------------------

High Voltage Flame Retardant Cable

High Voltage Flame & Fire Resistant Cable

Low Voltage Flame Retardant Cable

Low Voltage Flame & Fire Resistant Cable

Technical information

LV Instrument cables | Armored Flame & Fire Resistant, Halogen free Individually screened Instrument Cables (250V BFOU(I), BFOU(I/C))



Application

- Instrument circuit up to 250V, instrument safe systems.
- Fixed installation for instrument, communication, control and alarm systems in both explosion risk and safe areas, emergency and critical systems.
- Maximum operating conductor temperature 90°C

Construction Details

- 1 Conductor** : Circular tinned stranded copper wires as per IEC 60228 class 2 or class5 & IEC 60092-376
- 2 Insulation** : Mica tape and Halogen-free Ethylene propylene rubber (EPR) as per IEC 60092-360
- 3 Pair/triple twisting** : Two/three insulated cores twisted together with suitable lay length
- 4 Individual screening** : Wrapped by copper or aluminium backed polyester tape with tinned copper drain wire
- 5 Core assembly** : Screened pairs/triples are laid up with non-hygroscopic fillers and the binder tape may be applicable
- 6 Collective screening(I/C)** : Wrapped by copper or aluminium backed polyester tape with tinned copper drain wire
- 7 Bedding** : Halogen-free compound (Inner covering)
- 8 Armor** : Copper wires braid(screen) as per IEC 60092-376
— BFCU(option) : Galvanized steel wire braid as per IEC 60092-376
- 9 Outer Sheath** : Halogen-free thermosetting compound as per IEC 60092-360, SHF2 or SHF2 Oil & Mud

Standards Applied

- **Design guideline** : IEC 60092-376, NEK606
- **Material properties** : IEC 60092-360, Insulation (EPR)
IEC 60092-360, Sheath (SHF2)
- **Flame retardant** : IEC 60332-3, Cat. 'A'
- **Fire resistant** : IEC 60331-1/2, at 830°C for 120 min.
(option) waterspray for 15min
- **Assessment of halogen** : IEC 60754-1/2 & 60684-2
- **Low smoke properties** : IEC 61034-1/2
- **Sunlight resistance** : UL 1581
- **Cold properties(option)** : CSA C22.2 No. 03. Cold bending(-50°C), Cold impact(-50°C)
- **Oil/Mud resistance(option)** : NEK TS 606 5th ed (Category a, b, c, d)

Approvals

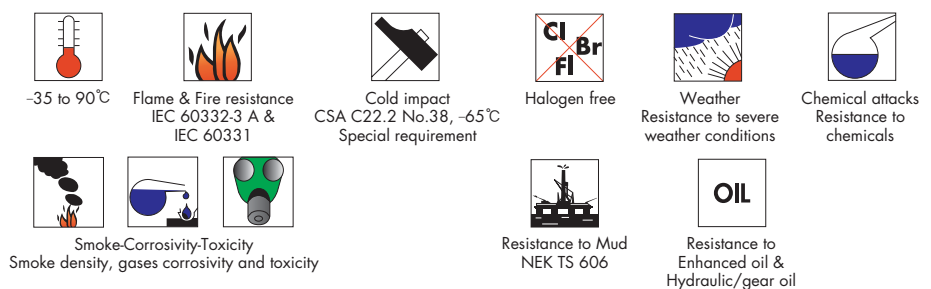

250V Armored Flame & Fire resistant, Halogen free Individually screend Instrument Cable
(Code : 250V BFOU(I)[S3 103], BFOU(I/C)]

No. of pair	No. of core	Part no.	Conductor		Thickness of insulation	Thickness of inner covering	Nominal dia. over inner covering	Dia. of metal wire for braid	Thickness of outer sheath	Nominal overall dia.	Cable weight approx	Conductor resistance (20°C)
			Nominal sectional area	Max. overall dia.								
Pr	EA	QSXA	mm ²	mm	mm	mm	mm	mm	mm	mm	kg/km	Ω /km
1	2	01P075	0.75	1.2	0.6	1.0	7.6	0.2	1.1	10.7±0.6	175	26.3
2	4	02P075	0.75	1.2	0.6	1.0	11.9	0.3	1.3	15.9±0.6	375	26.3
3	6	03P075	0.75	1.2	0.6	1.0	12.5	0.3	1.4	16.7±0.6	430	26.3
4	8	04P075	0.75	1.2	0.6	1.0	13.5	0.3	1.4	17.7±0.6	510	26.3
5	10	05P075	0.75	1.2	0.6	1.0	14.9	0.3	1.5	19.3±0.6	590	26.3
6	12	06P075	0.75	1.2	0.6	1.0	16.3	0.3	1.5	20.7±0.6	685	26.3
7	14	07P075	0.75	1.2	0.6	1.0	16.3	0.3	1.5	20.7±0.6	720	26.3
8	16	08P075	0.75	1.2	0.6	1.0	18.0	0.3	1.6	22.6±0.6	825	26.3
9	18	09P075	0.75	1.2	0.6	1.0	19.2	0.3	1.6	23.8±0.6	920	26.3
10	20	10P075	0.75	1.2	0.6	1.0	20.3	0.3	1.7	25.1±1.0	970	26.3
12	24	12P075	0.75	1.2	0.6	1.0	20.9	0.3	1.7	25.7±1.0	1,090	26.3
14	28	14P075	0.75	1.2	0.6	1.0	22.0	0.3	1.7	26.8±1.1	1,215	26.3
15	30	15P075	0.75	1.2	0.6	1.0	23.7	0.3	1.8	28.7±1.1	1,325	26.3
16	32	16P075	0.75	1.2	0.6	1.0	24.2	0.3	1.8	29.2±1.2	1,380	26.3
18	36	18P075	0.75	1.2	0.6	1.0	25.6	0.3	1.9	30.8±1.2	1,515	26.3
19	38	19P075	0.75	1.2	0.6	1.0	25.9	0.3	1.9	31.1±1.2	1,550	26.3
20	40	20P075	0.75	1.2	0.6	1.2	27.4	0.3	2.0	32.8±1.3	1,660	26.3
21	42	21P075	0.75	1.2	0.6	1.2	28.2	0.3	2.0	33.6±1.3	1,780	26.3
23	46	23P075	0.75	1.2	0.6	1.2	28.7	0.3	2.0	34.1±1.4	1,875	26.3
24	48	24P075	0.75	1.2	0.6	1.2	30.3	0.4	2.1	36.3±1.5	1,950	26.3
27	54	27P075	0.75	1.2	0.6	1.2	31.0	0.4	2.1	37.0±1.5	2,130	26.3
30	60	30P075	0.75	1.2	0.6	1.2	32.2	0.4	2.2	38.4±1.5	2,390	26.3
32	64	32P075	0.75	1.2	0.6	1.2	33.1	0.4	2.2	39.3±1.6	2,540	26.3
37	74	37P075	0.75	1.2	0.6	1.2	34.8	0.4	2.3	41.2±1.6	2,805	26.3

Example) 250V BFOU(I) 1Pr x 0.75mm² Part No. QVXA01P0075

Q NEK606	S BFOU(I)	X Fire resistant	A 150/250V	01P No. of Pair	0075 Size (mm ²)
--------------------	---------------------	----------------------------	----------------------	---------------------------	--

High Voltage Flame Retardant Cable

High Voltage Flame & Fire Resistant Cable

Low Voltage Flame Retardant Cable

Low Voltage Flame & Fire Resistant Cable

Technical information

250V Armored Flame & Fire resistant, Halogen free Individually screened Instrument Cable
(Code : 250V BFOU(I)[S3103], BFOU(I/C)]

No. of pair	No. of core	Part no.	Conductor		Thickness of insulation	Thickness of inner covering	Nominal dia. over inner covering	Dia. of metal wire for braid	Thickness of outer sheath	Nominal overall dia.	Cable weight approx	Conductor resistance (20°C)
			Nominal sectional area	Max. overall dia.								
Pr	EA	QSXA	mm ²	mm	mm	mm	mm	mm	mm	mm	kg/km	Ω /km
1	2	01P001	1.0	1.4	0.6	1.0	7.8	0.2	1.1	10.9±0.6	185	19.3
2	4	02P001	1.0	1.4	0.6	1.0	12.2	0.3	1.3	16.2±0.6	400	19.3
3	6	03P001	1.0	1.4	0.6	1.0	12.8	0.3	1.4	17.0±0.6	470	19.3
4	8	04P001	1.0	1.4	0.6	1.0	13.9	0.3	1.4	18.1±0.6	550	19.3
5	10	05P001	1.0	1.4	0.6	1.0	15.3	0.3	1.5	19.7±0.6	650	19.3
6	12	06P001	1.0	1.4	0.6	1.0	16.8	0.3	1.5	21.2±0.6	745	19.3
7	14	07P001	1.0	1.4	0.6	1.0	16.8	0.3	1.5	21.2±0.6	785	19.3
8	16	08P001	1.0	1.4	0.6	1.0	18.5	0.3	1.6	23.1±0.6	900	19.3
9	18	09P001	1.0	1.4	0.6	1.0	19.8	0.3	1.6	24.4±0.6	1,000	19.3
10	20	10P001	1.0	1.4	0.6	1.0	20.9	0.3	1.7	25.7±1.0	1,070	19.3
12	24	12P001	1.0	1.4	0.6	1.0	21.5	0.3	1.7	26.3±1.1	1,190	19.3
14	28	14P001	1.0	1.4	0.6	1.0	22.7	0.3	1.8	27.7±1.1	1,330	19.3
15	30	15P001	1.0	1.4	0.6	1.0	24.5	0.3	1.8	29.5±1.2	1,450	19.3
16	32	16P001	1.0	1.4	0.6	1.0	24.9	0.3	1.9	30.1±1.2	1,510	19.3
18	36	18P001	1.0	1.4	0.6	1.0	26.4	0.3	1.9	31.6±1.3	1,680	19.3
19	38	19P001	1.0	1.4	0.6	1.2	27.0	0.3	1.9	32.2±1.3	1,705	19.3
20	40	20P001	1.0	1.4	0.6	1.2	28.2	0.3	2.0	33.6±1.3	1,865	19.3
21	42	21P001	1.0	1.4	0.6	1.2	29.1	0.3	2.0	34.5±1.4	1,955	19.3
23	46	23P001	1.0	1.4	0.6	1.2	29.6	0.3	2.0	35.0±1.4	2,060	19.3
24	48	24P001	1.0	1.4	0.6	1.2	31.2	0.4	2.1	37.2±1.5	2,240	19.3
27	54	27P001	1.0	1.4	0.6	1.2	32.0	0.4	2.2	38.2±1.5	2,425	19.3
30	60	30P001	1.0	1.4	0.6	1.2	33.2	0.4	2.2	39.4±1.6	2,650	19.3
32	64	32P001	1.0	1.4	0.6	1.2	34.1	0.4	2.2	40.3±1.6	2,800	19.3
37	74	37P001	1.0	1.4	0.6	1.2	35.8	0.4	2.3	42.2±1.7	3,115	19.3
1	2	01P015	1.5	1.7	0.7	1.0	8.8	0.2	1.2	12.1±0.6	220	12.9
2	4	02P015	1.5	1.7	0.7	1.0	13.9	0.3	1.4	18.1±0.6	485	12.9
3	6	03P015	1.5	1.7	0.7	1.0	14.6	0.3	1.4	18.8±0.6	570	12.9
4	8	04P015	1.5	1.7	0.7	1.0	15.8	0.3	1.5	20.2±0.6	685	12.9
5	10	05P015	1.5	1.7	0.7	1.0	17.5	0.3	1.6	22.1±0.6	800	12.9
6	12	06P015	1.5	1.7	0.7	1.0	19.2	0.3	1.6	23.8±0.6	935	12.9
7	14	07P015	1.5	1.7	0.7	1.0	19.2	0.3	1.6	23.8±0.6	990	12.9
8	16	08P015	1.5	1.7	0.7	1.0	21.2	0.3	1.7	26.0±1.0	1,135	12.9
9	18	09P015	1.5	1.7	0.7	1.0	22.7	0.3	1.8	27.7±1.1	1,260	12.9
10	20	10P015	1.5	1.7	0.7	1.0	23.9	0.3	1.8	28.9±1.2	1,345	12.9
12	24	12P015	1.5	1.7	0.7	1.0	24.7	0.3	1.8	29.7±1.2	1,510	12.9
14	28	14P015	1.5	1.7	0.7	1.0	26.1	0.3	1.9	31.3±1.3	1,710	12.9
15	30	15P015	1.5	1.7	0.7	1.2	28.4	0.3	2.0	33.8±1.4	1,890	12.9
16	32	16P015	1.5	1.7	0.7	1.2	29.0	0.3	2.0	34.4±1.4	1,965	12.9
18	36	18P015	1.5	1.7	0.7	1.2	30.6	0.4	2.1	36.6±1.5	2,185	12.9
19	38	19P015	1.5	1.7	0.7	1.2	31.0	0.4	2.1	37.0±1.5	2,295	12.9
20	40	20P015	1.5	1.7	0.7	1.2	32.4	0.4	2.2	38.6±1.5	2,460	12.9
21	42	21P015	1.5	1.7	0.7	1.2	33.5	0.4	2.2	39.7±1.6	2,595	12.9
23	46	23P015	1.5	1.7	0.7	1.2	34.0	0.4	2.2	40.2±1.6	2,740	12.9
24	48	24P015	1.5	1.7	0.7	1.2	35.9	0.4	2.3	42.3±1.7	2,875	12.9
27	54	27P015	1.5	1.7	0.7	1.2	36.8	0.4	2.3	43.2±1.7	3,120	12.9
30	60	30P015	1.5	1.7	0.7	1.4	38.5	0.4	2.4	45.1±1.8	3,445	12.9
32	64	32P015	1.5	1.7	0.7	1.4	39.6	0.4	2.5	46.4±1.9	3,645	12.9
37	74	37P015	1.5	1.7	0.7	1.4	41.6	0.4	2.5	48.4±1.9	4,055	12.9

Example) 250V BFOU(I) 1Pr x 1.0mm² Part No. QSXA01P001

Q NEK606	S BFOU(I)	X Fire resistant	A 150/250V	01P No. of Pair	001 Size (mm ²)
--------------------	---------------------	----------------------------	----------------------	---------------------------	---------------------------------------

250V Armored Flame & Fire resistant, Halogen free Individually screend Instrument Cable
(Code : 250V BFOU(I)[S3103], BFOU(I/C)]

No. of pair	No. of core	Part no.	Conductor		Thickness of insulation	Thickness of inner covering	Nominal dia. over inner covering	Dia. of metal wire for braid	Thickness of outer sheath	Nominal overall dia.	Cable weight approx	Conductor resistance (20°C)
			Nominal sectional area	Max. overall dia.								
Pr	EA	QSXA	mm ²	mm	mm	mm	mm	mm	mm	mm	kg/km	Ω /km
1	2	01T025	2.5	2.2	0.7	1.0	9.6	0.2	1.2	12.9±0.6	260	8.02
2	4	02T025	2.5	2.2	0.7	1.0	15.2	0.3	1.5	19.6±0.6	585	8.02
3	6	03T025	2.5	2.2	0.7	1.0	16.0	0.3	1.5	20.4±0.6	700	8.02
4	8	04T025	2.5	2.2	0.7	1.0	17.3	0.3	1.5	21.7±0.6	835	8.02
5	10	05T025	2.5	2.2	0.7	1.0	19.2	0.3	1.6	23.8±0.6	1,000	8.02
6	12	06T025	2.5	2.2	0.7	1.0	21.1	0.3	1.7	25.9±1.0	1,165	8.02
7	14	07T025	2.5	2.2	0.7	1.0	21.1	0.3	1.7	25.9±1.0	1,245	8.02
8	16	08T025	2.5	2.2	0.7	1.0	23.3	0.3	1.8	28.3±1.1	1,425	8.02
9	18	09T025	2.5	2.2	0.7	1.0	25.0	0.3	1.9	30.2±1.2	1,585	8.02
10	20	10T025	2.5	2.2	0.7	1.0	26.4	0.3	1.9	31.6±1.3	1,700	8.02
12	24	12T025	2.5	2.2	0.7	1.2	27.5	0.3	2.0	32.9±1.3	1,915	8.02
14	28	14T025	2.5	2.2	0.7	1.2	29.0	0.3	2.0	34.4±1.4	2,205	8.02
15	30	15T025	2.5	2.2	0.7	1.2	31.3	0.4	2.1	37.3±1.5	2,475	8.02
16	32	16T025	2.5	2.2	0.7	1.2	31.9	0.4	2.1	37.9±1.5	2,580	8.02
18	36	18T025	2.5	2.2	0.7	1.2	33.8	0.4	2.2	40.0±1.6	2,865	8.02
19	38	19T025	2.5	2.2	0.7	1.2	34.2	0.4	2.2	40.4±1.6	2,920	8.02
20	40	20T025	2.5	2.2	0.7	1.2	35.8	0.4	2.3	42.2±1.7	3,145	8.02
21	42	21T025	2.5	2.2	0.7	1.2	36.9	0.4	2.3	43.3±1.7	3,305	8.02
23	46	23T025	2.5	2.2	0.7	1.4	37.9	0.4	2.4	44.5±1.8	3,495	8.02
24	48	24T025	2.5	2.2	0.7	1.4	39.9	0.4	2.5	46.7±1.9	3,695	8.02
27	54	27T025	2.5	2.2	0.7	1.4	40.9	0.4	2.5	47.7±1.9	4,050	8.02
30	60	30T025	2.5	2.2	0.7	1.4	42.5	0.4	2.6	49.5±2.0	4,410	8.02
32	64	32T025	2.5	2.2	0.7	1.4	43.7	0.4	2.6	50.7±2.0	4,695	8.02
37	74	37T025	2.5	2.2	0.7	1.4	45.9	0.4	2.7	53.1±2.1	5,245	8.02

Example) 250V BFOU(I) 1Pr x 2.5mm² Part No. QSXA01P025

Q NEK606	S BFOU(I)	X Fire resistant	A 150/250V	01P No. of Pair	025 Size (mm ²)
--------------------	---------------------	----------------------------	----------------------	---------------------------	---------------------------------------

High Voltage Flame Retardant Cable

High Voltage Flame & Fire Resistant Cable

Low Voltage Flame Retardant Cable

Low Voltage Flame & Fire Resistant Cable

Technical information

250V Armored Flame & Fire resistant, Halogen free Individually screened Instrument Cable
(Code : 250V BFOU(I)[S3103], BFOU(I/C)]

No. of Triad	No. of core	Part no.	Conductor		Thickness of insulation	Thickness of inner covering	Nominal dia. over inner covering	Dia. of metal wire for braid	Thickness of outer sheath	Nominal overall dia.	Cable weight approx	Conductor resistance (20°C)
			Nominal sectional area	Max. overall dia.								
Tr	EA	QSXA	mm ²	mm	mm	mm	mm	mm	mm	mm	kg/km	Ω /km
1	3	01T075	0.75	1.2	0.6	1.0	8.0	0.2	1.2	11.3±0.6	200	26.3
2	6	02T075	0.75	1.2	0.6	1.0	13.0	0.3	1.4	17.2±0.6	435	26.3
3	9	03T075	0.75	1.2	0.6	1.0	13.6	0.3	1.4	17.8±0.6	505	26.3
4	12	04T075	0.75	1.2	0.6	1.0	14.8	0.3	1.4	19.0±0.6	595	26.3
5	15	05T075	0.75	1.2	0.6	1.0	16.3	0.3	1.5	20.7±0.6	705	26.3
6	18	06T075	0.75	1.2	0.6	1.0	18.4	0.3	1.6	23.0±0.6	830	26.3
7	21	07T075	0.75	1.2	0.6	1.0	18.4	0.3	1.6	23.0±0.6	875	26.3
8	24	08T075	0.75	1.2	0.6	1.0	19.9	0.3	1.7	24.7±0.6	985	26.3
9	27	09T075	0.75	1.2	0.6	1.0	21.4	0.3	1.7	26.2±1.0	1,105	26.3
10	30	10T075	0.75	1.2	0.6	1.0	23.2	0.3	1.8	28.2±1.1	1,195	26.3
12	36	12T075	0.75	1.2	0.6	1.0	24.1	0.3	1.8	29.1±1.2	1,340	26.3
14	42	14T075	0.75	1.2	0.6	1.0	25.3	0.3	1.9	30.5±1.2	1,495	26.3
15	45	15T075	0.75	1.2	0.6	1.0	26.2	0.3	1.9	31.4±1.3	1,610	26.3
16	48	16T075	0.75	1.2	0.6	1.2	27.4	0.3	2.0	32.8±1.3	1,685	26.3
18	54	18T075	0.75	1.2	0.6	1.2	28.9	0.3	2.0	34.3±1.4	1,890	26.3
19	57	19T075	0.75	1.2	0.6	1.2	29.2	0.3	2.0	34.6±1.4	1,925	26.3
20	60	20T075	0.75	1.2	0.6	1.2	30.1	0.4	2.1	36.1±1.4	2,050	26.3
21	63	21T075	0.75	1.2	0.6	1.2	30.8	0.4	2.1	36.8±1.5	2,140	26.3
23	69	23T075	0.75	1.2	0.6	1.2	32.1	0.4	2.2	38.3±1.5	2,375	26.3
24	72	24T075	0.75	1.2	0.6	1.2	32.8	0.4	2.2	39.0±1.6	2,450	26.3
27	81	27T075	0.75	1.2	0.6	1.2	34.6	0.4	2.3	41.0±1.6	2,700	26.3
30	90	30T075	0.75	1.2	0.6	1.2	36.4	0.4	2.3	42.8±1.7	2,960	26.3
32	96	32T075	0.75	1.2	0.6	1.2	37.8	0.4	2.4	44.4±1.8	3,130	26.3
1	3	01T001	1.0	1.4	0.6	1.0	8.3	0.2	1.2	11.6±0.6	210	19.3
2	6	02T001	1.0	1.4	0.6	1.0	13.4	0.3	1.4	17.6±0.6	465	19.3
3	9	03T001	1.0	1.4	0.6	1.0	14.0	0.3	1.4	18.2±0.6	545	19.3
4	12	04T001	1.0	1.4	0.6	1.0	15.2	0.3	1.5	19.6±0.6	645	19.3
5	15	05T001	1.0	1.4	0.6	1.0	16.8	0.3	1.5	21.2±0.6	760	19.3
6	18	06T001	1.0	1.4	0.6	1.0	19.0	0.3	1.6	23.6±0.6	895	19.3
7	21	07T001	1.0	1.4	0.6	1.0	19.0	0.3	1.6	23.6±0.6	960	19.3
8	24	08T001	1.0	1.4	0.6	1.0	20.5	0.3	1.7	25.3±1.0	1,085	19.3
9	27	09T001	1.0	1.4	0.6	1.0	22.1	0.3	1.7	26.9±1.1	1,205	19.3
10	30	10T001	1.0	1.4	0.6	1.0	23.9	0.3	1.8	28.9±1.2	1,305	19.3
12	36	12T001	1.0	1.4	0.6	1.0	24.8	0.3	1.8	29.8±1.2	1,470	19.3
14	42	14T001	1.0	1.4	0.6	1.0	26.1	0.3	1.9	31.3±1.3	1,655	19.3
15	45	15T001	1.0	1.4	0.6	1.0	27.3	0.3	1.9	32.5±1.3	1,765	19.3
16	48	16T001	1.0	1.4	0.6	1.2	28.2	0.3	2.0	33.6±1.3	1,890	19.3
18	54	18T001	1.0	1.4	0.6	1.2	29.8	0.3	2.0	35.2±1.4	2,080	19.3
19	57	19T001	1.0	1.4	0.6	1.2	30.1	0.4	2.1	36.1±1.4	2,120	19.3
20	60	20T001	1.0	1.4	0.6	1.2	31.0	0.4	2.1	37.0±1.5	2,345	19.3
21	63	21T001	1.0	1.4	0.6	1.2	31.7	0.4	2.1	37.7±1.5	2,455	19.3
23	69	23T001	1.0	1.4	0.6	1.2	33.1	0.4	2.2	39.3±1.6	2,630	19.3
24	72	24T001	1.0	1.4	0.6	1.2	33.8	0.4	2.2	40.0±1.6	2,715	19.3
27	81	27T001	1.0	1.4	0.6	1.2	35.7	0.4	2.3	42.1±1.7	2,995	19.3
30	90	30T001	1.0	1.4	0.6	1.4	37.8	0.4	2.4	44.4±1.8	3,265	19.3
32	96	32T001	1.0	1.4	0.6	1.4	39.0	0.4	2.4	45.6±1.8	3,510	19.3

Example) 250V BFOU(I) 1Tr x 0.75mm² Part No. QSXA01T075

Q NEK606	S BFOU(I)	X Fire resistant	A 150/250V	01T No. of Triad	075 Size (mm ²)
--------------------	---------------------	----------------------------	----------------------	----------------------------	---------------------------------------

250V Armored Flame & Fire resistant, Halogen free Individually screend Instrument Cable
(Code : 250V BFOU(I)[S]103], BFOU(I/C)]

No. of Triad	No. of core	Part no.	Conductor		Thickness of insulation	Thickness of inner covering	Nominal dia. over inner covering	Dia. of metal wire for braid	Thickness of outer sheath	Nominal overall dia.	Cable weight approx	Conductor resistance (20°C)
			Nominal sectional area	Max. overall dia.								
Tr	EA	Q5XA	mm ²	mm	mm	mm	mm	mm	mm	kg/km	Ω /km	
1	3	01T015	1.5	1.7	0.7	1.0	9.3	0.2	1.2	12.6±0.6	250	12.9
2	6	02T015	1.5	1.7	0.7	1.0	15.2	0.3	1.5	19.6±0.6	575	12.9
3	9	03T015	1.5	1.7	0.7	1.0	15.9	0.3	1.5	20.3±0.6	680	12.9
4	12	04T015	1.5	1.7	0.7	1.0	17.4	0.3	1.6	22.0±0.6	810	12.9
5	15	05T015	1.5	1.7	0.7	1.0	19.2	0.3	1.6	23.8±0.6	970	12.9
6	18	06T015	1.5	1.7	0.7	1.0	21.7	0.3	1.7	26.5±1.1	1,145	12.9
7	21	07T015	1.5	1.7	0.7	1.0	21.7	0.3	1.7	26.5±1.1	1,220	12.9
8	24	08T015	1.5	1.7	0.7	1.0	23.5	0.3	1.8	28.5±1.1	1,385	12.9
9	27	09T015	1.5	1.7	0.7	1.0	25.3	0.3	1.9	30.5±1.2	1,545	12.9
10	30	10T015	1.5	1.7	0.7	1.2	27.8	0.3	2.0	33.2±1.3	1,695	12.9
12	36	12T015	1.5	1.7	0.7	1.2	28.8	0.3	2.0	34.2±1.4	1,930	12.9
14	42	14T015	1.5	1.7	0.7	1.2	30.3	0.4	2.1	36.3±1.5	2,165	12.9
15	45	15T015	1.5	1.7	0.7	1.2	31.4	0.4	2.1	37.4±1.5	2,405	12.9
16	48	16T015	1.5	1.7	0.7	1.2	32.4	0.4	2.2	38.6±1.5	2,515	12.9
18	54	18T015	1.5	1.7	0.7	1.2	34.2	0.4	2.2	40.4±1.6	2,795	12.9
19	57	19T015	1.5	1.7	0.7	1.2	34.6	0.4	2.3	41.0±1.6	2,845	12.9
20	60	20T015	1.5	1.7	0.7	1.2	35.7	0.4	2.3	42.1±1.7	3,050	12.9
21	63	21T015	1.5	1.7	0.7	1.2	36.5	0.4	2.3	42.9±1.7	3,190	12.9
23	69	23T015	1.5	1.7	0.7	1.4	38.4	0.4	2.4	45.0±1.8	3,455	12.9
24	72	24T015	1.5	1.7	0.7	1.4	39.2	0.4	2.4	45.8±1.8	3,565	12.9
27	81	27T015	1.5	1.7	0.7	1.4	41.4	0.4	2.5	48.2±1.9	3,940	12.9
30	90	30T015	1.5	1.7	0.7	1.4	43.5	0.4	2.6	50.5±2.0	4,325	12.9
32	96	32T015	1.5	1.7	0.7	1.4	44.9	0.4	2.7	52.1±2.1	4,580	12.9
1	3	01T025	2.5	2.2	0.7	1.0	10.2	0.3	1.3	14.2±0.6	350	8.02
2	6	02T025	2.5	2.2	0.7	1.0	16.7	0.3	1.5	21.1±0.6	685	8.02
3	9	03T025	2.5	2.2	0.7	1.0	17.5	0.3	1.6	22.1±0.6	830	8.02
4	12	04T025	2.5	2.2	0.7	1.0	19.1	0.3	1.6	23.7±0.6	1,020	8.02
5	15	05T025	2.5	2.2	0.7	1.0	21.1	0.3	1.7	25.9±1.0	1,220	8.02
6	18	06T025	2.5	2.2	0.7	1.0	23.9	0.3	1.8	28.9±1.2	1,445	8.02
7	21	07T025	2.5	2.2	0.7	1.0	23.9	0.3	1.8	28.9±1.2	1,550	8.02
8	24	08T025	2.5	2.2	0.7	1.0	25.9	0.3	1.9	31.1±1.2	1,765	8.02
9	27	09T025	2.5	2.2	0.7	1.2	28.2	0.3	2.0	33.6±1.3	2,010	8.02
10	30	10T025	2.5	2.2	0.7	1.2	30.6	0.4	2.1	36.6±1.5	2,180	8.02
12	36	12T025	2.5	2.2	0.7	1.2	31.8	0.4	2.1	37.8±1.5	2,550	8.02
14	42	14T025	2.5	2.2	0.7	1.2	33.4	0.4	2.2	39.6±1.6	2,885	8.02
15	45	15T025	2.5	2.2	0.7	1.2	34.6	0.4	2.3	41.0±1.6	3,080	8.02
16	48	16T025	2.5	2.2	0.7	1.2	35.8	0.4	2.3	42.2±1.7	3,250	8.02
18	54	18T025	2.5	2.2	0.7	1.4	38.1	0.4	2.4	44.7±1.8	3,590	8.02
19	57	19T025	2.5	2.2	0.7	1.4	38.5	0.4	2.4	45.1±1.8	3,725	8.02
20	60	20T025	2.5	2.2	0.7	1.4	39.7	0.4	2.5	46.5±1.9	3,965	8.02
21	63	21T025	2.5	2.2	0.7	1.4	40.6	0.4	2.5	47.4±1.9	4,175	8.02
23	69	23T025	2.5	2.2	0.7	1.4	42.4	0.4	2.6	49.4±2.0	4,460	8.02
24	72	24T025	2.5	2.2	0.7	1.4	43.3	0.4	2.6	50.3±2.0	4,635	8.02
27	81	27T025	2.5	2.2	0.7	1.4	45.7	0.4	2.7	52.9±2.1	5,130	8.02
30	90	30T025	2.5	2.2	0.7	1.6	48.5	0.4	2.8	55.9±2.2	5,610	8.02
32	96	32T025	2.5	2.2	0.7	1.6	50.0	0.4	2.9	57.6±2.3	6,030	8.02

Example) **250V BFOU(I) 1Tr x 1.5mm²** Part No. **Q5XA01T015**

Q NEK606	S BFOU(I)	X Fire resistant	A 150/250V	01T No. of Triad	015 Size (mm ²)
--------------------	---------------------	----------------------------	----------------------	----------------------------	---------------------------------------

High Voltage Flame Retardant Cable

High Voltage Flame & Fire Resistant Cable

Low Voltage Flame Retardant Cable

Low Voltage Flame & Fire Resistant Cable

Technical information



Contents

Nexans Power Accessories 79 ~ 81

Technical Information 82 ~ 114

Installation Recommendation

Electrical Data

Material Properties

Test Method

Drum Capacity

Cable Scale

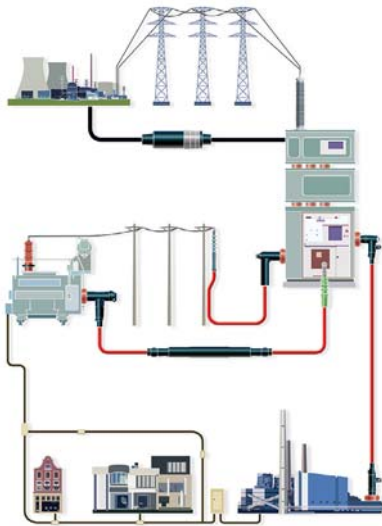

Nexans Power Accessories

Always the right connection

This is where you can find us.

Wherever electricity is conducted through cables and wires. Wherever cables are connected or energy transmission and distribution is required. Wherever safety and quality have priority.

We demonstrate competence.

Nexans products ensure operational reliability as network utilisation increases. Our references include more than 50 years of experience with over 100million connectors and accessories used worldwide.

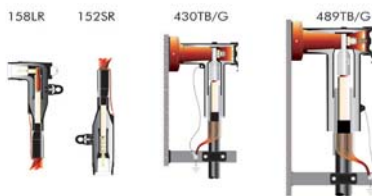

Connectors from 10 kV to 42 kV and 25 mm² to 1200 mm²



Terminations from 10 kV to 42 kV and 25 mm² to 1000 mm²

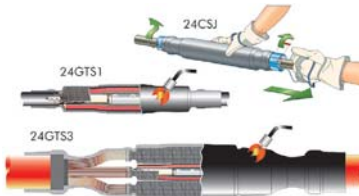

Joints from 10 kV to 42 kV and 25 mm² to 1200 mm²

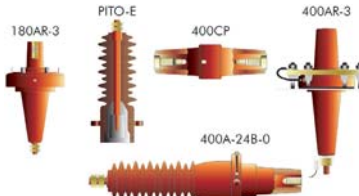

Equipment bushings from 10 kV to 42 kV



Mechanical connectors and compression joints

What you can expect.

Our connectors and accessories have set industry standards and influenced European standards. Quality awareness is a central component of our company philosophy. Our strength lies in pooling the tasks from connection and cabling technology. We show our appreciation for our customers by providing them with expert and dedicated support.

We are certified.

OHRIS, DIN EN ISO 9001: 2008, DIN EN ISO 14001: 2009

We bear responsibility

The Nexans Power Accessories Group currently produces accessories from 1kV to 500kV. As we are the Centre of Competence for cable accessories, we have taken on responsibility for research and development in the Nexans Group for connection technology.

Advancing into the future with "Smart Grid".

Our developments are making a significant contribution to the creation of intelligent control mechanisms for automated energy network structures.

Norms are important to us.

Our accessories meet the requirements of the following standards:

EN 61442, HD 629.1, HD 629.2, EN 50180, EN 50181, IEC 60137, IEEE 386 & 404, IEC 61238-1, VDE 0220 T100, etc.



High Voltage Flame Retardant Cable

High Voltage Flame & Fire Resistant Cable

Low Voltage Flame Retardant Cable

Low Voltage Flame & Fire Resistant Cable

Technical information

Nexans, separable **connectors** leader



- **Premoulded EPDM**, proven stable for years, even when submersed
- **Safe** when touched accidentally
- Each Euromold connector is **factory tested** individually
- **Complete line** of solutions for all standard interfaces up to 42 kV, covering a range of cables from 16mm² up to 1200mm²



Ferrules and lugs for every market segment

- **Wide range** of crimp and mechanical connectors and lugs
- Provides solutions for all **customer** needs
- Pioneers of the bolted mechanical connector



Epoxy resin **equipment bushings** and terminations



- **A large range** of equipment bushings for in-oil, in-air and for plug-in or bolted versions
- Moulded epoxy resin solutions for all **standard interfaces**
- Design and manufacturing of **specific products** requested by the customer
- Each bushing is **tested** prior to leaving the factory individually



Cold-shrinkable straight, transition and cross bonding joints.



- Cold-shrinkable solutions for any **single core** and **three core** cable
- One single movement **installation**
- Solutions for 12, 24 and 36 kV, covering a **range of cables** from 35 mm² up to 1000 mm²
- **Reliable** transition joints for belted and individually screened cables.



Cold applied **terminations** for indoor and outdoor use



- Cold-shrinkable products for **easy installation**
- **Slip-on** products up to 42 kV and 1000 mm²
- Moulded in high quality **silicone rubber**



Heat-shrink products & components **joints and terminations**



- A **full range** of **heat-shrink** joints and terminations, covering a range of cables from 16mm² up to 1200mm²
- High quality non-tracking tubes and stress control tubes provide **long term performance**
- For use in infrastructure, industry and building market segments

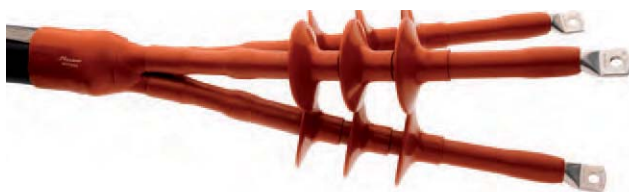

Installation Recommendations

The following installation recommendations are in accordance with IEC 60092-352 and the relevant class regulations;

1. Minimum bending radius

The minimum recommended installation bending radius shall be as following table;

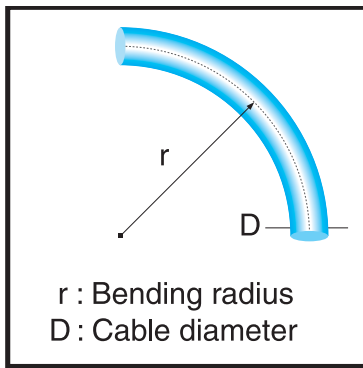

Bending radii for cables rated up to 1, 8/3 kV

Cable construction		Overall diameter of cable (D)	Minimum internal radius of bend
Insulation	Covering		
Thermoplastic or thermosetting with circular copper conductors	Unarmored or unbraided	≤ 25 mm	4D ^a
		> 25 mm	6D
	Metal braid screened or armored	Any	6D
	Metal wire armored	Any	6D
	Metal tape armored or metal - sheathed	Any	8D
	Composite polyester/metal laminate tape screened units or collective tape screening	Any	8D
Thermoplastic or thermosetting with sector shaped copper conductors	Any	Any	8D
Mineral	Hard metal sheathed	Any	6D

^a 6D for defined circuit integrity

Bending radii for cables rated at 3,6/6,0(7,2) kV and above

Cable construction	Overall diameter of cable (D)	Minimum internal radius of bend
Single Core Cable	Any	12D
3 - Core cables	Any	9D

2. Minimum temperature during installation

The minimum recommended temperature during installation cables should not be installed at the following temperature;

- *Medium Voltage Power Cables* -20°C
- *Low Voltage Power Cables* -20°C
- *Low Voltage Control Cables* -20°C

3. Cable pulling tension during installation

The cable pulling tension during installation can be estimated by the following formula;

- *For Armored Cables*
 $Pulling\ Tension(kg) = 5kg \times Total\ Cross\ Section\ of\ Conductors$
- *For Unarmored Cables*
 $Pulling\ Tension(kg) = 2.5kg \times Total\ Cross\ Section\ of\ Conductors$

Additional tension will be supplied from the braid, insulation and sheathing compound.

4. Explosion risk areas

4.1 Areas

The areas on board are usually classified in two main categories as regards the explosion risk ;

- Hazardous areas ; Areas in which explosive gas-air mixtures are, or may be expected to be, present in quantities such as to required special precautions for the construction and use of electrical apparatus.
- Safe areas (non-hazardous areas) ; Areas in which explosive gas-air mixtures are not expected to be present in quantities such as to required special precautions for the construction and use of electrical apparatus.

A hazardous area is divided into three zones ;

- Zone 0 ; in which an explosive gas-air mixture is continuously present or present for long periods.
- Zone 1 ; in which an explosive gas-air mixture is likely to occur in normal operation.
- Zone 2 ; in which an explosive gas-air mixture is not likely to occur, and if occurs it will only exist for a short time.

4.2 Installation of cables

- For cables to be used in zone 0 and zone 1, one of the following types of protection is required ;
 - A non-metallic outer sheath in combination with braiding or other metallic covering for earth fault detection and mechanical protection. A non-metallic outer sheath is, however, not required if the screen or armoring consists of a corrosion resistant bronze alloy.
 - A lead sheathing in addition to further mechanical protection, for example armor braiding or non-metallic impervious sheath.
 - For mineral insulated cables, a copper or stainless steel sheath.
 - Single core cables in installations with A.C. or D.C. current with a high ripple content should be of types without screen or armoring. Where mechanical damage is possible, such cables should otherwise be mechanically protected or installed in ducts or similar.
- For installations in zone 2, cables without screen or armor can be used.

5. Earthing of metal coverings of cables

5.1 General requirements

- All metal coverings of cables, aermoring or shielding shall be earthed. Earthing must be provided at both ends except for final sub-circuits where earthing at only one end at supply is sufficient.
- Earthing at one end is permitted where it is required for technical or safety reasons, control and instrumentation cables, mineral insulated cables, intrinsically safe circuits, control circuits, etc.
- Metal covering of single core cables for A.C. and single core cables for D.C. with ripple content exceeding 10% and having a current rating exceeding 20 ampere are to be earthed at one end only.
- When single core cables for A.C. and D.C. with ripple content higher than 10% are installed in or passing through hazardous areas, the metal screen or armor is to be earthed inside the hazardous area to avoid dangerous potential between armor and earthed installation.

5.2 Cross section of earth connections

- Earth connections for metal coverings shall be carried out with conductors having cross sectional areas related to the cross sectional areas of the phase conductors and the current ratings of the cable, or at least the same cross sectional area as the metal covering itself.

5.3 Earthing through metal clamps, etc.

- Metal covering of cables may be earthed through clamps. The clamps must grip the metal covering of the cable and must be connected to the hull and provide a good conductive connection between the metal covering and the hull. The metal clamps must be corrosion resistant.

5.4 Earthing through cable glands

- The metal coverings of cables may be earthed by means of glands intended for the purpose and so designed as to ensure an effective earth connection. The glands shall be firmly attached to, and in effective electrical contact with, a metal structure earthed in accordance with these regulations.

5.5 Earthing of metal pipes, conduits, etc.

- Metal pipes and cable conduits are to be earthed. Pipes and conduits may be earthed by being screwed into a metal enclosure, or by nuts on both sides of the wall of the metallic enclosure, provided that the surface is clean and free from rust, scale or paint.

Importance

For Intrinsically safe circuits, it is important to separate the earth conductor from the protective earthing. The resistance between a zener barrier earth and protective earth must be max. $1.0\ \Omega$ and preferably less than $0.1\ \Omega$ to avoid that possible fault current does not lead to a potential increase in the system.

6. Fixing of cables

- With the exception of cables for portable appliances and those installed in pipes, conduits, trunkings or special casings, cables shall be fixed by means of clips, saddles or straps of suitable material which if ignited, shall not contribute to any spread of flame along the cables or insulated wire. The material shall have a surface area sufficiently large and be shaped such that the cables remain tight without their coverings being damaged.
- The distances between supports shall be chosen according to the type of cable and the probability of vibration. It shall not exceed 400mm for a horizontal cable run where the cables are laid on cable supports in the form of tray plates, separate support brackets or hanger ladders. The spacing between the fixing points may be up to 900mm, provided that there are supports with maximum spacing as specified above. This exemption shall not apply to cable runs along weather decks, when the cable run is arranged so that the cables can be subjected to forces by water washing over the deck.

Note 1 When designing a cable support system for single core cables consideration shall also be given to the effects of electrodynamic forces developing on the occurrence of a short circuit. The distances between cable supports given above are not necessarily adequate for these forces.

Note 2 Cables with class 5 conductors may require additional support to prevent sagging.

- The supports and the corresponding accessories shall be robust and shall be of corrosion resistant material or suitably treated before erection to resist corrosion.
- When cables are fixed by means of non-metallic clips or straps, and are not laid on top of horizontal cable trays or cable supports, suitable metal cable clips or saddles shall be added at regular distances not greater than 1 m in order to prevent the release of cables during a fire. This also applies to the fixing of non-metallic conduits or pipes.
- Cable clips or straps used to support cable for use in high fire risk areas and safety escape routes shall be metallic.

Note 3 Cable clips or straps made from a material other than metal may be used. Requirements concerning the characteristics of the material are under consideration.

7. Mechanical protection of cables

- Cables are to be installed in such a way that they are not subject to damaging mechanical stresses. Where this can not be obtained, the cables are to be protected.
- Unless the cables itself, for example armor or sheath, provides adequate protection, the cables should be;
 - enclosed in suitable conduits or casings
 - covered by steelplates or profiles
 - steel pipes in which the cables are run.
- In areas which there is an exceptional risk of mechanical damage, for example in cargo hold area or different storage areas, the cables always have to be protected, even when the cables are armored.
- The thickness of the protective conduits must be at least 4.0 mm. The wall thickness of the protective conduit must be at least 2.0 mm.
- Cables laid on aluminum supports may have a corresponding protection of aluminum. The thickness of aluminum supports must be at least 4.0 mm.
- Metal of casing used for mechanical protection of cables should be efficiently protected against corrosion.

8. Installation of cables for fire precaution

- Cables must at least meet the flame retardant requirements. On board passenger ships, cargo ships, mobile offshore and drilling units, where not otherwise stated cables must be installed as not to impair the original flame retarding properties. These requirements are considered to be satisfied if the cables have characteristics complying with the cable bunch test in IEC 60332-3.
- Cables in cable bunches serving essential or emergency power, lighting, signals or internal communications, which pass through galleys, laundries, machine spaces of category A according to SOLAS convention 1974 & its amendments and their casings and other high fire risk areas, shall be required the flame retarding characteristics in accordance with IEC 60332-1 and in addition to be;
 - of a fire resisting type according to IEC60331, and
 - of a non fire propagating type according to Category A of IEC 60332-3, and
 - mechanically protected against casualties which may occur on the site of their installation, unless they are routed clear of such spaces or areas.
- When cables are used which do not pass any of the tests (either category 'A', 'B' or 'C') of IEC 60332-3, the following method of installation may be adopted that the cables;
 - pass the test of IEC 60332-1
 - the fire stops in enclosed or semi-enclosed spaces, as follows;
 - a) For vertical cable run
 - with a max. distance between fire stops of two decks or 6 meters, unless installed in totally enclosed cable trunks.
 - at the main and the emergency switchboards.
 - where cables enter into an engine control room.
 - at centralized control panels for propulsion machinery and essential auxiliaries.
 - at the entrance to cable trunks.
 - b) For horizontal cable run
 - as a) above, but the max. distance between fire stops may be increased to 14 meters.
 - c) In cargo holds and underneck passageways in the cargo area, fire stops need be fitted only at boundaries of the compartment.
- When choosing cable types special attention should be paid to reduce possible damage due to corrosion in case of a fire. Non-halogen free cables will give off corrosive gases during a fire. The corrosion effect depends on the amount of halogens in the materials used.
- Cables connecting fire pumps to the emergency switchboard should be a fire resistant type where they pass through high fire risk areas, such as;
 - cables for emergency power systems e.g. fire pumps.
 - cables for fire extinguishing systems.
 - control cables for water tight doors.
 - control cables for ballast system unless when these are duplicated.
 - essential alarms cables.
 - fire and gas detection systems.
 - cables for lifts.

9. Intrinsically safe installations

- Cables and flexible cables for intrinsically safe circuits must have screen or similar of a conducting material and the outer sheath must be of a non-metallic material. A non-metallic outer sheath is, however, not required if the screen or armor consists of a corrosion resistant bronze alloy. Where there is no danger of interference from the external electrical or magnetic fields, short flexible cables may be used without screen.

9.1 Associated equipment

Associated equipment (e.g. power supply units) shall be situated in a safe area or have protection as mentioned in clause 4 (Explosion risk areas).

9.2 Connection of equipment

Within limitations laid down in 3., ordinary non-explosion protected equipment may be connected to intrinsically safe equipment, provided that it is designed to meet regulations in other respects.

9.3 Compliance with any limitations in the certificate

With intrinsically safe circuits special considerations must be given to ensure that the circuit characteristics (including connected equipment, cables, conductors, etc.) satisfy any limitations in the test certificate. Such limitations may be maximum values for capacitance and inductance, etc. It is pointed out, there is a danger of damage to intrinsically safe equipment when using normal equipment for insulation testing.

9.4 Adjacent location

Conductors for intrinsically safe circuits and conductors for non-intrinsically safe circuits shall not be run together in the same cable, flexible cable, conduit, cable bunch, etc.

9.5 Protection against electrical and magnetic fields

Where intrinsically safe circuits are exposed to magnetic or electrical fields that may destroy the intrinsic safety of the system, precautions must be taken during installation.

Such precautions may be;

- Cables for intrinsically safe circuits and non-intrinsically safe circuits to be installed a minimum distance of 50 mm apart. The minimum distance to heavy current cables using D.C. with a high ripple content should be 300 mm.
- Cables for intrinsically safe circuits and non-intrinsically safe circuits to be separated by a mechanical, separating panel of conducting material which is earthed.
- Cables for intrinsically safe circuits to have effective transposition.

9.6 Marking

The marking may be a marking plate or by color marking of the cables, when using color marking, the color should be light blue.

10. Installation in refrigeration spaces

- Cables to be installed in refrigeration spaces should include an impervious sheath and should be protected against mechanical damage. Cables insulated or sheathed with PVC should not be used in refrigeration spaces unless the relevant PVC compounds are appropriate to the low temperature expected.
- If the armor is made of non-corrosion-resisting material, it should be protected against corrosion by a moisture-resisting and low-temperature resisting covering.
- Cables installed in refrigeration spaces should not be covered by thermal insulation. If a cable has thermoplastic or elastomeric extruded sheath, it may be placed directly on the face of the refrigeration chamber. The casual use of cables as a means of suspension should be obviated by the provision of guards surrounding the cables.
Care should be taken to avoid the possibility of electrolytic action if the refrigeration chamber has an aluminum facing.
- If the cables must pass through the thermal insulation of the compartments, they should do so at right angles, in tubes provided with entries of material protected against oxidation.

11. Special precaution for single-core cables for a.c. wiring

A.C. wiring should be carried out, as far as possible, in twin or multicore cable. When, however, it is necessary to use single-core cables for circuits rated in excess of 20 A, the following precautions should be observed;

- The cables should either be non-armored or they should be armored with non-magnetic material. In order to avoid current loops, the metallic screen should be earthed at one point only.
- Conductors belonging to the same circuit should be contained within the same pipe, conduit or trunking, or the clamps which fix them should include all the phases, unless they are made of non-magnetic material.
- In the installing of two, three, or four single-core cables forming respectively single phase-circuits, three-phase circuits, or three-phase and neutral circuits, the cables should, as far as possible, be in contact with one another.
- In every case, the distance measured between the external covering of two adjacent cables should not be greater than one cable diameter.
- When single-core cables having a current rating greater than 250 A must be installed near a steel bulkhead, the clearance between the cables and the bulkhead should be at least 50 mm, unless the cables belonging to the same A.C. circuit are installed in trefoil formation.
- Magnetic material should not be used between single-core cables of a group. Where cables pass through steel plates, all the conductors of the same circuit should pass through a plate or gland, so made that there is no magnetic material between the cables, and the clearance between the cables and the magnetic material should be not less than 75 mm, unless the cables belonging to the same A.C. circuit are installed in trefoil formation.
- In order to equalize to some degree the impedance of three-phase circuits of considerable length consisting of single-core cables of a conductor cross-section of 185 mm² or over, a transposition of the phases should be effected at intervals not exceeding 15 m.
Alternatively, the cables may be installed in trefoil formation.
The above precautions are, however, not necessary when the length of the run is less than 30m.
- In circuits involving several single-core cables in parallel per phase, all cables should follow the same route and have the same cross-sectional area.

Electrical Data

1. Construction and resistance of conductor

- (1) Resistance Formula; (2) Resistance as a function of temperature

$$R = \rho \frac{L}{A} \qquad R = R_0 [1 + \alpha (t - 20)]$$

R = resistance in ohm per phase R₀ = resistance at t = 20°C
 ρ = specific resistance, Ω · mm²/m t = conductor temperature, °C
 A = conductor area, mm² α = 0.00393 for copper
 L = conductor length, m

- (3) Construction and Resistance in accordance with IEC 60228(BS 6360)

Solid and Stranded copper conductors										
Nominal cross sectional area mm ²	Solid copper (class 1) Conductor diameter (max.) mm	Circular stranded copper (class 2)					Maximum Resistance			
		Non-compacted		Compacted			Plain		Metal coated	
		Minimum number of wires	Conductor diameter (max.) mm	Minimum number of wires	Conductor diameter (min.) mm	Conductor diameter (max.) mm	at 20°C Ω/km	at 90°C Ω/km	at 20°C Ω/km	at 90°C Ω/km
0.5	0.9	7	1.1	-	-	-	36.0	45.9	36.7	46.8
0.75	1.0	7	1.2	-	-	-	24.5	31.2	24.8	31.6
1.0	1.2	7	1.4	-	-	-	18.1	23.1	18.2	23.2
1.5	1.5	7	1.7	-	-	-	12.1	15.4	12.2	15.6
2.5	1.9	7	2.2	-	-	-	7.41	9.45	7.56	9.64
4	2.4	7	2.7	-	-	-	4.61	5.88	4.70	5.99
6	2.9	7	3.3	-	-	-	3.08	3.93	3.11	3.97
10	3.7	7	4.2	-	-	-	1.83	2.33	1.84	2.35
16	4.6	7	5.3	-	-	-	1.15	1.47	1.16	1.48
25	-	7	6.6	6	5.6	6.5	0.727	0.927	0.734	0.936
35	-	7	7.9	6	6.6	7.5	0.524	0.668	0.529	0.674
50	-	19	9.1	6	7.7	8.6	0.387	0.493	0.391	0.499
70	-	19	11.0	12	9.3	10.2	0.286	0.365	0.270	0.344
95	-	19	12.9	15	11.0	12.0	0.193	0.246	0.195	0.249
120	-	37	14.5	18	12.5	13.5	0.153	0.195	0.154	0.196
150	-	37	16.2	18	13.9	15.0	0.124	0.158	0.126	0.161
185	-	37	18.0	30	15.5	16.8	0.0991	0.1264	0.1000	0.128
240	-	61	20.6	34	17.8	19.2	0.0754	0.0961	0.0762	0.097
300	-	61	23.1	34	20.0	21.6	0.0601	0.0766	0.0607	0.077
400	-	61	26.1	53	22.9	24.6	0.04701	0.0599	0.0475	0.061
500	-	61	29.2	53	25.7	27.6	0.0366	0.0467	0.0369	0.047
630	-	91	33.2	53	29.3	32.5	0.0283	0.0361	0.0286	0.037

High Voltage Flame Retardant Cable

High Voltage Flame & Fire Resistant Cable

Low Voltage Flame Retardant Cable

Low Voltage Flame & Fire Resistant Cable

Technical Information

Flexible Copper Conductors

Nominal cross sectional area mm ²	Maximum diameter of Strands		Maximum diameter of conductor	Maximum Resistance			
	Class 5 mm	Class 6 mm		Plain		Metal coated	
			at 20°C Ω/km	at 90°C Ω/km	at 20°C Ω/km	at 90°C Ω/km	
	Class 5 and Class 6 mm	at 20°C Ω/km	at 90°C Ω/km	at 20°C Ω/km	at 90°C Ω/km		
0.5	0.21	0.16	1.1	39.0	49.7	40.1	51.1
0.75	0.21	0.16	1.3	26.0	33.2	26.7	34.0
1.0	0.21	0.16	1.5	19.5	24.9	20.0	25.5
1.5	0.26	0.16	1.8	13.3	17.0	13.7	17.5
2.5	0.26	0.16	2.6	7.98	10.17	8.21	10.47
4	0.31	0.16	3.2	4.95	6.31	5.09	6.49
6	0.31	0.21	3.9	3.30	4.21	3.39	4.32
10	0.41	0.21	5.1	1.91	2.44	1.95	2.49
16	0.41	0.21	6.3	1.21	1.54	1.24	1.58
25	0.41	0.21	7.8	0.780	0.995	0.795	1.014
35	0.41	0.21	9.2	0.554	0.706	0.565	0.720
50	0.41	0.31	11.0	0.386	0.492	0.393	0.501
70	0.51	0.31	13.1	0.272	0.347	0.277	0.353
95	0.51	0.31	15.1	0.206	0.263	0.210	0.268
120	0.51	0.31	17.0	0.161	0.205	0.164	0.209
150	0.51	0.31	19.0	0.129	0.164	0.132	0.168
185	0.51	0.41	21.0	0.106	0.1352	0.108	0.138
240	0.51	0.41	24.0	0.0801	0.1021	0.0817	0.104
300	0.51	0.41	27.0	0.0641	0.0817	0.0654	0.083
400	0.51	-	31.0	0.0486	0.0620	0.0495	0.063
500	0.61	-	35.0	0.0384	0.0490	0.0391	0.050
630	0.61	-	39.0	0.0287	0.0366	0.0292	0.037

2. Wire gauge conversion table

U.S. standard		IEC and BS
AWG/MCM	Equivalent cross-section area mm ²	Nearest available cross-section area mm ²
20 AWG	0.519	1.5 or 0.75
18	0.823	1.0
16	1.31	1.5
14	2.08	2.5
12	3.31	4
10	5.26	6
8	8.37	10
6	13.30	16
4	21.15	25
2	33.62	35
1	42.41	50
1/0	53.49	50
2/0	67.23	70
3/0	85.01	95
4/0	107.2	120
250 MCM	126.7	120 or 150
300	152.0	150
350	177.3	185
400	202.7	185
450	228.0	240
500	253.4	240 or 300
550	278.7	300
600	304.0	300
650	329.4	300 or 400
700	354.7	400
750	380.0	400
800	405.4	400
850	430.7	400
900	456.0	400 or 500
950	481.4	500
1,000	506.7	500
1,250	633.4	630

High Voltage Flame Retardant Cable

High Voltage Flame & Fire Resistant Cable

Low Voltage Flame Retardant Cable

Low Voltage Flame & Fire Resistant Cable

Technical Information

3. Current ratings

- (1) Current ratings in accordance with IEC 60092-352 & IEC 61892-4 based on ambient air temperature of 45 °C and a conductor temperature of the maximum rated temperature of the 90°C insulation.

Nominal cross sectional area mm ²	Current carrying capacity		
	Single core	2 core	3 & 4 core
	A	A	A
1.5	23	20	16
2.5	30	26	21
4	40	34	28
6	52	44	36
10	72	61	50
16	96	82	67
25	127	108	89
35	157	133	110
50	196	167	137
70	242	206	169
95	293	249	205
120	339	288	237
150	389	331	272
185	444	377	311
240	522	444	365
300	601	511	421
400*	719	611	503
500*	703	703	579
630*	812	812	669

*IEC 61892-4

- (2) For more than 4-cores, the current ratings are given by the following formula;

$$I_N = \frac{I_1}{\sqrt[3]{N}}$$

I_1 = Current rating for 1-core

N = Number of cores

No. of cores	1.0 mm ²	1.5 mm ²	2.5 mm ²
5	9	13	17
7	8	12	15
10	7	10	13
12	7	10	13
14	7	9	12
16	6	9	11
19	6	8	11
24	6	7	10
30	5	7	9
33	5	7	9
37	5	6	9

- (3) The tabled current ratings must be adjusted for ambient air temperature other than 45 °C as follows;

Correction Factor for Various Ambient Air Temperatures

Ambient Temperature	35°C	40°C	45°C	50°C	55°C	60°C	65°C	70°C	75°C	80°C	85°C
Multiply Factor	1.10	1.05	1.00	0.94	0.88	0.82	0.74	0.67	0.58	0.47	-

4. Short circuit current ratings

- (1) The following short current ratings are for cables normally operating at a maximum conductor temperature of 90°C
- (2) The theoretical temperature that arises in the conductor during a short circuit, which is used as a basis of the calculation, is 250°C in accordance with IEC 60724.
- (3) EPR and XLPE insulation are capable of withstanding of short term temperature up to 250°C
- (4) The short circuit current ratings for copper conductors given in the table are values for one second for other duration the current may be calculated from the following formula;

$$I_t = \frac{I_1}{\sqrt{t}}$$

I_t = short circuit current for t second(kA)

I_1 = short circuit current for one second(kA)

t = short circuit duration(second)

Nominal cross section area mm ²	Short circuit current 1 second (kA)	Nominal cross section area mm ²	Short circuit current 1 second (kA)
1.5	0.21	70	10.02
2.5	0.36	95	13.59
4	0.57	120	17.17
6	0.86	150	21.46
10	1.43	185	26.47
16	2.29	240	34.34
25	3.58	300	42.93
35	5.01	400	57.23
50	7.15	500	71.54
-	-	630	90.14

- (5) The duration of the short circuit based on these assumptions should be between 0.2 sec .and 5 sec.

5. Reactance

- (1) The reactance of a cable operating in an A.C. system depends on many factors, including, in particular, the axial spacing between conductors and the proximity and magnetic properties of adjacent steelwork. The former is known for multicore cable, but may vary for single core cables depending upon the spacing between them and their disposition when installed.
- (2) Reactance of cables in certain dispositions remote from steelwork are calculable and are shown. The values specified in cable construction details are for cables with circular conductors. The value for a sector-shaped conductor should be taken as 90% of the calculated value.
- (3) Inductance for 2-, 3- and 4- core cables is given by the formula;

$$L = 0.2 \times \left[\ell n \left(\frac{2S}{d} \right) + 0.25 \right] \times 10^{-6}$$

L = inductance in H/m and phase

S = axial space between conductors in mm

d = conductor diameter in mm

- (4) Reactance for 2-, 3- and 4-core cables is given by the formula;

$$X = 2 \times f \times \pi \times L \times \ell$$

X = reactance in Ω per phase

f = frequency in Hz

L = inductance in H/m and phase

ℓ = conductor length in meter

6. Impedance

Impedance for 2,3-and 4-core cables is given by the formula ;

$$Z = \sqrt{(R^2 + X^2)}$$

Z =impedance in Ω per phase

R =resistance at operating temperature in Ω per phase

X =reactance on Ω per phase

7. Electrical circuit formulas

For determining amperes, horsepower, kilowatts and kilovolt-amperes

Desired data	Alternating Current			Direct Current
	Single-Phase	Two-Phase, Four-Wire	Three-Phase	
Amperes when kVA is known	$\frac{kVA \times 1000}{E}$	$\frac{kVA \times 1000}{2 \times E}$	$\frac{kVA \times 1000}{1.732 \times E}$	$\frac{kVA \times 1000}{E}$
Amperes when kW is known	$\frac{kW \times 1000}{E \times pf}$	$\frac{kW \times 1000}{2 \times E \times pf}$	$\frac{kW \times 1000}{1.732 \times E \times pf}$	$\frac{kW \times 1000}{E}$
Amperes when HP is known	$\frac{HP \times 746}{E \times \%Eff \times pf}$	$\frac{HP \times 746}{2 \times E \times \%Eff \times pf}$	$\frac{HP \times 746}{1.732 \times E \times \%Eff \times pf}$	$\frac{HP \times 746}{E \times \%Eff}$
Kilovolt-Amperes	$\frac{I \times E}{1000}$	$\frac{2 \times I \times E}{1000}$	$\frac{1.732 \times I \times E}{1000}$	$\frac{I \times E}{1000}$
Kilowatts	$\frac{I \times E \times pf}{1000}$	$\frac{2 \times I \times E \times pf}{1000}$	$\frac{1.732 \times I \times E \times pf}{1000}$	$\frac{I \times E}{1000}$
Horsepower	$\frac{I \times E \times \%Eff \times pf}{746}$	$\frac{2 \times I \times E \times \%Eff \times pf}{746}$	$\frac{1.732 \times I \times E \times \%Eff \times pf}{746}$	$\frac{I \times E \times \%Eff}{746}$

Where, E =volts between conductors

I =line current amperes

%Eff =percent efficiency of motor in decimal

pf =power factor($\cos \theta$) in decimal

kVA=kilovolt-amperes

kW =kilowatts

HP =horsepower

Note) In two-phase, three-wire balanced circuits, the current in the common conductor is 1.414 times of formulas of two-phase, four-wire in either of the other conductors.

Material Properties

1. Insulating materials

■ EPDM or EPR

EPDM is a hydrocarbon rubber that combines electrical performance suitable for fire resistance cables with mechanical toughness and resistance to ozone, UV light and heat, and meets the requirements of IEC 60092-360.

This material is intended to be used for the flexible cables in low and medium voltage range, and increasing use as a blend component with EVA as a sheath material for halogen-free cables with good fire protection behavior and low smoke generation.

The maximum allowable operating temperature of the EPR insulated conductor is 90°C in normal condition and 250°C in short-circuit condition.

■ XLPE

XLPE, Cross-linked Polyethylene, has excellent mechanical, chemical and electrical characteristics and meets the requirements of IEC 60092-360.

This material provides very low dielectric losses and low water absorption, thus, intended to be used for power, coaxial, instrumentation, telecommunication cables have very good transmission of electric energy and information.

The maximum allowable operating temperature of the XLPE insulated conductor is 90°C in normal condition and 250°C in short-circuit condition.

2. Sheathing materials

■ EMA or EVA

EMA, ethylene methyl acrylic, and EVA, ethylene vinyl acetate, are both multi-functional elastomers, which resist the combined deteriorating influences of heat, oil and water in accordance with IEC 60092-360 type SHF2.

This material can be compounded to produce high quality cable sheathing with low smoke, low toxicity and flame retardance with no halogen acid gas emission.

■ CSP

CSP, chlorosulphonated polyethylene, is the most useful balance of properties for cable sheath which has excellent mechanical properties such as high tensile strength, abrasion and flex-fatigue resistance, extremely good flame and oil resistance, weather resistance, ozone, oxygen and oxidizing chemicals resistance in accordance with IEC 60092-360 type SH.

■ POLYOLEFIN

Polyolefin is the thermoplastic halogen-free compound having an excellent mechanical and chemical properties, and meets the requirements of IEC 60092-360 type SHF1.

If oil resistance is required for a halogen-free compound, SHF2 compound recommended.

Fire performance of sheathed cables with polyolefin meets the requirements of IEC 60332-3 category A and IEC 60331 for fire resisting cable.

High Voltage Flame Retardant Cable

High Voltage Flame & Fire Resistant Cable

Low Voltage Flame Retardant Cable

Low Voltage Flame & Fire Resistant Cable

Technical Information

Test Methods

IEC 60331-21/-31(-1, -2, -3)

Fire Resisting Test for Electric Cables

- **Specimens**

A specimen of the completed cable 1,200 or 1700 mm long shall have 100 mm of sheath or outer coverings removed from each end.

- **Test Conditions**

- (1) The specimen shall be held horizontally by means of suitable clamps at each end of the sheath or protected portion.
- (2) The transformer shall be connected to the specimen through a 3A fuse in each phase and a 5A fuse shall be inserted in the neutral circuit which shall be earthed.
- (3) Adjacent conductors shall be connected to the different phases.
- (4) In case of -3, specimen shall be drawn into the appropriate metal enclosure.

- **Ignition Source**

- (1) The source of ignition shall be a 610 mm long tube type burner which produces a line of closely spaced flames.
- (2) The flame temperature shall maintain 750°C - 830°C during the test.

- **Shock-producing device**

- (1) Mild steel bar (25.0 ± 1) mm in diameter and (600 ± 5) mm long.
- (2) Drop under its own weight from of (60 ± 5, - 0) to the horizontal to strike the upper steel support of the wall.

- **Test Procedure**

- (1) The electrical supply shall be switched on and the voltage adjusted to that of the rated voltage of the specimen and this shall be applied continuously during the test.
- (2) The gas flame and test voltage shall be applied continuously for a period of 30 - 120 minutes.
- (3) In case of -21, Not less than 15 minute hours after flame has been extinguished, the specimen shall again be energized as described above.
- (4) Shock apply alter 5 min ± 10 s from activation and subsequently at 5 min ± 10s interval.

- **Requirement**

No failure of any of the 2A fuses occurs, when the withstand voltage is applied exceeding the rated voltage.

Test Methods

IEC 60331-1, -2, -3 & -21

Guide of Shipboard & Offshore cable Fire performance in IEC

Mechanical shock

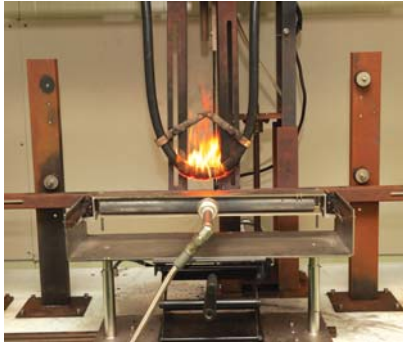

IEC 60331-1

without board panel
Cable Dia.20mm ↑



IEC 60331-2

with board panel
Cable Dia.20mm ↓

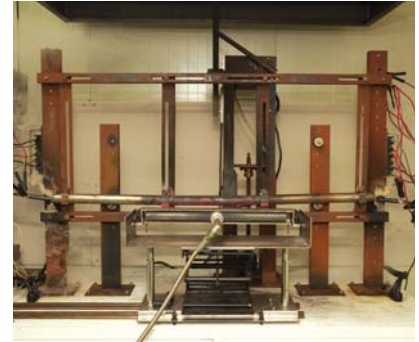

IEC 60331-3

Metal enclosure size
Multi core: 20mm(Cable Dia.20mm ↓)
40mm(11~23mm)
Single core: 20mm(Cable Dia.6.2mm ↓)
40mm(6.2~13.5mm)

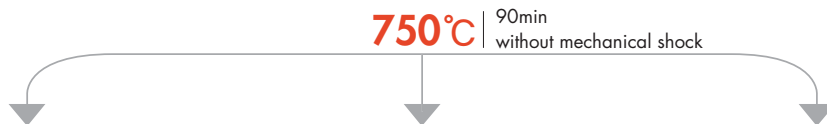
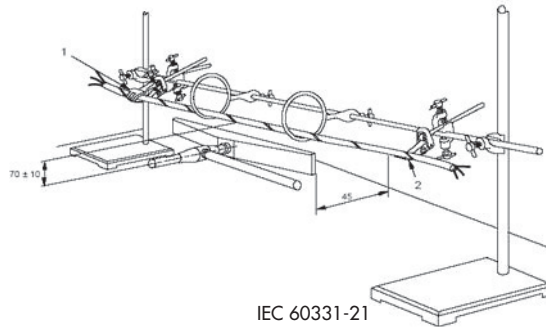
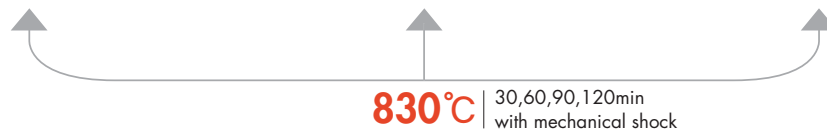

IEC 60331-21

Cables of rated up to and including 0.6/1kV

IEC 60331-23

Electric data cables

IEC 60331-25

Optical Fibre cables

High Voltage Flame
Retardant Cable

High Voltage Flame
& Fire Resistant Cable

Low Voltage Flame
Retardant Cable

Low Voltage Flame
& Fire Resistant Cable

Technical Information

IEC 60332-1

Flame Retardant Test for Single Vertical Insulated Wire or Cable

• Specimens

A specimen shall be a piece of the finished wire or cable 600 ± 25 mm long.

• Test Conditions

- (1) The specimen shall be kept at a temperature of $23 \pm 5^\circ\text{C}$ for minimum 16 hours at a relative humidity of $50 \pm 20\%$ before testing.
- (2) The specimen shall be fixed at two positions and aligned vertically within a 3-side metallic screen $1,200 \pm 25$ mm high, 300 ± 25 mm wide and 450 ± 25 mm deep with open front and closed top and bottom.
- (3) Distance between the top clamp and the bottom clamp is 550 ± 25 mm.
- (4) Distance between the bottom of specimen and the base of the screen is approximately 50 mm.

• Ignition Source

- (1) When propane gas is used, the bunsen burner shall be adjusted to give a flame approximately 175 mm long with an inner blue cone approximately 55 mm long.
- (2) When natural gas is used, the bunsen burner shall be adjusted to give a flame approximately 125 mm long with an inner blue cone approximately 40 mm long.

• Test Procedure

- (1) The axis angle between the burner tube and the specimen is 45° .
- (2) The continuous period of time corresponding to the diameter as following table ;

Overall Diameter of test specimen (mm)	Time for flame application (second)
O.D. ≤ 25	60
$25 < \text{O.D.} \leq 50$	120
$50 < \text{O.D.} \leq 75$	240
O.D. > 75	480

• Requirement

After all burning has ceased, the surface of the specimen shall be wiped clean and (1) the charred or affected portion shall not have reached within 50 mm of the lower edge of the top clamp, and (2) maximum length of downward charred surface shall not exceed 540 mm from the lower edge of the top clamp.

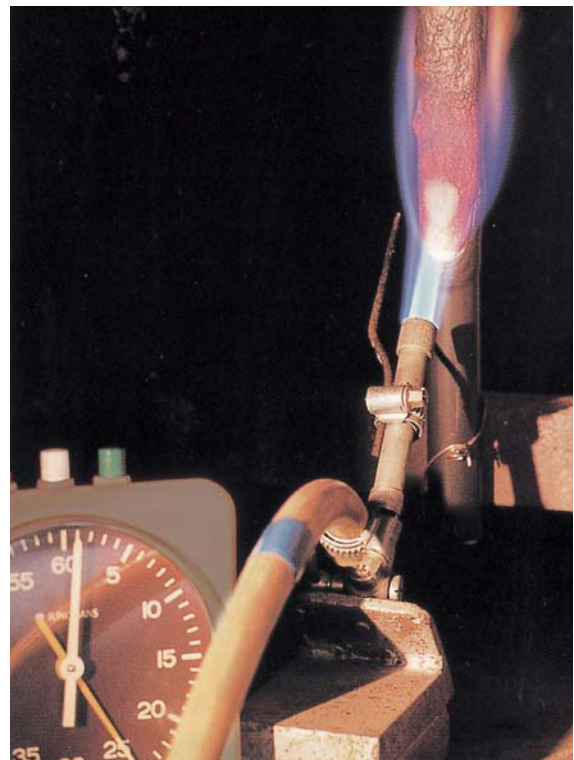

IEC 60332-3

Flame Retardant Test for Bunched Wires or Cables

• Specimens, Category & Designation

The specimens shall be a number of finished wire or cable in minimum 3,500 mm long, and the total number of 3.5 m test pieces in the test sample should be in accordance with one of the three categories as follows;

Category and Designation		AF / R	A		B		C		
Range of conductor cross-sections(mm ²)		> 35	≤ 35	> 35	≤ 35	> 35	≤ 35	> 35	
Non-metallic volume per metre of specimens(l)		7.0	7.0	7.0	7.0	3.5	3.5	1.5	1.5
Number of layer	For the standard ladder(300 mm)	2	≥ 1	1	-	≥ 1	1	≥ 1	1
	For the wide ladder(600 mm)	-	-	-	1	-	-	-	-
Positioning of the test pieces		spaced	touching	spaced		touching	spaced	touching	spaced
Flame application time(minutes)		40	40	40	40	40	40	20	20
Number of burners		1	1	1	2	1	1	1	1

• Test Conditions

- (1) The vertical test chamber shall have a width of 1.0 m, a depth of 2.0 m and a height of 4.0 m, and the floor of the chamber should be raised above ground level, and air being admitted at the base of the test chamber through an aperture of 800 mm × 400 mm situated 150mm from the front wall of the test chamber.
- (2) The ladder shall be have a height of 3.5 m, 9 rungs, and two types such as standard ladder of 500 mm width and wide ladder of 800 mm width.

• Ignition Source

- (1) The ignition source shall be of ribbon-type propane gas burner, flow meters, venturi mixer and whose flame-producing surface consist of a flat metal 341 mm long, 30 mm wide.
- (2) The air input rate should be 76.7 l /min, and the propane flow rate should be 13.3 l /min at one atmosphere and 20°C to provide a nominal 73.7×10^6 J/h(70,000Btu/h) to each burner.
- (3) The burner shall be arranged horizontally at a distance 75 mm from the front surface of the specimen and 600 mm above the floor of the test chamber.
- (4) The point of application of the burner flame shall lie in the center between two cross-bars on the ladder and at least 500 mm above the lower end of the specimen.

• Test Procedure

- (1) Determine the total volume per metre of non-metallic material of one test piece and the number of specimens to be mounted.
- (2) After mounted, the flame shall be applied for a period of specified flame application times.

• Requirement

After burning has ceased, the charred portion shall not have reached a height exceeding 2.5 m above the bottom edge of the burner, neither at the front nor the rear of ladder.

Simulation for IEC 60332-3 A/F Flame Retardant Test



Start



After 15 min.



After 30 min.

Finish



After 40 min.



Flame travel very little and die out immediately after fire is extinguished.

Simulation for Ordinary Cables

Flame are propagate to the top of the tray within 5 minutes.



IEEE 383

Vertical Tray Flame Test for Bunched Wires or Cables

• Specimens

The specimens shall be a number of finished cable in 8 feet(2.43 m) long.

• Test Conditions

- (1) The test should be conducted in a naturally ventilated room or enclosure free from excessive drafts and spurious air currents.
- (2) The tray shall be have a vertical, metal, ladder type 3 inch deep, 12 inch wide and 8 feet long.
- (3) The ribbon gas burner shall be mounted horizontally such that the flame impinges on the specimen midway between the tray rungs, and so that the burner face is 3 inch behind and approx. 2 feet above the bottom of the vertical tray.

• Ignition Source

- (1) The ignition source shall be of American Gas Furnace Co 10 inch, 11~55 drilling ribbon type with an air-gas venturi mixer.
- (2) The flame temperature should be approx. 815°C when measured by a thermocouple located in the flame close to about $\frac{1}{8}$ inch, but not touching the surface of the test specimens.
- (3) The flame length shall be approximately 15 inch when measured along its path.

• Test Procedure

- (1) Determine the number of specimens to be arranged in a single layer filling at least the center six inch portion of the tray with a separation of approx. $\frac{1}{2}$ the cable diameter between each cable.
- (2) After mounted, the flame shall be applied continuously 20 minutes.

• Requirement

After burning has ceased, the flame should be self-extinguished, and the charred portion shall not have reached the total height of the tray above the flame source.

Comparison Table IEEE 383 & IEC 60332-3

	IEEE 383	IEC 60332-3
Number of specimen	$N \geq (152.4 + 0.5D) / (1.5D)$ (N is integer, D is dia. in mm)	Category A : $N \geq 7.0$ liter / (Volume/m of one cable) Category B : $N \geq 3.5$ liter / (Volume/m of one cable) Category C : $N \geq 1.5$ liter / (Volume/m of one cable)
Length of specimen	8 feet(2.43m)	3.5 m
Ignition source	Ribbon burner	Ribbon burner
Test chamber	Not Specified	H : 4 m, W : 1 m, D : 2 m
Burning times	20 minutes	Category A & B ; 40 minutes Category C ; 20 minutes
Requirement	Not reach the top of the specimen	Not reach above 2.5 m of the specimen

IEC 60754-2

Degree of Acidity Gases Evolved(pH & Conductivity)

• Specimens

The specimen shall be of compound for insulation and jacket in weight of $1,000 \pm 5$ mg.

• Test Conditions

- (1) The combustion boat (L : 76 mm, W : 15 mm, D : 10 mm) with the specimen shall be placed in the combustion tube(L : 700 mm, Inside dia : 40 mm).
- (2) The combustion tube shall be placed in the tube furnace with thermocouple.
- (3) Two wash bottles having a containing at least 220ml of 0.1M sodium hydroxide shall be connected to the combustion tube.

• Test Procedure

- (1) The temperature at the position of the boat shall be not less than 935°C and the temperature at position 300 mm from the boat in direction of the air flow shall be not less than 900°C for 30 minutes.
- (2) The air flow shall be adjusted by means of needle valve at $0.0155 \times D^2 \ell / h \pm 10\%$ (D : tube inner dia. in mm) and is kept constant during the test.
- (3) The pH value and conductivity shall be determined at the end of the test.

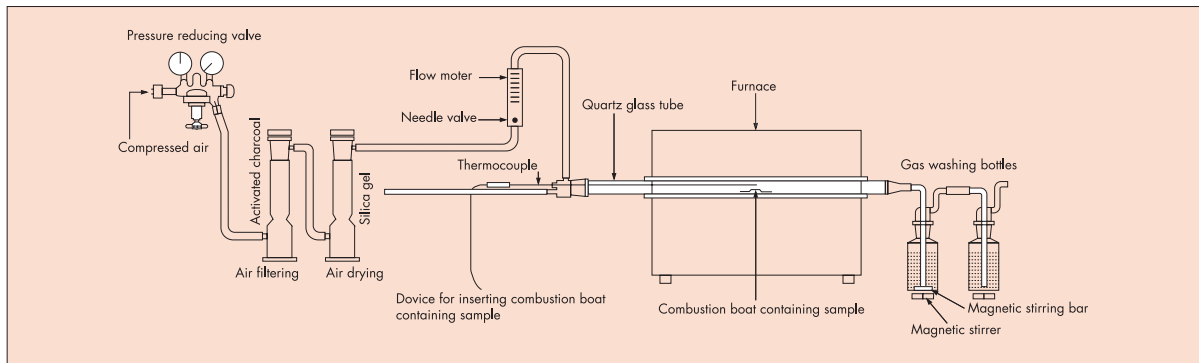

• Determination of pH value and conductivity

The weighted value of pH and conductivity are calculated as follows;

$$pH = \log_{10} \left[\frac{\sum i w_i}{\sum i (w_i / 10^x)} \right], \quad \text{Conductivity} = \frac{\sum i c \times w_i}{\sum i w_i}$$

Where, x is the pH value of each non-metallic material i.

c is conductivity of each non-metallic material i.

w_i is the weight of each metallic material i per unit length of cable.

• Requirements

- (1) The weighted pH value should not be less than 4.3, when related to 1ℓ of water.
- (2) The weighted value of conductivity should not exceed $10 \mu\text{S}/\text{mm}$.



ASTM D 2863

Oxygen Index Test

• Specimens

The specimen shall be compound taken from cable in length of 70~150 mm, width of 6.5 ± 0.5 mm, thickness 3.0 ± 0.5 mm.

• Test Conditions

(1) The column shall be of a heat-resistant glass tube(H :450 mm, Inside dia:75 mm) having the supplier of oxygen and nitrogen with flow measurement and control devices.

(2) The specimen holder shall hold the specimen vertically in the center of test column.

• Ignition Source

(1) The ignited shall be a tube with a small orifice(1~3 mm in diameter) having a gas flame.

• Test Procedure

(1) The oxygen gas shall flow in the column at the rate of 4 ± 1 cm/sec. at 0°C temperature and pressure 101.3 kPa until the suitable concentration of it.

(2) The specimen shall be ignited and if it burns for at least 3 minutes or length of flame is more than 50 mm, the concentration of oxygen shall be reduced.

(3) The concentration of oxygen when the burning is extinguished shall be checked.

• Calculation of Result

The oxygen Index(O. I) shall be obtained by the formula;

$$O. I (\%) = \frac{O_2}{O_2 + N_2} \times 100$$

Where, O_2 = Volumetric flow of oxygen, cm^3/s

N_2 = Volumetric flow of nitrogen, cm^3/s

Comparison chart for Oxygen Index

Material		Oxygen Index(Minimum)						
		24	26	28	30	32	34	36
Insulating	PVC							
	LS-PVC							
	EPR							
	XLPE							
	SR							
	Polyolefin							
Sheathing	PVC							
	LS-PVC							
	PCP							
	CPE							
	CSP							
	XLPO							
	HFC(EVA)							



NES 713

Toxicity Index Test

• Specimens

The specimen shall be compound for insulation and jacket in weight of 1.0 gram to 2.0 gram.

• Test Condition

- (1) Non-combustible specimen holder shall be located in the chamber of an air tight enclosure of at least 0.7 cubic meter volume.
- (2) The specimen holder shall be at over the burner in the center of the chamber.

• Ignition Source

- (1) A burner of internal barrel diameter 9.5 ± 0.5 mm and jet size 0.3 ± 0.1 mm shall be used.
- (2) The burner when lit shall be capable of being extinguished from outside the test chamber.
- (3) The burner fuel may be natural gas or any hydrocarbon gas as convenient.

• Test Procedure

- (1) The specimen holder with specimen of known mass shall be adjusted the height and position so that the bottom edge is 45 ± 2 mm from the burner.
- (2) The burner shall be ignited.
- (3) After completely burned, the specimen shall be analyzed with calorimetric gas reaction tubes.

• Calculation of Result

The toxicity index are derived from the calculated quantity of each gas that would be produced when 100g of the material is burnt in air in a volume of 1 cubic meter and the resulting concentration expressed as a factor of the concentration fatal to man at a 30 minute exposure time as follows;

$$\text{Combustion product } C_{\theta} = \frac{C \times 100}{m} \times V \text{ (ppm)}$$

Where, C_{θ} = Combustion products diffused in air(ppm/m³)

C = Concentration of gas in test chamber(ppm)

m = Fire test mass(g)

V = Volume of test chamber(m³)

C_i = Concentration of the gas considered fatal to man for a 30 minute exposure time(ppm)

$$\text{Toxicity Index} = \Sigma \left(\frac{C_{\theta 1}}{C_{f1}} + \frac{C_{\theta 2}}{C_{f2}} + \dots + \frac{C_{\theta n}}{C_{fn}} \right)$$

Comparison table for Toxicity Gas Generation

Kinds of Toxicity Gas	Fatal value C ppm/m ³	Toxicity Gas Generation(ppm/m ³)				
		PVC	XLPE	PCP	CSP	HFC
Carbon dioxide CO ₂	100,000	46,300	125,400	57,200	39,500	43,500
Carbon monoxide CO	4,000	5,525	1,971	4,300	3,640	1,405
Hydrogen sulphide H ₂ S	750	0	0	0	0	0
Ammonia NH ₃	750	0	0	0	0	0
Formaldehyde HCHO	500	0	0	0	0	0
Hydrogen chloride HCl	500	6,173	0	3,086	4,124	0
Acrylonitrile CH ₂ CHCN	400	0	0	0	0	0
Sulphur dioxide SO ₂	400	324	1.8	152	640	0
Nitrogen oxides NO+NO ₂	250	1.5	3.6	1.7	2.3	1.4
Hydrogen cyanide HCN	150	0	0	0	0	0
Hydrogen bromide HBr	150	0	0	0	0	0
Hydrogen fluoride HF	100	0	0	0	0	0



NES 715

Temperature Index Test

• Specimens

The specimen shall be compound taken from cable in length of 70~150 mm, width of 6.5 ± 0.5 mm, thickness 3.0 ± 0.5 mm.

• Test Conditions

- (1) The column shall be of a heat-resistant glass tube(H : 450 mm, Inside dia. : 75 mm) having the supplier of oxygen and nitrogen with flow measurement and control devices.
- (2) The specimen holder shall hold the specimen vertically in the center of test column.

• Ignition Source

- (1) The ignited shall be a tube with a small orifice(1~3 mm in diameter) having a gas flame.



• Test Procedure

- (1) The inside temperature of test column shall be adjusted to desired temperature and the inside column shall be maintained in a gas stream of 21% oxygen.
- (2) The specimen shall be attached specimen holder and ignited with ignited.
- (3) If the specimen will continue to burn for 3 minutes or for a 50 mm distance, retest shall be carried out with new specimen and reduced temperature.
- (4) If the specimen will be extinguished immediately, retest shall be carried out with new specimen and raised temperature.

• Result

The Temperature Index is the maximum temperature at which the specimen will not continue to burn for 3 minutes or for a 50 mm distance in a gas stream of 21% oxygen.

Comparison chart for Temperature Index

Material		Temperature Index(Minimum)								
		150	175	200	225	250	275	300	325	350
Insulating	PVC		█							
	LS-PVC		█							
	EPR			█						
	XLPE		█							
	SR									█
	Polyolefin					█				
Sheathing	PVC		█							
	LS-PVC			█						
	PCP				█					
	CPE				█					
	CSP					█				
	XLPO						█			
	HFC(EVA)								█	

ASTM E 662 Smoke density Test

• Specimens

The specimen shall be the sheet of 3 inch by 3 inch (76.2 mm × 76.2 mm) or a number of insulation in length of 3 inch.

• Test Conditions

- (1) The test apparatus shall consist of test chamber, radiant heat furnace, specimen holder, photo metric system and recorder.
- (2) The furnace control system shall maintain the required irradiance level, under steady-state conditions with the chamber door closed, of $2.50 \pm 0.05 \text{ W/cm}^2$ for 20 minutes.
- (3) The test specimens are exposed to the two test conditions within a closed chamber as follows;
 - A) Non-flaming condition : An electrically heated radiant-energy source mount.
 - B) Flaming condition : A six-tube burner flame in addition to the specified irradiance level from the heating element constitutes the flame combustion exposure.

• Test Procedure

- (1) The specimen shall be attached to the specimen holder and placed in the test chamber.
- (2) The photo-metric system and recorder shall be started and at that time ignite the radiant heat furnace.
- (3) After exposure of 20 minutes or until minimum light transmittance level have been reached over exposure of 20 minutes, the radiant heat furnace shall be extinguished and the gas in the chamber shall be exhausted until maximum transmittance is reached.

• Calculation of Result

Calculate the maximum specific optical density (D_m) with a light transmittance corresponding to the minimum level reached during the test as follows;

$$D_m = \frac{V}{A \cdot L} \cdot \left[\log_{10} \left(\frac{100}{T} \right) \right]$$

Where;

V = Volume of the closed chamber, ft³(or m³)

A = Exposed area of the specimen, ft²(or m²)

L = Length of the light path through the smoke, ft(or m)

T = Percent light transmittance as read from the light-sensing instrument.

Comparison chart for Smoke Density

Material	Smoke Density							
	100	200	300	400	600	800	900	1000
PVC								■
LS-PVC			■					
PCP						■	■	
CPE							■	
CSP			■					
XLPO	■							
HFC(EVA)	■							



High Voltage Flame
Retardant Cable

High Voltage Flame
& Fire Resistant Cable

Low Voltage Flame
Retardant Cable

Low Voltage Flame
& Fire Resistant Cable

Technical Information

IEC 61034-2

Smoke Density Test of Electric Cables Burning

• Specimens

- (1) The specimen shall consist of one or more samples of cable 1.00 ± 0.05 m long which shall be carefully straightened and then conditioned for at least 16 hours at $23 \pm 5^\circ\text{C}$.
- (2) The selection of number of test pieces shall be as following table;

Overall Diameter of the cable(D) mm	Number of test pieces	
	Cables	Bundles
D>40	1	-
20<D≤40	2	-
10<D≤20	3	-
5<D≤10	N ₁	-
2<D≤5	-	N ₂

Notes; 1. $N_1 = \text{integer}(45 \div D)$ cables
2. $N_2 = \text{integer}(45 \div 3D)$ bundles
3. The value of N_1 and N_2 shall be rounded downward to the integer to give the number of cables or bundles.
4. Each bundle shall consist of seven cables twisted together with a lay between 20D and 30D and bound with two turns of approximately 0.5 mm diameter wire in the center and at every 100 mm each side from the center.

- (3) The test pieces shall remain in situ during the test as follows:
 - cables shall be bound together at the ends, and at 300 mm from each end, at which place they shall be clamped to the support by means of wire binders.
 - bundles shall be tensioned at one or both ends by means of an appropriate device, e.g. a spring or weight.
- NOTE; It is recommended that small cables and flexible cables should be tensioned.

• Test Apparatus

- (1) Test enclosure ; a cubic enclosure with inside dimensions of $3,000 \pm 30$ mm and one side shall have a door with a glass inspection window.
- (2) Photometric system ; the light source and the receiver shall be placed externally in the center of both windows in the two opposite walls of the cube without making physical contact.
- (3) Standard fire source ; $1.00 \pm 0.01 \text{ l}$ of alcohol having no effect on the smoke emission of any cable under test.

• Test Procedure

- (1) Before each test, clean the windows of the photometric system to regain 100% light transmission after stabilization of the voltage.
- (2) The test samples supported above the tray, start the air circulation and ignite the alcohol and that the door is closed.
- (3) The test is considered as ended when there is no decrease in light transmittance for 5 minutes after the fire source has extinguished or when the test duration reaches 40 minutes.



27 m³ cube smoke chamber

• Requirement

The minimum light transmittance shall be not less than 60%.

CSA C 22.2 No. 38

Cold Impact & Cold Bending Test for Wires or Cables

	Cold Impact Test	Cold Bending Test
Specimen	The specimen shall be ten straight lengths of 5 inch(12.7 cm).	The specimen shall be straight.
Test Condition	<p>(1) The refrigerator shall be with a rigid post having a solid base and maintain the specific temperature.</p> <p>(2) The impact component shall be used a steel ball of 3 pounds in weight.</p>	<p>(1) The refrigerator shall maintain the specific temperature.</p> <p>(2) The mandrel to wind the specimen shall be specified in proportion to the diameter of specimen.</p>
Test Procedure	<p>(1) The specimen shall be placed in the refrigerator in temperature -40°C for 4 hours</p> <p>(2) The specimen shall be subjected to the impact component falling freely from a height of 36 inch(914 cm).</p>	<p>(1) The specimen and the subjected mandrel shall be placed in refrigerator in a subjected temperature for 4 hours.</p> <p>(2) The specimen, while still in the refrigerator, shall be rewound in subjected mandrel in the opposite direction between 30 and 60 seconds at subjected temperature.</p>
Requirement	Not exceeding two among the ten specimens shall crack or rupture.	Neither the insulation nor jacket shall crack or rupture when wound or around the mandrel.



High Voltage Flame Retardant Cable

High Voltage Flame & Fire Resistant Cable

Low Voltage Flame Retardant Cable

Low Voltage Flame & Fire Resistant Cable

Technical Information

NEK 606

Mud Resistance Test

- **Specimens**

The specimen shall be sheath compound taken from cable.

- **Test Conditions**

The test chamber shall maintain to temperature in 70°C, with include mud oil.

- **Test Procedure**

(1) Before the immersion, the specimens shall be measured by suitable apparatus to obtain properties at room temperature.

(2) The specimens shall be immersed in mud chamber at temperature 70°C.

(3) After 56 days of immersion, the specimens should be cleaned and tested for changes of elongation at break, tensile strength, volume swelling, weight increase.

- **Requirements**

The sheathing compound shall be fully satisfied with the following properties;

	Calcium Bromide	EDC 95-11 base oil
Elongation at break	+/- 25%	+/- 30%
Tensile strength	+/- 25%	+/- 30%
Volume swelling	+/- 20%	+/- 25%
Weight change	+/- 15%	+/- 25%

Drum Capacity

Drum dimensions and weights											
KUKDONG Drum No.	Outer drum dia. (D) mm	Flange dia. (F) mm	Barrel dia. (B) mm	Inner width (Wi) mm	Outer width (Wo) mm	Centre hole dia. (H) mm	Free space (S) mm	Thick. of lagging (T) mm	CBM m ³	Weight without lagging kg	Weight with lagging kg
3-5	700	640	300	328	400	80	30	30	0.20	19	33
4-7	850	790	350	328	400	80	30	30	0.29	25	43
6-2	910	850	450	400	500	80	50	30	0.41	44	68
7-3	1,040	970	500	500	600	80	50	35	0.65	60	98
7-4	1,070	1,000	500	500	600	80	50	35	0.69	61	101
9-1	1,170	1,100	600	630	750	110	65	35	1.03	95	150
9-3	1,270	1,200	600	630	750	110	65	35	1.21	108	168
9-7	1,370	1,300	700	630	750	110	65	35	1.41	129	193
11-1	1,470	1,400	800	750	900	110	85	35	1.94	184	267
11-3	1,570	1,500	800	750	900	110	85	35	2.22	202	292
11-5	1,670	1,600	800	750	900	110	85	35	2.51	221	317
13-5	1,790	1,700	1,000	750	900	110	85	45	2.88	264	395
13-7	1,890	1,800	1,000	750	900	110	85	45	3.21	287	427
14-5	1,990	1,900	1,200	870	1,050	110	100	45	4.16	410	580
14-6	2,090	2,000	1,200	870	1,050	110	100	45	4.59	423	599
16-2	2,190	2,100	1,400	1,020	1,200	110	100	45	5.76	518	735
16-3	2,290	2,200	1,400	1,020	1,200	110	100	45	6.29	556	780
16-4	2,390	2,300	1,400	1,020	1,200	110	100	45	6.85	590	825
17-4	2,490	2,400	1,600	1,020	1,200	110	100	45	7.44	662	901
17-5	2,590	2,500	1,600	1,020	1,200	110	100	45	8.05	740	997
17-6	2,690	2,600	1,600	1,020	1,200	110	100	45	8.68	740	1,008

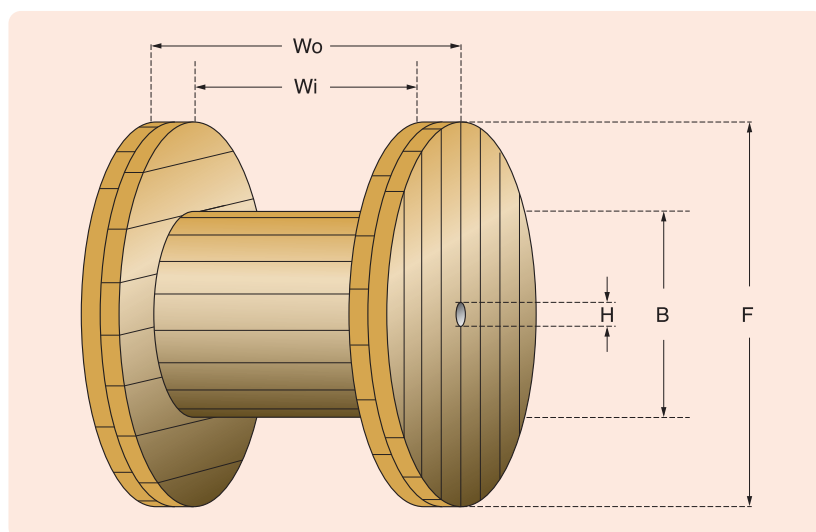

Drum code	3-5	4-7	6-2	7-3	7-4	9-1	9-3	9-7	11-1	11-3	11-5	13-5	13-7	14-5	14-6	16-2	16-3	16-4	17-4	17-5	17-6	Drum code
Cable Dia. (mm)	Reel Capacity in Meters (Free Space 90% Application)																				Cable Dia. (mm)	
6	2,005																					6
7	1,457																					7
8	1,105	1,826	2,044																			8
9	884	1,437	1,553																			9
10	703	1,191	1,247																			10
11	551	981	1,072	1,809	2,055																	11
12	469	801	848	1,581	1,694																	12
13	399	647	725	1,282	1,490	1,863																13
14	337	563	619	1,118	1,214	1,625																14
15	282	488	526	972	1,061	1,414	1,938															15
16	270	424	501	842	925	1,224	1,713	1,918														16
17	224	363	424	727	805	1,057	1,516	1,697	2,078													17
18	215	350	355	694	694	1,012	1,340	1,500	1,823													18
19		299	340	598	668	869	1,176	1,317	1,594	2,057												19
20		254	282	510	575	743	1,031	1,156	1,390	1,827												20
21		245	271	490	554	715	994	1,112	1,336	1,614												21
22			220	414	473	604	865	969	1,155	1,553	1,838											22
23			212	399	457	582	747	838	1,116	1,371	1,782											23
24			205	333	386	563	724	811	959	1,324	1,587	1,571										24
25			200	323	375	472	704	787	929	1,162	1,411	1,381										25
26			159	313	313	457	604	677	791	1,010	1,368	1,202	1,612									26
27			154	257	304	443	587	657	766	979	1,208	1,163	1,426	1,409								27
28			149	249	295	366	500	560	743	951	1,174	1,128	1,384	1,363								28
29				242	287	355	486	544	626	822	1,033	978	1,220	1,326								29
30				235	235	346	474	530	610	802	1,010	953	1,190	1,138								30
31				189	230	278	397	446	592	778	878	924	1,037	1,104	1,399							31
32					270	386	433	492	667	859	794	1,013	1,073	1,361								32
33					263	377	422	479	651	839	774	989	911	1,184								33
34					258	369	413	467	635	725	754	857	887	1,154	1,195							34
35					252	305	343	456	537	710	639	838	866	1,127	1,163							35
36					202	255	285	379	458	541	545	641	738	864	992							36
37					197	249	278	370	447	529	532	625	722	846	967							37
38						271	291	438	519	521	613	587	824	792	1,105							38
39						266	284	429	509	510	600	576	690	773	923							39
40						260	278	347	498	414	587	562	674	757	905							40
41							203	272	339	411	404	487	551	661	738	883						41
42							200	267	333	404	396	478	539	647	722	864	1,012					42

Drum code	3-5	4-7	6-2	7-3	7-4	9-1	9-3	9-7	11-1	11-3	11-5	13-5	13-7	14-5	14-6	16-2	16-3	16-4	17-4	17-5	17-6	Drum code
Cable Dia. (mm)	Reel Capacity in Meters (Free Space 90% Application)																					Cable Dia. (mm)
43								195	261	327	397	389	469	528	634	709	849	995				43
44									256	321	390	381	460	417	620	562	830	973				44
45									192	315	383	373	451	410	507	551	680	955	761			45
46									189	248	378	296	445	402	498	540	667	799	746			46
47									185	242	304	289	360	394	489	532	656	787	734			47
48									182	239	299	284	354	387	480	520	643	771	719	860		48
49									179	235	295	280	349	379	470	512	632	759	707	846		49
50									176	231	290	275	343	374	464	503	622	747	695	832		50
51													270	337	366	454	494	611	734	683	818	51
52													265	331	360	360	485	485	600	543	670	803
53													260	325	273	354	369	476	589	533	658	789
54													255	255	269	349	361	467	578	523	646	774
55													193	252	264	343	356	460	571	515	637	764
56													189	247	259	337	351	454	563	508	628	753
57													187	244	255	331	344	445	552	497	615	739
58													184	241	252	328	338	438	544	490	606	728
59													182	238	247	322	333	431	536	482	597	597
60													179	235	244	318	330	427	531	478	591	591
61													175	230	240	312	324	420	420	470	470	582
62													173	226	237	308	319	414	414	462	462	574
63															234	234	313	313	407	351	454	563
64															229	229	310	310	403	348	449	557
65															226	226	305	305	396	341	441	548
66															159	223	217	301	391	337	437	542
67															157	220	214	298	387	333	432	536
68															155	216	212	294	383	329	427	530
69															154	215	207	289	376	323	419	419
70															151	212	205	285	371	319	414	414
71															149	209	202	281	367	315	408	408
72															147	206	200	278	362	311	403	403
73															146	204	197	274	274	307	307	398
74															143	201	194	271	271	303	303	393
75															142	200	193	269	269	301	301	391
76																	190	266	266	297	297	386
77																	188	262	262	293	293	380
78																	185	185	258	207	288	375
79																	184	184	257	206	287	373
80																	181	181	253	203	282	368

Cable Scale

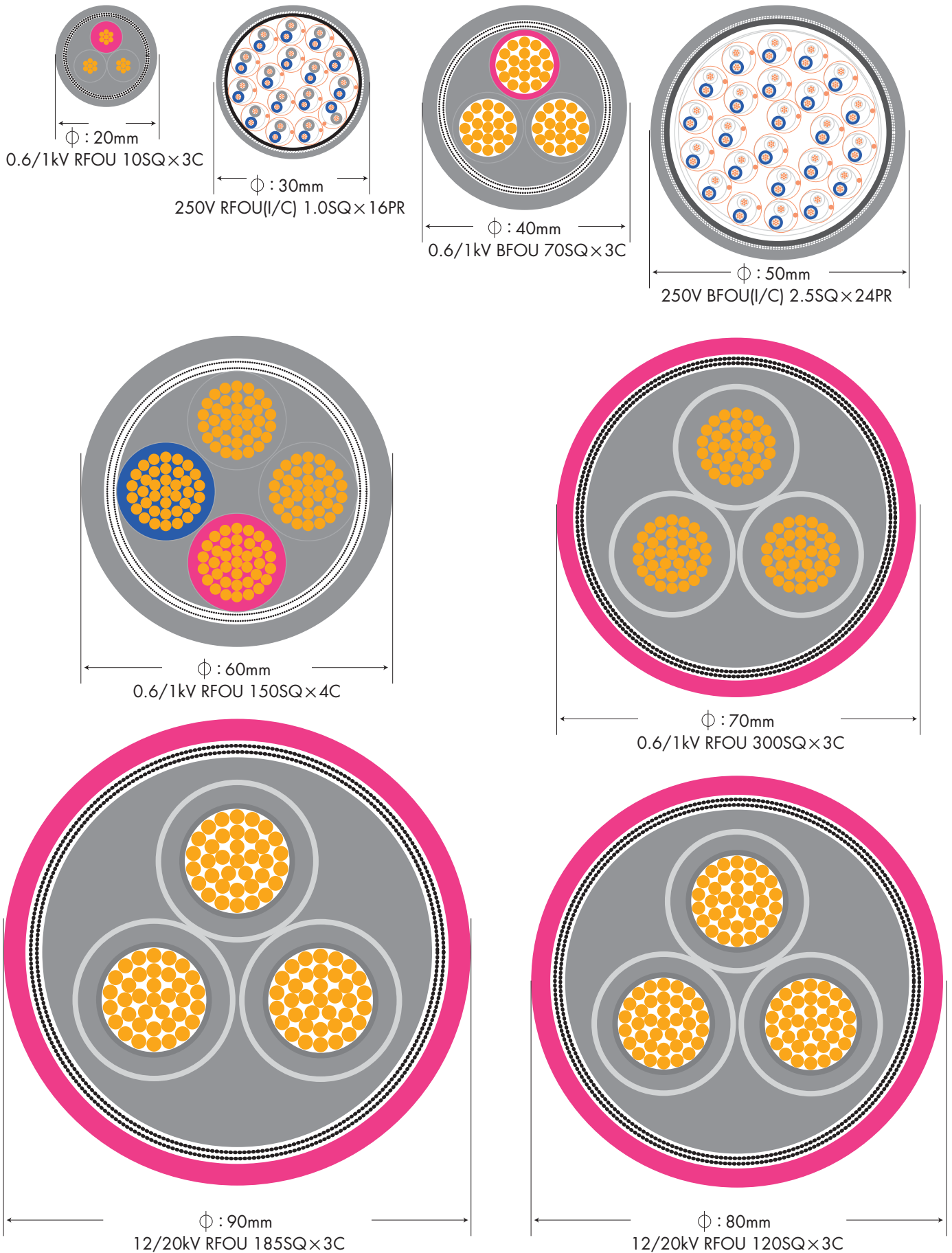

Nexans brings energy to life through an extensive range of cables and cabling solutions that deliver increased performance for our customers worldwide. Nexans' teams are committed to a partnership approach that supports customers in four main business areas: Power transmission and distribution (submarine and land), Energy resources (Oil & Gas, Mining and Renewables), Transportation (Road, Rail, Air, Sea) and Building (Commercial, Residential and Data Centers). Nexans' strategy is founded on continuous innovation in products, solutions and services, employee development, customer training and the introduction of safe, low-environmental-impact industrial processes. In 2013, Nexans became the first cable player to create a Foundation to introduce sustained initiatives for access to energy for disadvantaged communities worldwide. Nexans is an active member of Europacable, the European Association of Wire & Cable Manufacturers, and a signatory of the Europacable Industry Charter. The Charter expresses its members' commitment to the principles and objectives of developing ethical, sustainable and high-quality cables. Nexans, acting for the energy transition, has an industrial presence in 40 countries and commercial activities worldwide, employing close to 26,000 people and generating sales in 2015 of 6.2 billion euros. Nexans is listed on NYSE Euronext Paris, compartment A.

Kukdong, as an all-round cable maker, occupies the leading position in the world in the area of shipboard and offshore cables which require stringent quality features. It provided an international launching platform by its merger with the Nexans Group of France in 2003. The main products are shipboard, offshore and its manufacturing plant is located in Jincheon, Korea.

HEAD OFFICE & FACTORY

370-95, Yongjeong-Ri, Chopyong-Myon, Jincheon-Gun, ChungcheongbukK-Do, KOREA 365-850
TEL:+82-43-530-2068, FAX:+82-43-530-2144

SALES OFFICE

7F, I'Park Tower, #160, Samseong-Dong, Gangnam-Gu, Seoul, KOREA 135-881
TEL:+82-2-2140-3064, FAX:+82-2-2140-3098

BUSAN OFFICE

#1015 You One Golden Tower, 474-80, Bujeon-1 Dong, Busanjin-Gu, Buan, KOREA 614-031
TEL:+82-51-817-0295, FAX:+82-51-817-0297

www.cablekukdong.co.kr
www.nexans.co.kr